

LD303

smar

JUN/21
LD303
VERSION 3



OPERATION AND MAINTENANCE
INSTRUCTION / MANUAL

Profibus PA Pressure Transmitter

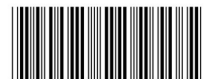
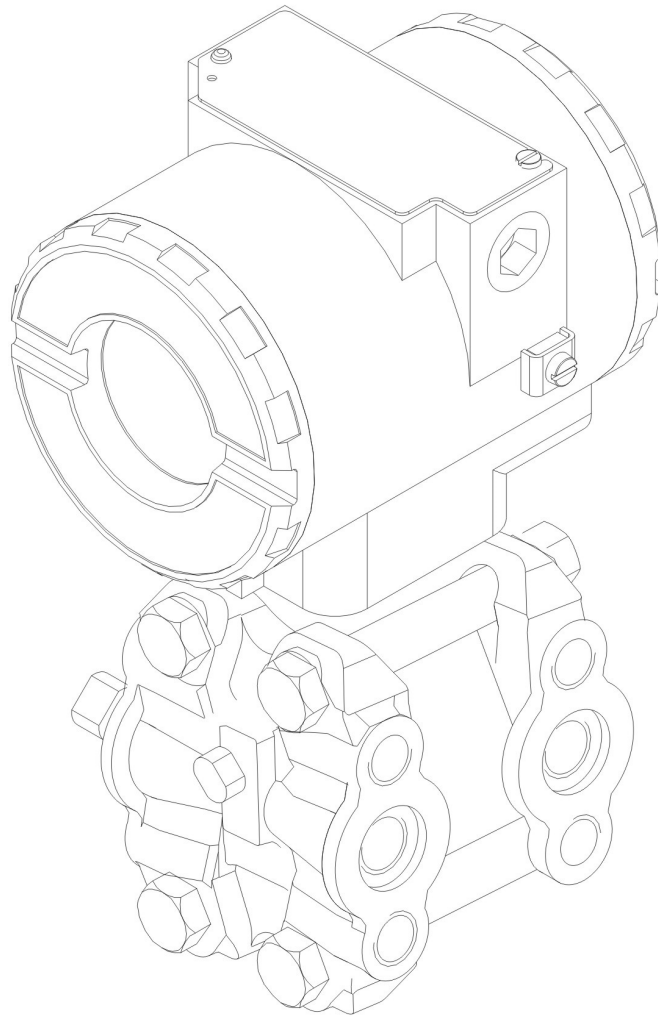

LD303ME

smar
NOVA SMAR S/A
www.smar.com.br

Specificatinos and information are subject to change without notice.
Up-to-date address information is available on our website.

[web: www.smar.com/contactus.asp](http://www.smar.com/contactus.asp)

INTRODUCTION

The **LD303** is from the first generation of Profibus-PA devices. It is a transmitter for differential, absolute and gauge pressure, level and flow measurements. It is based on a field-proven capacitive sensor that provides reliable operation and high performance. The digital technology used in the **LD303** enables the choice of several types of transfer functions, an easy interface between the field and the control room and several interesting features that considerably reduce the installation, operation and maintenance costs.

The **LD303** is part of Smar's complete 303 line of Profibus-PA devices.

Some of the advantages of bi-directional digital communications are known from existing smart transmitter protocols: Higher accuracy, multi-variable access, remote configuration and diagnostics, and multi-dropping of several devices on a single pair of wires.

The system controls variable sampling, algorithm execution and communication so as to optimize the usage of the network, not losing time. Thus, high closed loop performance is achieved.

Using Profibus technology, with its capability to interconnect several devices, very large control schemes can be constructed. In order to be user friendly the function block concept was introduced. The **LD303**, like the rest of the 303 family, has some Function Blocks built in, like Analog Input and Totalizer Block.

The need for implementation of Fieldbus in small as well as large systems was considered when developing the entire 303 line of Profibus-PA devices. They have common features and can be configured locally using a magnetic tool, eliminating the need for a configurator or console in many basic applications.

The **LD303** is available as a product on its own, but also replaces the circuit board for the LD301. They use the same sensor board. Refer to the maintenance section of this manual for instructions on upgrading. The **LD303** uses the same hardware and housing for the LD301. The **LD303** is part of SMAR's **Series 303** of Profibus-PA devices.

The **LD303**, like its predecessor LD301, has some built-in blocks, eliminating the need for a separate control device. The communication requirement is considerably reduced, and that means less dead-time and tighter control is achieved, not to mention the reduction in cost. They allow flexibility in control strategy implementation.

Get the best results of the LD303 by carefully reading these instructions.

WARNING

In case of using Simatic PDM as the configuration and parameterization tool, Smar recommends that the user does not apply the option "Download to Device". This function can improperly configure the field device. Smar recommends that user make the use of the option "Download to PG / PC" and then selecting the Device Menu, use the menus of the transducer, function and display blocks acting specifically, according to each menu and method for reading and writing.

NOTE

This Manual is compatible with version 3.XX, where 3 denotes software version and XX software release. The indication 3.XX means that this manual is compatible with any release of software version 3.

Waiver of responsibility

The contents of this manual abides by the hardware and software used on the current equipment version. Eventually there may occur divergencies between this manual and the equipment. The information from this document are periodically reviewed and the necessary or identified corrections will be included in the following editions. Suggestions for their improvement are welcome.

Warning

For more objectivity and clarity, this manual does not contain all the detailed information on the product and, in addition, it does not cover every possible mounting, operation or maintenance cases.

Before installing and utilizing the equipment, check if the model of the acquired equipment complies with the technical requirements for the application. This checking is the user's responsibility.

If the user needs more information, or on the event of specific problems not specified or treated in this manual, the information should be sought from Smar. Furthermore, the user recognizes that the contents of this manual by no means modify past or present agreements, confirmation or judicial relationship, in whole or in part.

All of Smar's obligation result from the purchasing agreement signed between the parties, which includes the complete and sole valid warranty term. Contractual clauses related to the warranty are not limited nor extended by virtue of the technical information contained in this manual.

Only qualified personnel are allowed to participate in the activities of mounting, electrical connection, startup and maintenance of the equipment. Qualified personnel are understood to be the persons familiar with the mounting, electrical connection, startup and operation of the equipment or other similar apparatus that are technically fit for their work. Smar provides specific training to instruct and qualify such professionals. However, each country must comply with the local safety procedures, legal provisions and regulations for the mounting and operation of electrical installations, as well as with the laws and regulations on classified areas, such as intrinsic safety, explosion proof, increased safety and instrumented safety systems, among others.

The user is responsible for the incorrect or inadequate handling of equipments run with pneumatic or hydraulic pressure or, still, subject to corrosive, aggressive or combustible products, since their utilization may cause severe bodily harm and/or material damages.

The field equipment referred to in this manual, when acquired for classified or hazardous areas, has its certification void when having its parts replaced or interchanged without functional and approval tests by Smar or any of Smar authorized dealers, which are the competent companies for certifying that the equipment in its entirety meets the applicable standards and regulations. The same is true when converting the equipment of a communication protocol to another. In this case, it is necessary sending the equipment to Smar or any of its authorized dealer. Moreover, the certificates are different and the user is responsible for their correct use.

Always respect the instructions provided in the Manual. Smar is not responsible for any losses and/or damages resulting from the inadequate use of its equipments. It is the user's responsibility to know and apply the safety practices in his country.

TABLE OF CONTENTS

SECTION 1 - INSTALLATION	1.1
GENERAL	1.1
HOUSING ROTATION	1.9
BUS TOPOLOGY AND NETWORK CONFIGURATION	1.11
WIRING	1.11
INTRINSIC SAFETY BARRIER	1.12
JUMPER CONFIGURATION	1.12
POWER SUPPLY	1.13
INSTALLATION IN HAZARDOUS AREAS	1.13
SECTION 2 - OPERATION	2.1
FUNCTIONAL DESCRIPTION - SENSOR	2.1
FUNCTIONAL DESCRIPTION – ELECTRONICS	2.2
DISPLAY	2.3
SECTION 3 - CONFIGURATION	3.1
TRANSDUCER BLOCK	3.1
TRANSDUCER BLOCK DIAGRAM	3.2
PRESSURE TRANSDUCER BLOCK PARAMETER DESCRIPTION	3.2
PRESSURE TRANSDUCER BLOCK PARAMETER ATTRIBUTES	3.6
LD303 - CYCLIC CONFIGURATION	3.8
HOW TO CONFIGURE THE TRANSDUCER BLOCK	3.9
TABLE HANDLING	3.11
HOW TO CONFIGURE THE ANALOG INPUT BLOCK	3.15
HOW TO CONFIGURE THE TOTALIZER BLOCK	3.19
LOWER AND UPPER TRIM	3.24
PRESSURE TRIM - LD303	3.24
VIA LOCAL ADJUSTMENT	3.26
CHARACTERIZATION TRIM	3.27
SENSOR INFORMATION	3.29
TEMPERATURE TRIM	3.29
SENSOR DATA READING	3.30
TRANSDUCER DISPLAY – CONFIGURATION	3.31
DISPLAY TRANSDUCER BLOCK	3.31
DEFINITION OF PARAMETERS AND VALUES	3.32
LOCAL ADJUSTMENT TREE - QUICK GUIDE	3.35
PROGRAMMING USING LOCAL ADJUSTMENT	3.36
J1 JUMPER CONNECTION	3.37
W1 JUMPER CONNECTION	3.37
SECTION 4 - MAINTENANCE PROCEDURES	4.1
GENERAL	4.1
DISASSEMBLY PROCEDURE	4.2
SENSOR CLEANING	4.2
ELECTRONIC CIRCUIT	4.3
REASSEMBLE PROCEDURE	4.3
SENSOR MOUNTING	4.3
ELECTRONIC CIRCUIT	4.4
INTERCHANGEABILITY	4.4
UPGRADING LD301 TO LD303	4.5
RETURNING MATERIALS	4.5
SMAR INSULATOR KIT	4.9
SMAR INSULATOR KIT MOUNTING	4.9
APPLICATION WITH HALAR	4.14
TECHNICAL SPECIFICATION	4.14
PERFORMANCE SPECIFICATION	4.14

TPE – TOTAL PROBABLE ERROR (SOFTWARE)	4.14
ORDERING CODE FOR THE SENSOR	4.16
SECTION 5 - TECHNICAL CHARACTERISTIC	5.1
Technical Characteristics of High Performance - CODE L1	5.5
Ordering Code.....	5.6
APPENDIX A - CERTIFICATIONS INFORMATION.....	A.1
APPENDIX B – SRF – SERVICE REQUEST FORM.....	B.1

Basic Installation Flowchart

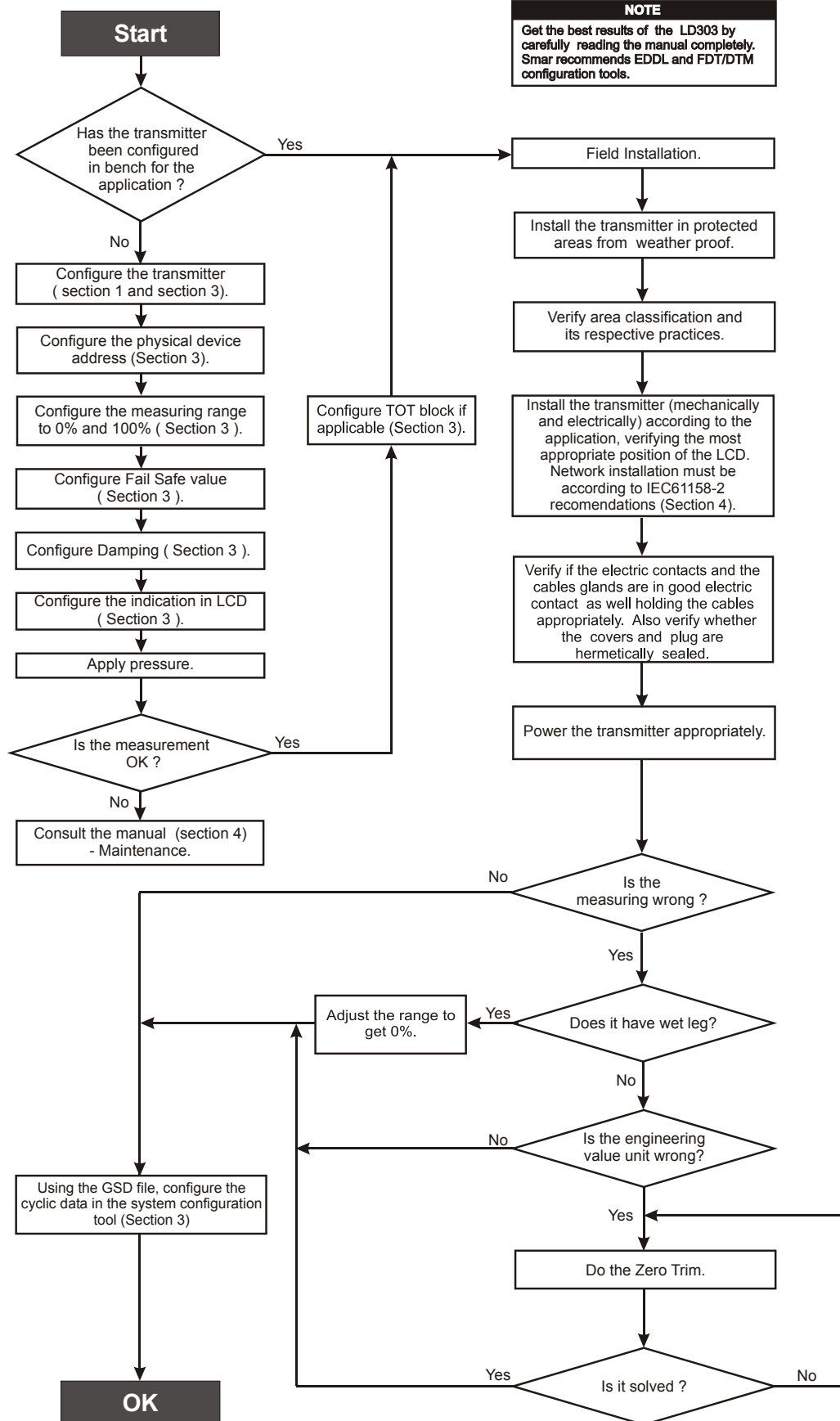

INSTALLATION

General

NOTE
The installation carried out in hazardous areas should follow the recommendations of the IEC60079-14 standard.

The overall accuracy of a flow, level, or pressure measurement depends on several variables. Although the transmitter has an outstanding performance, proper installation is essential to maximize its performance.

Among all factors, which may affect transmitter accuracy, environmental conditions are the most difficult to control. There are, however, ways of reducing the effects of temperature, humidity and vibration.

The **LD303** has a built-in temperature sensor to compensate for temperature variations. At the factory, each transmitter is submitted to a temperature cycle process, and the characteristics under different pressures and temperatures are recorded in the transmitter memory. At the field, this feature minimizes the temperature variation effect.

Locating the transmitter in areas protected from extreme environmental changes can minimize temperature fluctuation effects.

The transmitter should be installed in such a way as to avoid, as much as possible, direct exposure to the sun or any source of irradiated heat. Installation close to lines and vessels with high temperatures should also be avoided. Use longer sections of impulse piping between tap and transmitter whenever the process fluid is at high temperatures. Use of sunshades or heat shields to protect the transmitter from external heat sources should be considered.

Humidity is fatal for electronic circuits. In areas subjected to high relative humidity, the O-rings for the electronic housing covers must be correctly placed and the covers must be completely closed by tightening them by hand until the O-rings are compressed.

Do not use tools to close the covers. Removal of the electronics cover in the field should be reduced to the minimum necessary, as each time it is removed; the circuits are exposed to the humidity. The electronic circuit is protected by a humidity proof coating, but frequent exposure to humidity may affect the protection provided. It is also important to keep the covers tightened in place. Every time they are removed, the threads are exposed to corrosion, since painting cannot protect these parts. Code-approved sealing methods should be employed on conduit entering the transmitter. The unused outlet connection should be plugged accordingly.

Although the transmitter is virtually insensitive to vibration, installation close to pumps, turbines or other vibrating equipment should be avoided. Proper winterization (freeze protection) should be employed to prevent freezing within the measuring chamber, since this will result in an inoperative transmitter and could even damage the cell.

NOTE
When installing or storing the level transmitter, the diaphragm must be protected to avoid scratching-denting or perforation of its surface.

The transmitter has been designed to be both rugged and lightweight at the same time. This makes its mounting easier; mounting positions are shown in Figure 1.1.

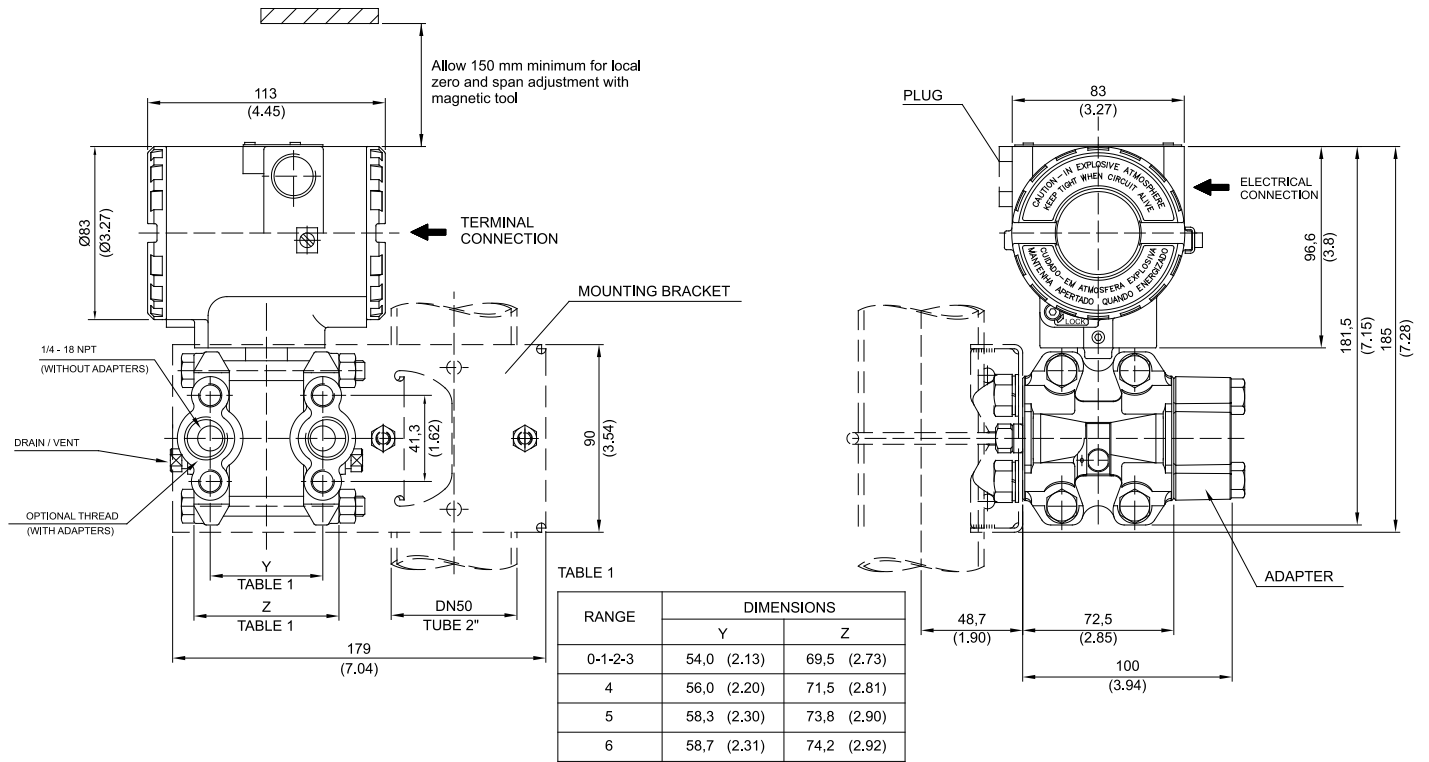
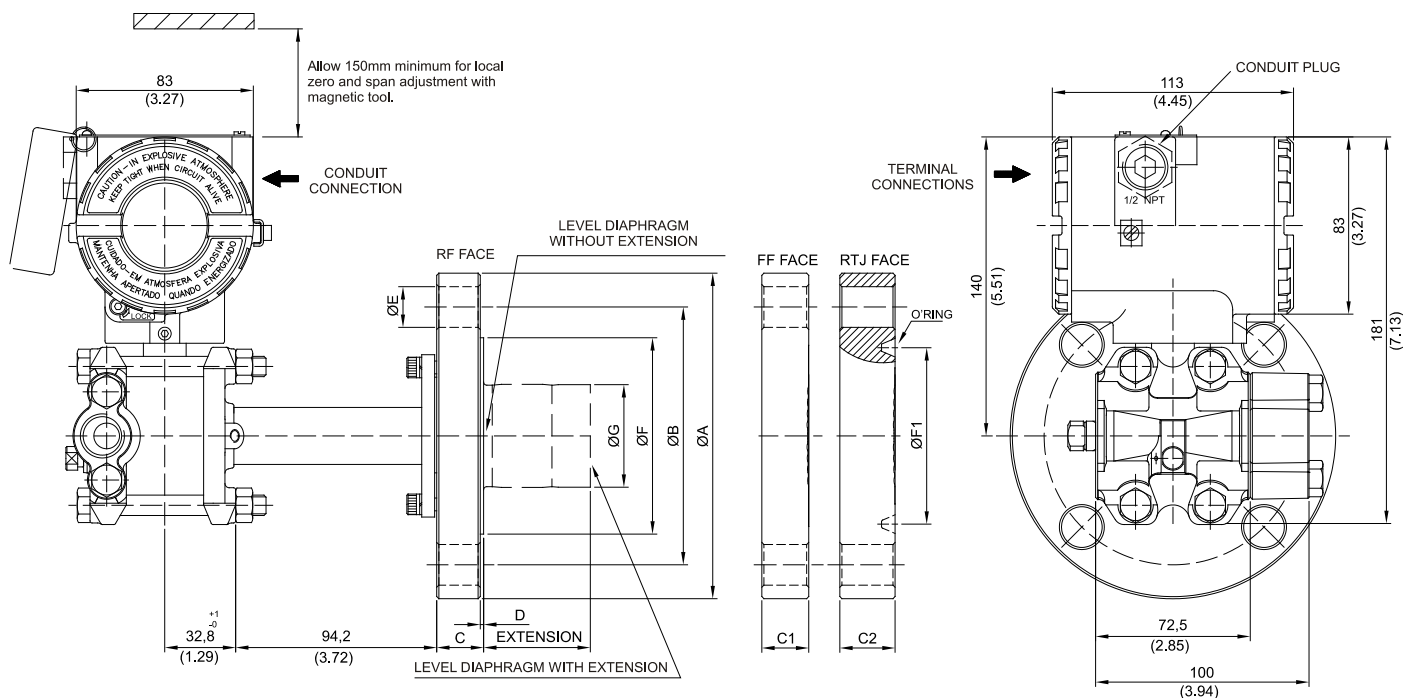

Figure 1.1 (a) – Dimensional Drawing and Mounting Position - Differential, Flow, Gage, Absolute and High Static Pressure Transmitters with Mounting Bracket



Notes:
 - Extension length (mm): 0, 50, 100, 150 or 200
 - Dimensions are mm (in)

ANSI-B 16.5 DIMENSIONS														
DN	CLASS	A	B	C (RF)	C1 (FF)	C2 (RTJ)	D (RF)	E	F (RF)	F1 (RTJ)	RTJ O'RING	G	HOLES	
1.1/2"	150	127 (5)	98.6 (3.88)	20 (0.78)	19 (0.75)	24.4 (0.96)	1.6 (0.06)	16 (0.63)	73.2 (2.88)	65.1 (2.56)	R19	40 (1.57)	4	
	300	155.4 (6.12)	114.3 (4.5)	21 (0.83)	21 (0.83)	27.4 (1.07)	1.6 (0.06)	22 (0.87)	73.2 (2.88)	68.3 (2.68)	R20	40 (1.57)	4	
	600	155.4 (6.12)	114.3 (4.5)	29.3 (1.15)	29.3 (1.15)	29.3 (1.15)	6.4 (0.25)	22 (0.87)	73.2 (2.88)	68.3 (2.68)	R20	40 (1.57)	4	
2"	150	152.4 (6)	120.7 (4.75)	22 (0.87)	20 (0.78)	25.9 (1.02)	1.6 (0.06)	19 (0.75)	91.9 (3.62)	82.6 (3.25)	R22	48 (1.89)	4	
	300	165.1 (6.5)	127 (5)	22.8 (0.9)	22.8 (0.89)	30.8 (1.21)	1.6 (0.06)	19 (0.75)	91.9 (3.62)	82.6 (3.25)	R23	48 (1.89)	8	
	600	165.1 (6.5)	127 (5)	32.3 (1.27)	32.3 (1.27)	32.3 (1.27)	6.4 (0.25)	19 (0.75)	91.9 (3.62)	82.6 (3.25)	R23	48 (1.89)	8	
3"	150	190.5 (7.5)	152.4 (6)	24.4 (0.96)	24.4 (0.96)	30.7 (1.21)	1.6 (0.06)	19 (0.75)	127 (5)	114.3 (4.50)	R29	73 (2.87)	4	
	300	209.5 (8.25)	168.1 (6.62)	29 (1.14)	29 (1.14)	36.9 (1.45)	1.6 (0.06)	22 (0.87)	127 (5)	123.8 (4.87)	R31	73 (2.87)	8	
	600	209.5 (8.25)	168.1 (6.62)	38.7 (1.52)	38.7 (1.52)	40.2 (1.58)	6.4 (0.25)	22 (0.87)	127 (5)	123.8 (4.87)	R31	73 (2.87)	8	
4"	150	228.6 (9)	190.5 (7.5)	24.4 (0.96)	24.4 (0.96)	30.7 (1.21)	1.6 (0.06)	19 (0.75)	158 (6.22)	149.2 (5.87)	R36	96 (3.78)	8	
	300	254 (10)	200 (7.87)	32.2 (1.27)	32.2 (1.27)	40.2 (1.58)	1.6 (0.06)	22 (0.87)	158 (6.22)	149.2 (5.87)	R37	96 (3.78)	8	
	600	273 (10.75)	215.9 (8.5)	45 (1.77)	45 (1.77)	46.5 (1.83)	6.4 (0.25)	25 (1)	158 (6.22)	149.2 (5.87)	R37	96 (3.78)	8	
EN 1092-1 DIMENSIONS														
DN	PN	A	B	C (RF)	C1 (FF)		D	E	F (RF)			G	HOLES	
DN40	10/40	150 (5.9)	110 (4.33)	20 (0.78)	20 (0.78)		3 (0.12)	18 (0.71)	88 (3.46)			40 (1.57)	4	
DN50	10/40	165 (6.5)	125 (4.92)	20 (0.78)	22 (0.86)		3 (0.12)	18 (0.71)	102 (4.01)			48 (1.89)	4	
DN80	10/40	200 (7.87)	160 (6.3)	24 (0.95)	24 (0.94)		3 (0.12)	18 (0.71)	138 (5.43)			73 (2.87)	8	
DN100	10/16	220 (8.67)	180 (7.08)	20 (0.78)			3 (0.12)	18 (0.71)	158 (6.22)			96 (3.78)	8	
	25/40	235 (9.25)	190 (7.5)	24 (0.95)			3 (0.12)	22 (0.87)	162 (6.38)			96 (3.78)	8	
JIS B 2202 DIMENSIONS														
DN	CLASS	A	B	C			D	E	F (RF)			G	HOLES	
40A	20K	140 (5.5)	105 (4.13)	26 (1.02)			2 (0.08)	19 (0.75)	81 (3.2)			40 (1.57)	4	
50A	10K	155 (6.1)	120 (4.72)	26 (1.02)			2 (0.08)	19 (0.75)	96 (3.78)			48 (1.89)	4	
	40K	165 (6.5)	130 (5.12)	26 (1.02)			2 (0.08)	19 (0.75)	105 (4.13)			48 (1.89)	8	
80A	10K	185 (7.28)	150 (5.9)	26 (1.02)			2 (0.08)	19 (0.75)	126 (4.96)			73 (2.87)	8	
	20K	200 (7.87)	160 (6.3)	26 (1.02)			2 (0.08)	19 (0.75)	132 (5.2)			73 (2.87)	8	
100A	10K	210 (8.27)	175 (6.89)	26 (1.02)			2 (0.08)	19 (0.75)	151 (5.95)			96 (3.78)	8	

Figure 1.1 (b) – Dimensional Drawing and Mounting Position - Flanged Pressure Transmitter with Integral Flange

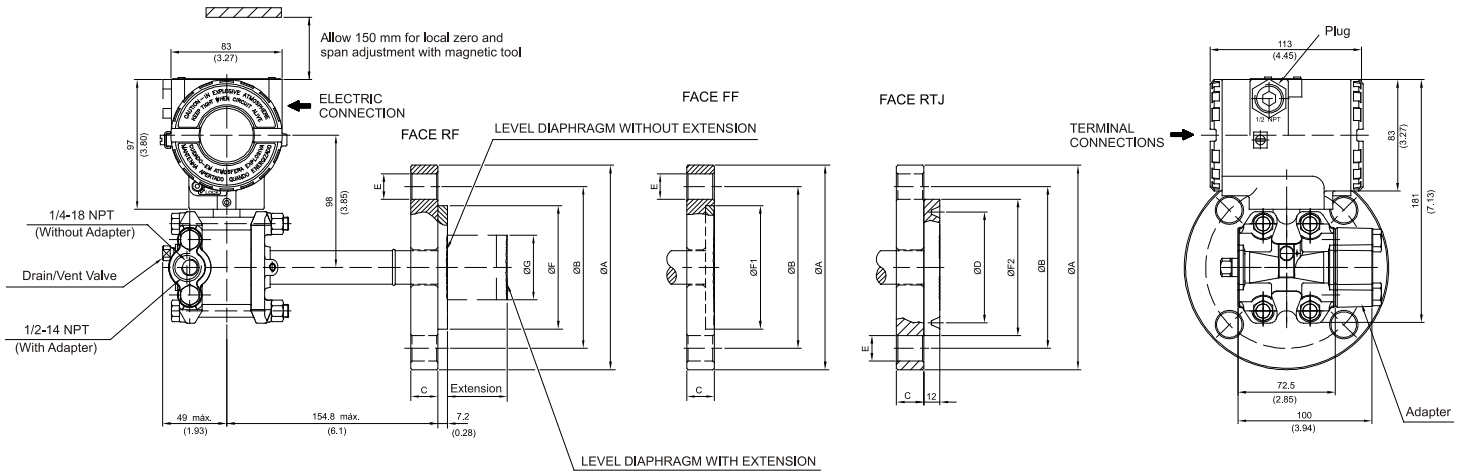

ANSI-B 16.5 DIMENSIONS											
DN	CLASS	A	B	C	D	E	F (RF)	F1 (FF)	F2 (RTJ)	G	HOLES
1"	150	108 (4.25)	79.4 (3.16)	14.3 (0.56)	-	16 (0.63)	50.8 (2)	50.8 (2)	-	-	4
	300/600	124 (4.88)	88.9 (3.5)	17.5 (0.69)	-	19 (0.75)	50.8 (2)	50.8 (2)	-	-	4
1 1/2"	150	127 (5)	98.4 (3.87)	17.5 (0.69)	-	16 (0.63)	73 (2.87)	73 (2.87)	-	40 (1.57)	4
	300/600	156 (6.14)	114.3 (4.5)	22.2 (0.87)	-	22 (0.87)	73 (2.87)	73 (2.87)	-	40 (1.57)	4
2"	150	152.4 (6)	120.7 (4.75)	17.5 (0.69)	82.6 (3.25)	19 (0.75)	92 (3.62)	92 (3.62)	101.6 (4.00)	48 (1.89)	4
	300	165.1 (6.5)	127 (5)	20.7 (0.8)	82.6 (3.25)	19 (0.75)	92 (3.62)	92 (3.62)	107.9 (4.25)	48 (1.89)	8
	600	165.1 (6.5)	127 (5)	25.4 (1)	82.6 (3.25)	19 (0.75)	92 (3.62)	92 (3.62)	107.9 (4.25)	48 (1.89)	8
3"	150	190.5 (7.5)	152.4 (6)	22.3 (0.87)	114.3 (4.50)	19 (0.75)	127 (5)	127 (5)	133.4 (5.25)	73 (2.87)	4
	300	209.5 (8.25)	168.1 (6.62)	27 (1.06)	123.8 (4.87)	22 (0.87)	127 (5)	127 (5)	146.1 (5.75)	73 (2.87)	8
	600	209.5 (8.25)	168.1 (6.62)	31.8 (1.25)	123.8 (4.87)	22 (0.87)	127 (5)	127 (5)	146.1 (5.75)	73 (2.87)	8
4"	150	228.6 (9)	190.5 (7.5)	22.3 (0.87)	149.2 (5.87)	19 (0.75)	158 (6.22)	158 (6.22)	171.5 (6.75)	89 (3.5)	8
	300	254 (10)	200 (7.87)	30.2 (1.18)	149.2 (5.87)	22 (0.87)	158 (6.22)	158 (6.22)	174.6 (6.87)	89 (3.5)	8
	600	273 (10.75)	215.9 (8.5)	38.1 (1.5)	149.2 (5.87)	25 (1)	158 (6.22)	158 (6.22)	174.6 (6.87)	89 (3.5)	8

EN 1092-1 / DIN2501 DIMENSIONS - RF/ FF								
DN	PN	A	B	C	E	F	G	HOLES
25	10/40	115 (4.53)	85 (3.35)	18 (0.71)	14 (0.55)	68 (2.68)	-	4
40	10/40	150 (5.91)	110 (4.33)	18 (0.71)	18 (0.71)	88 (3.46)	73 (2.87)	4
50	10/40	165 (6.50)	125 (4.92)	20 (0.78)	18 (0.71)	102 (4.01)	48 (1.89)	4
80	10/40	200 (7.87)	160 (6.30)	24 (0.95)	18 (0.71)	138 (5.43)	73 (2.87)	8
100	10/16	220 (8.67)	180 (7.08)	20 (0.78)	18 (0.71)	158 (6.22)	89 (3.5)	8
	25/40	235 (9.25)	190 (7.50)	24 (0.95)	22 (0.87)	162 (6.38)	89 (3.5)	8

NOTES:
 -EXTENSION LENGTH IN mm(in): 0, 50 (1.96), 100 (3.93), 150(5.9) or 200 (7.87)
 -DIMENSIONS IN mm(in)

Figure 1.1 (c) – Dimensional Drawing and Mounting Position - Flanged Pressure Transmitter with Slip-on Flange

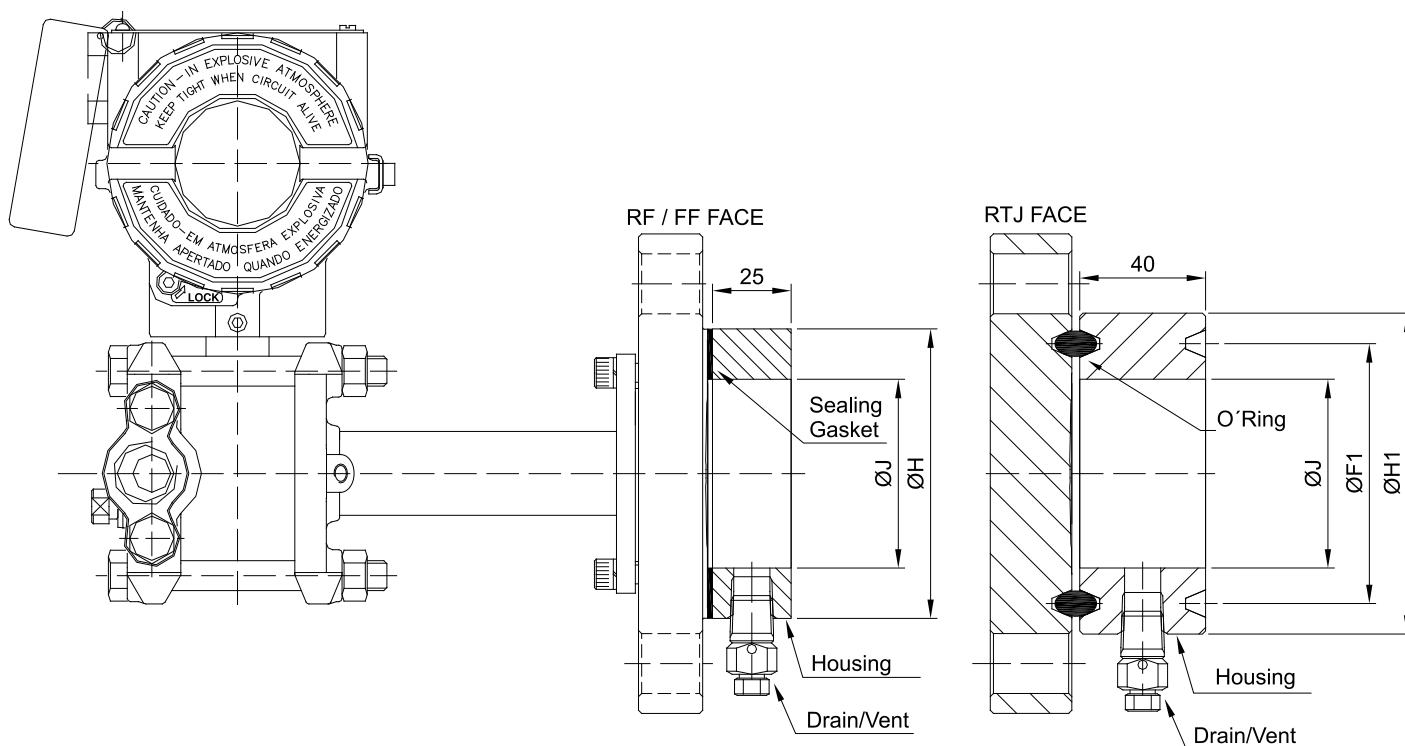

DIMENSIONS IN mm (")

ANSI-B 16.5 DIMENSIONS			
DN	CLASS	H	J
1.1/2"	ALL	73,2 (2,88)	48 (1,89)
2"		91,9 (3,62)	60 (2,36)
3"		127 (5,00)	89 (3,50)
4"		158 (6,22)	115 (4,53)
DIN EN1092-1/ DIN2501/2526 FORM D DIMENSIONS			
DN	PN	H	J
40	ALL	88 (3,46)	48 (1,89)
50		102 (4,02)	60 (2,36)
80		138 (5,43)	89 (3,50)
100		158 (6,22)	115 (4,53)
JIS B 2202 DIMENSIONS			
DN	CLASS	H	J
40A	20K	81 (3,19)	48 (1,89)
50A	10K	96 (3,78)	60 (1,36)
	40K	105 (4,13)	60 (1,36)
80A	10K	126 (4,96)	89 (3,50)
	20K	132 (5,20)	89 (3,50)
100A	10K	151 (5,94)	115 (4,53)

DIMENSIONS IN mm (")

ANSI-B 16.5 DIMENSIONS - RTJ FACE					
DN	CLASS	F1	O'RING	H1	J
1.1/2"	150	65,1 (2,56)	R19	82,5 (3,25)	48 (1,89)
	300	68,3 (2,69)	R20	90,5 (3,56)	48 (1,89)
	600	68,3 (2,69)	R20	90,5 (3,56)	48 (1,89)
	1500	68,3 (2,69)	R20	92 (3,62)	48 (1,89)
	2500	82,6 (3,25)	R23	114 (4,50)	48 (1,89)
2"	150	82,6 (3,25)	R22	102 (4,00)	60 (2,36)
	300	82,6 (3,25)	R23	108 (4,25)	60 (2,36)
	600	82,6 (3,25)	R23	108 (4,25)	60 (2,36)
	1500	95,3 (3,75)	R24	124 (4,88)	60 (2,36)
	2500	101,6 (4,00)	R26	133 (5,25)	60 (2,36)
3"	150	114,3 (4,50)	R29	133 (5,25)	89 (3,50)
	300	123,8 (4,87)	R31	146 (5,75)	89 (3,50)
	600	123,8 (4,87)	R31	146 (5,75)	89 (3,50)
4"	150	149,2 (5,87)	R36	171 (6,75)	115 (4,53)
	300	149,2 (5,87)	R37	175 (6,88)	115 (4,53)
	600	149,2 (5,87)	R37	175 (6,88)	115 (4,53)

Figure 1.1 (d) – Dimensional Drawing and Mounting Position - Flanged Pressure Transmitter with Housing

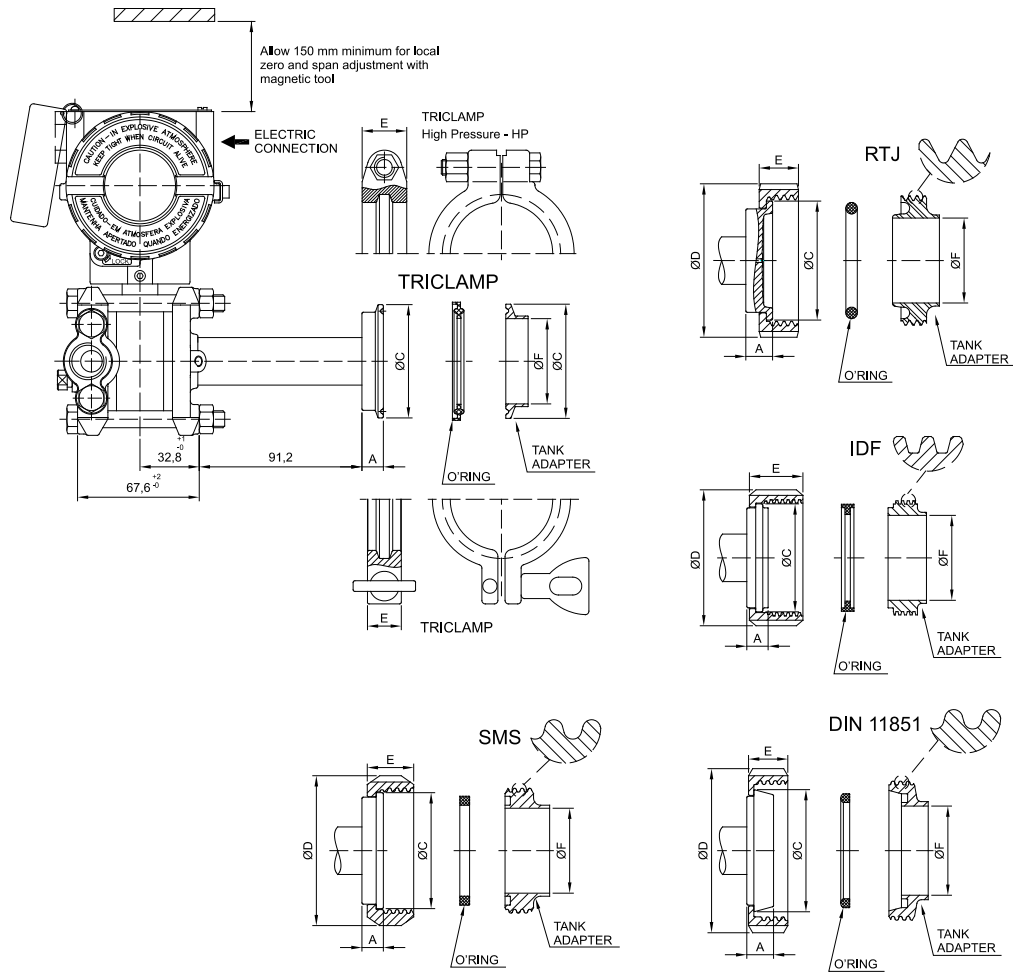

LD300S							
CONNECTION WITHOUT EXTENSION	Dimensions in mm (")						
	A	ØC	ØD	E	ØF	ØG	EXT.
Tri-Clamp DN50	8 (0.315)	63.5 (2.5)	76.5 (3.01)	18 (0.71)	47.5 (1.87)	--	---
Tri-Clamp - 1 1/2"	12 (0.47)	50 (1.96)	61 (2.4)	18 (0.71)	35 (1.38)	--	---
Tri-Clamp - 1 1/2" HP	12 (0.47)	50 (1.96)	66 (2.59)	25 (0.98)	35 (1.38)	--	---
Tri-Clamp - 2"	12 (0.47)	63.5 (2.5)	76.5 (3.01)	18 (0.71)	47.6 (1.87)	--	---
Tri-Clamp - 2" HP	12 (0.47)	63.5 (2.5)	81 (3.19)	25 (0.98)	47.6 (1.87)	--	---
Tri-Clamp - 3"	12 (0.47)	91 (3.58)	110 (4.33)	18 (0.71)	72 (2.83)	--	---
Tri-Clamp - 3" HP	12 (0.47)	91 (3.58)	115 (4.53)	25 (0.98)	72 (2.83)	--	---
Threaded DN40 - DIN 11851	13 (0.51)	56 (2.2)	78 (3.07)	21 (0.83)	38 (1.5)	--	---
Threaded DN50 - DIN 11851	15 (0.59)	68.5 (2.7)	92 (3.62)	22 (0.86)	50 (1.96)	--	---
Threaded DN80 - DIN 11851	16 (0.63)	100 (3.94)	127 (5)	29 (1.14)	81 (3.19)	--	---
Threaded SMS - 1 1/2"	12 (0.47)	55 (2.16)	74 (2.91)	25 (0.98)	35 (1.38)	--	---
Threaded SMS - 2"	12 (0.47)	65 (2.56)	84 (3.3)	26 (1.02)	48.6 (1.91)	--	---
Threaded SMS - 3"	12 (0.47)	93 (3.66)	113 (4.45)	32 (1.26)	73 (2.87)	--	---
Threaded RJT - 2"	15 (0.59)	66.7 (2.63)	86 (3.38)	22 (0.86)	47.6 (1.87)	--	---
Threaded RJT - 3"	15 (0.59)	92 (3.62)	112 (4.41)	22.2 (0.87)	73 (2.87)	--	---
Threaded IDF - 2"	12 (0.47)	60.5 (2.38)	76 (2.99)	30 (1.18)	47.6 (1.87)	--	---
Threaded IDF - 3"	12 (0.47)	87.5 (3.44)	101.6 (4)	30 (1.18)	73 (2.87)	--	---

Figure 1.1 (e) – Dimensional Drawing and Mounting Position - Sanitary Transmitter without Extension

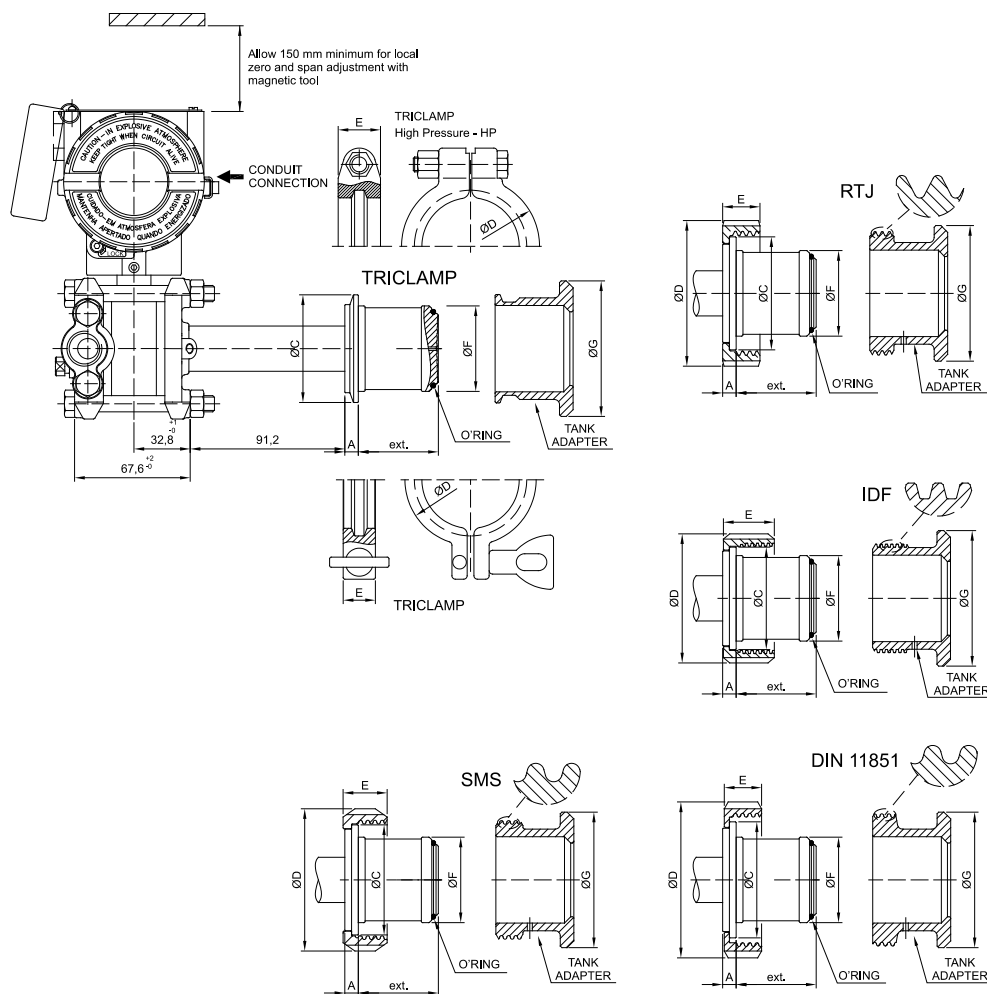

LD300S							
CONNECTION WITH EXTENSION	Dimensions in mm (")						
	A	ØC	ØD	E	ØF	ØG	EXT.
Tri-Clamp DN50	8 (0.315)	63.5 (2.5)	76.5 (3.01)	18 (0.71)	50.5 (1.99)	80 (3.15)	48 (1.89)
Tri-Clamp DN50 HP	8 (0.315)	63.5 (2.5)	81 (3.19)	25 (0.98)	50.5 (1.99)	80 (3.15)	48 (1.89)
Tri-Clamp - 2"	8 (0.315)	63.5 (2.5)	76.5 (3.01)	18 (0.71)	50.5 (1.99)	80 (3.15)	48 (1.89)
Tri-Clamp - 2" HP	8 (0.315)	63.5 (2.5)	81 (3.19)	25 (0.98)	50.5 (1.99)	80 (3.15)	48 (1.89)
Tri-Clamp - 3"	8 (0.315)	91 (3.58)	110 (4.33)	18 (0.71)	72.5 (2.85)	100 (3.94)	50 (1.96)
Tri-Clamp - 3" HP	8 (0.315)	91 (3.58)	115 (4.53)	25 (0.98)	72.5 (2.85)	100 (3.94)	50 (1.96)
Threaded DN25 - DIN 11851	6 (0.24)	47.5 (1.87)	63 (2.48)	21 (0.83)	43.2 (1.7)	80 (3.15)	26.3 (1.03)
Threaded DN40 - DIN 11851	8 (0.315)	56 (2.2)	78 (3.07)	21 (0.83)	50.5 (1.99)	80 (3.15)	48 (1.89)
Threaded DN50 - DIN 11851	8 (0.315)	68.5 (2.7)	92 (3.62)	22 (0.86)	50.5 (1.99)	80 (3.15)	48 (1.89)
Threaded DN80 - DIN 11851	8 (0.315)	100 (3.94)	127 (5)	29 (1.14)	72.5 (2.85)	100 (3.94)	50 (1.96)
Threaded SMS - 2"	8 (0.315)	65 (2.56)	84 (3.3)	26 (1.02)	50.5 (1.99)	80 (3.15)	48 (1.89)
Threaded SMS - 3"	8 (0.315)	93 (3.66)	113 (4.45)	32 (1.26)	72.5 (2.85)	100 (3.94)	50 (1.96)
Threaded RJT - 2"	8 (0.315)	66.7 (2.63)	86 (3.38)	22 (0.86)	50.5 (1.99)	80 (3.15)	48 (1.89)
Threaded RJT - 3"	8 (0.315)	92 (3.62)	112 (4.41)	22.2 (0.87)	72.5 (2.85)	100 (3.94)	50 (1.96)
Threaded IDF - 2"	8 (0.315)	60.5 (2.38)	76.2 (3)	30 (1.18)	50.5 (1.99)	80 (3.15)	48 (1.89)
Threaded IDF - 3"	8 (0.315)	87.5 (3.44)	101.6 (4)	30 (1.18)	72.5 (2.85)	100 (3.94)	50 (1.96)

Figure 1.1 (f) – Dimensional Drawing and Mounting Position - Sanitary Transmitter with Extension

Existing standards for the manifolds have also been taken into account, and standard designs fit perfectly to the transmitter flanges.

Should the process fluid contain solids in suspension, install valves or rod-out fittings at regular intervals to clean out the pipes.

The pipes should be internally cleaned by using steam or compressed air, or by draining the line with the process fluid, before such lines are connected to the transmitter (blow-down). Do not allow steam to enter the measuring chamber. Observe operating safety rules during wiring, draining or blow-down.

Some examples of installation, illustrating the position of the transmitter in relation to the taps, are shown in Figure 1.3. The location of pressure taps and the relative position of the transmitter are indicated in Table 1.1.

Process Fluid	Location of Taps	Best Location for the LD303 in Relation to the Taps
Gas	Top or Side	Above the Taps
Liquid	Side	Below the Taps or at the Piping Centerline
Steam	Side	Below the Taps using Sealing (Condensate) Pots

Table 1.1 - Location of Pressure Taps

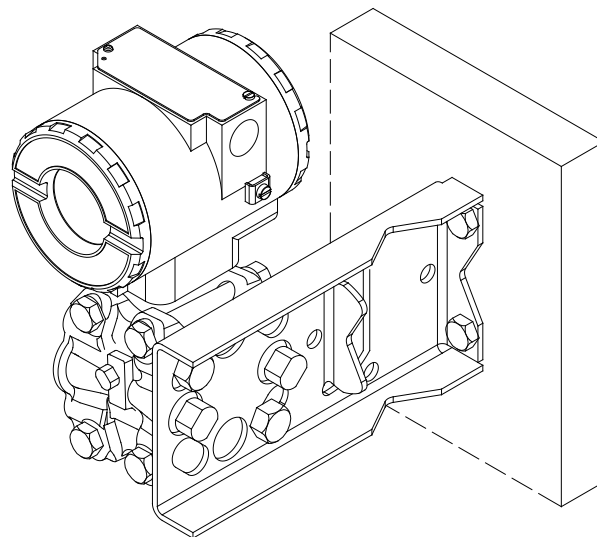

WALL OR PANEL MOUNTING
(See section 5 – spare parts list for mounting brackets available)

Figure 1.2 – Drawing Mounting of LD303 on the Panel or Wall

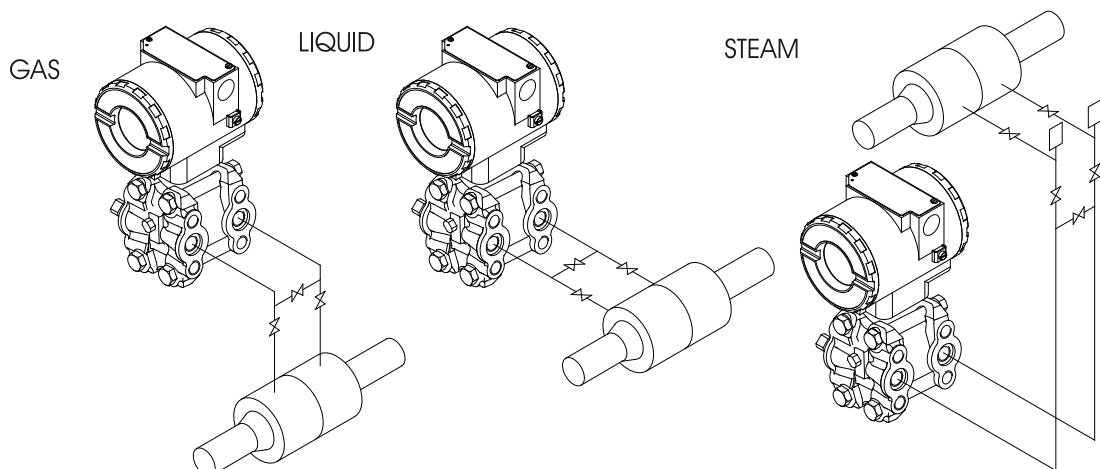

Figure 1.3 - Position of the Transmitter and Taps

NOTE

Except for dry gases, all impulse lines should slope at the ratio 1:10, in order to avoid trapping bubbles in the case of liquids, or condensation from steam or wet gases.

Housing Rotation

The housing can be rotated in order to get the digital display in better position. To rotate it, releases the Housing Rotation Set Screw. See Figure 1.4.

The digital display itself can also be rotated. In Section 4, See Figure 4.3.

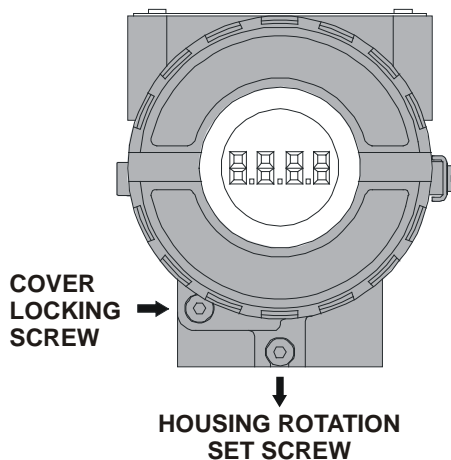

Figure 1.4 - Housing Rotation Set Screw

Reach the wiring block by removing the Electrical Connection Cover. This cover can be locked closed by the cover locking screw (Figure 1.5). To release the cover, rotate the locking screw clockwise.

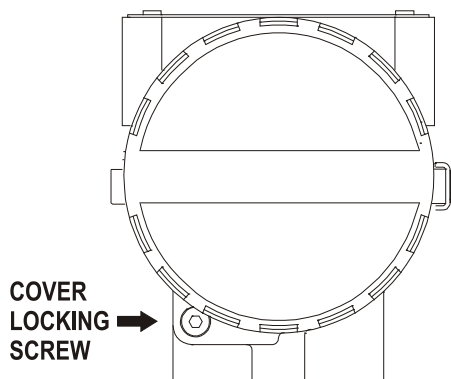

Figure 1.5 - Housing Rotation Set Screw

For convenience there are three ground terminals: one inside the cover and two externals, located close to the conduit entries. See figure 1.6.

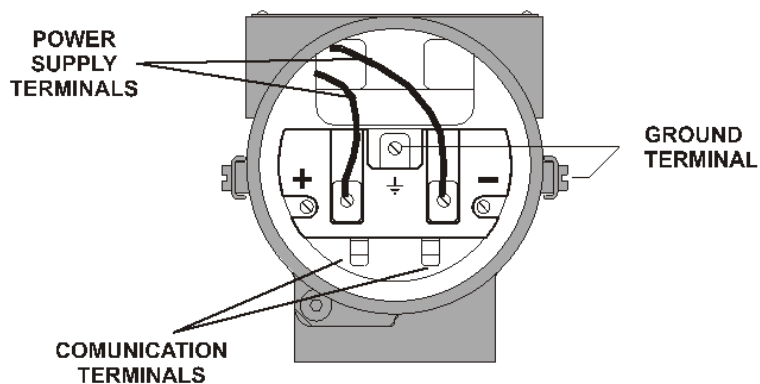

Figure 1.6 - Terminal Block

The **LD303** uses the 31.25 kbit/s voltage mode option for the physical signaling. All other devices on the same bus must use the same signaling. All devices are connected in parallel along the same pair of wires.

Various types of Profibus devices may be connected on the same bus.

The **LD303** is powered via the bus. The limit for such devices is according to the DP/PA coupler limitation for one bus for non-intrinsically safe requirement.

In hazardous area, the number of devices may be limited by intrinsically safe restrictions, according to the DP/PA coupler and barriers limitation.

The **LD303** is protected against reverse polarity, and can withstand ± 35 VDC without damage, but it will not operate when in reverse polarity.

The Figure 1.7 shows the correct installation of the conduit, in order to avoid penetration of water, or other substance, which may cause malfunctioning of the equipment.

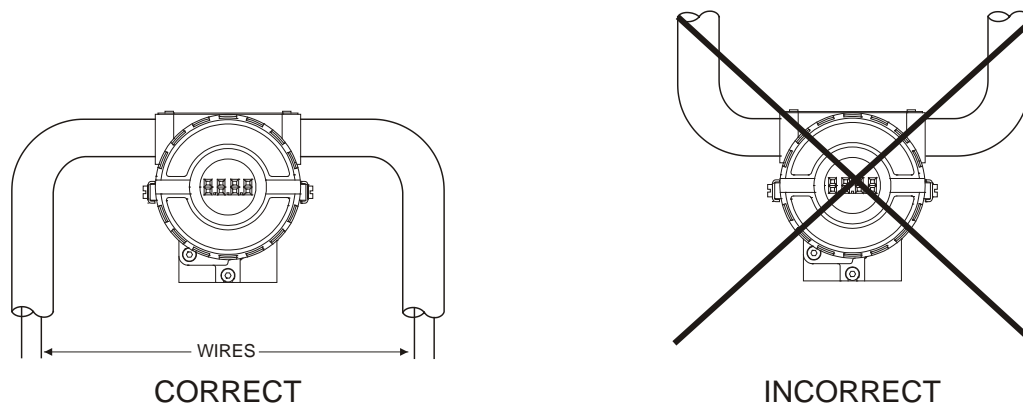

Figure 1.7 - Conduit Installation Diagram

NOTE

The transmitters are calibrated in the vertical position and a different mounting position displaces the zero point. Consequently, the indicator will indicate a different value from the applied pressure. In these conditions, it is recommended to do the zero pressure trim. The zero trim is to compensate the final assembly position and its performance, when the transmitter is in its final position. When the zero trim is executed, make sure the equalization valve is open and the wet leg levels are correct.

For the absolute pressure transmitter, the assembly effects correction should be done using the Lower trim, due to the fact that the absolute zero, is the reference for these transmitters, so there is no need for a zero value for the Lower trim.

When the sensor is in the horizontal position, the weight of the fluid pushes the diaphragm down, making it necessary a Lower Pressure Trim see Figure 1.8.

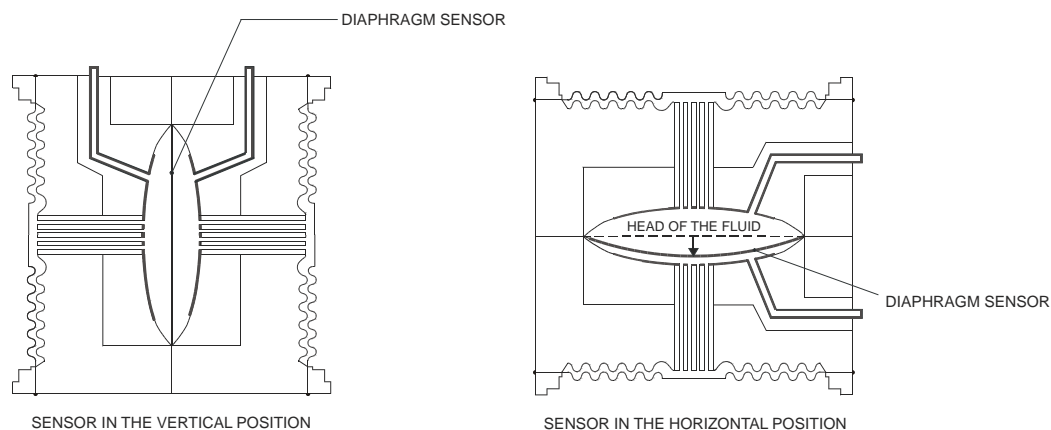

Figure 1.8 - Sensor Positions

NOTE

Please refer to the General Installation, Operation Manual and Maintenance Procedures Manual for more details.

NOTE

Please refer to the General Installation, Operation and Maintenance Procedures Manual for more details.

Bus Topology and Network Configuration

Wiring

Other types of cable may be used, other than for conformance testing. Cables with improved specifications may enable longer trunk length or superior interface immunity. Conversely, cables with inferior specifications may be used subject to length limitations for trunk and spurs plus possible nonconformance to the RFI/EMI susceptibility requirements. For intrinsically safe applications, the inductance/ resistance ratio (L/R) should be less than the limit specified by the local regulatory agency for the particular implementation.

Bus topology (See Figure 1.9) and tree topology (See Figure 1.10) are supported. Both types have a trunk cable with two terminations. The devices are connected to the trunk via spurs. The spurs may be integrated in the device giving zero spur length. A spur may connect more than one device, depending on the length. Active couplers may be used to extend spur length.

Active repeaters may be used to extend the trunk length.

The total cable length, including spurs, between any two devices in the Profibus should not exceed 1900 m.

The connection of couplers should be kept less than 15 per 250 m. In following figures the DP/PA link depends on the application needs.

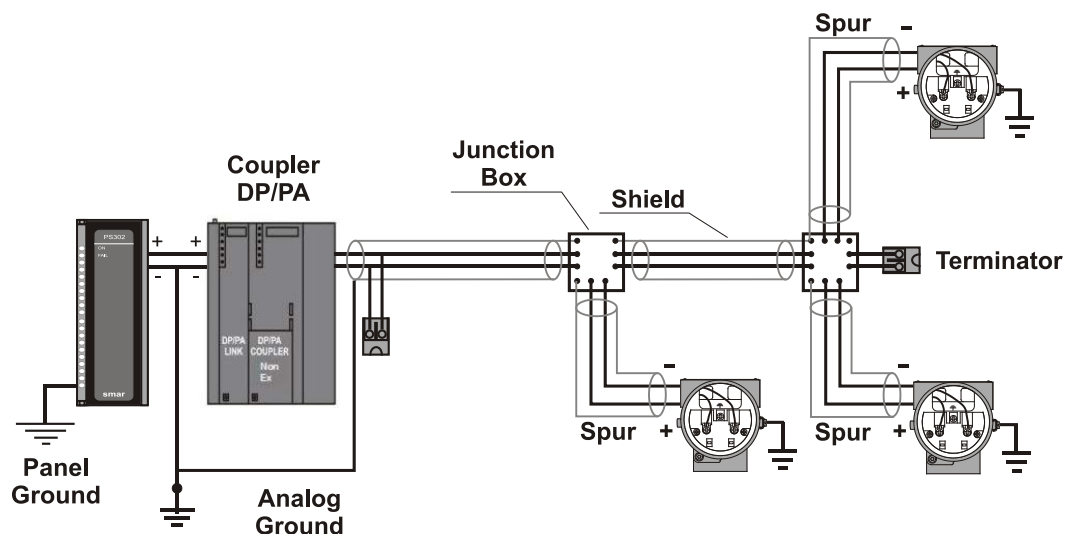

Figure 1.9 - Bus Topology

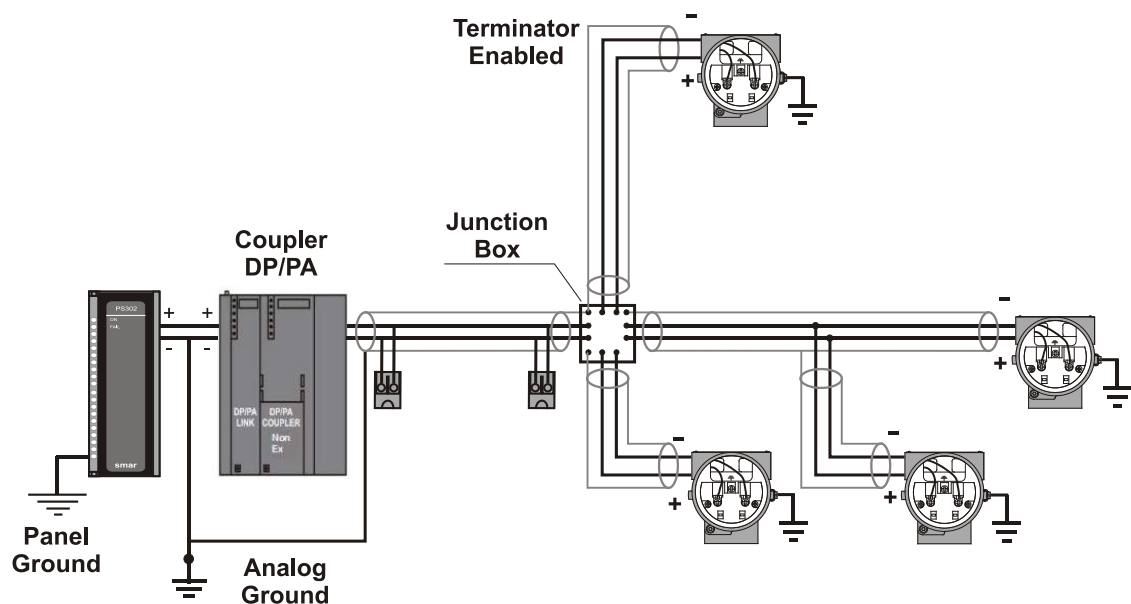

Figure 1.10 - Tree Topology

Intrinsic Safety Barrier

When the Profibus is in an area requiring intrinsic safety, a barrier must be inserted on the trunk between the power supply and the DP/PA coupler, when it is Non-Ex type.

Use of DF47 is recommended. See more in <http://www.smar.com/products/df47-12.asp>.

Jumper Configuration

In order to work properly, the jumpers J1 and W1 located in the LD303 main board must be correctly configured (See Table 1.2).

J1	This jumper enables the simulation mode parameter in the AI block.
W1	This jumper enables the local adjustment programming tree.

Table 1.2 - Description of the Jumpers

Power Supply

The **LD303** receives power from the bus via the signal wiring. The power supply may come from a separate unit or from another device such as a controller or DCS.

The voltage should be between 9 to 32 Vdc for non-intrinsic safe applications.

A special requirement applies to the power supply used in an intrinsically safe bus and depends on the type of barrier used.

Use of **PS302** is recommended as power supply.

Installation in Hazardous Areas

Consult the Appendix A for Hazardous Location Approvals.

OPERATION

The LD303 Series Pressure Transmitters use capacitive sensors (capacitive cells) as pressure sensing elements, as shown in Figure 2.1. This is exactly the same sensor as the LD301 series uses, the sensor modules are therefore interchangeable.

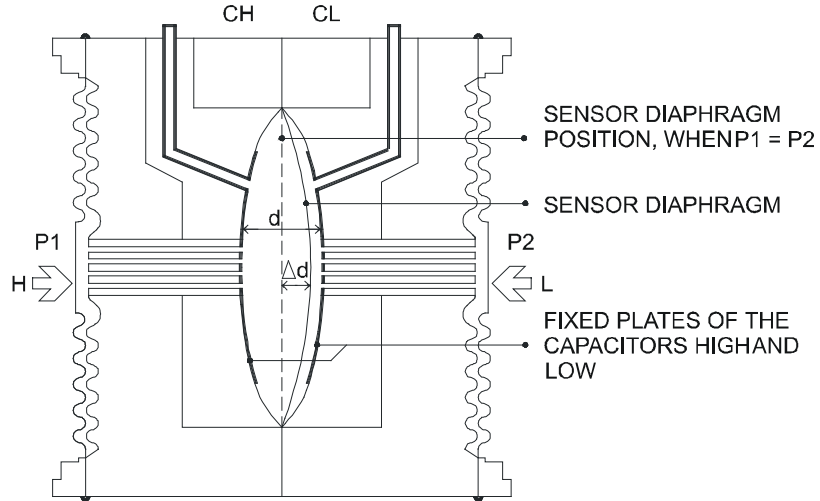

Figure 2.1 - Capacitive Cell

Functional Description - Sensor

Where,

P_1 and P_2 are the pressures and $P_1 \geq P_2$

CH = Capacitance between the fixed plate on P_1 side and the sensing diaphragm.

CL = Capacitance between the fixed plate on the P_2 side and the sensing diaphragm.

d = Distance between CH and CL fixed plates.

Δd = Sensing diaphragm's deflection due to the differential pressure $\Delta P = P_1 - P_2$.

Knowing that the capacitance of a capacitor with flat, parallel plates may be expressed as a function of plate area (A) and distance (d) between the plates:

$$C \approx \frac{\epsilon \times A}{d}$$

Where,

ϵ = Dielectric constant of the medium between the capacitor's plates.

$$CH \approx \frac{\epsilon \times A}{(d/2) + \Delta d} \quad \text{and} \quad \frac{\epsilon \times A}{(d/2) - \Delta d} \approx CL$$

However, should CH and CL be considered as capacitances of flat and parallel plates with identical areas, then:

However, should the differential pressure (ΔP) apply to the capacitive cell not deflect the sensing diaphragm beyond $d/4$, it is possible to assume ΔP as proportional to Δd , that is:

$$\Delta P \propto \Delta d$$

By developing the expression $(CL - CH)/(CL + CH)$, it follows that:

$$\frac{CL - CH}{CL + CH} = \frac{2\Delta d}{d}$$

As the distance (d) between the fixed plates CH and CL is constant. It is possible to conclude that the expression $(C_L - C_H)/(C_L + C_H)$ is proportional to Δd and, therefore, to the differential pressure to be measured.

Thus it is possible to conclude that the capacitive cell is a pressure sensor formed by two capacitors whose capacitances vary according to the applied differential pressure.

Functional Description – Electronics

Refer to the block diagram Figure 2.2. The function of each block is described below.

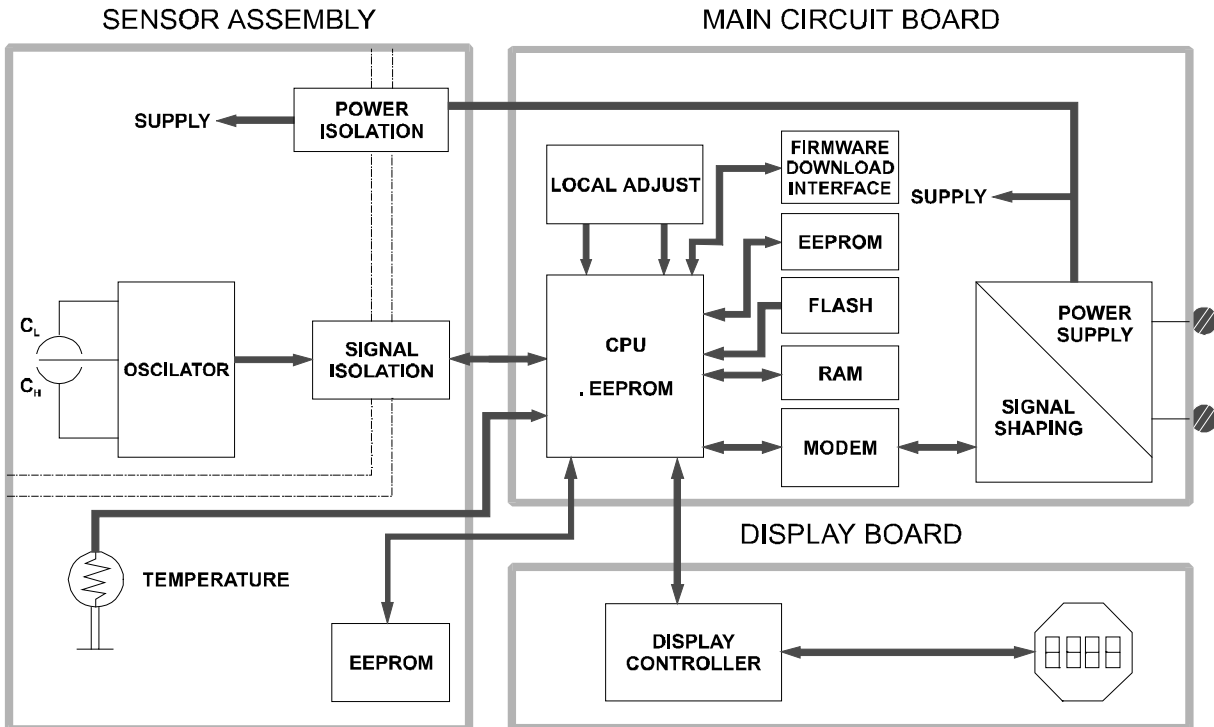

Figure 2.2 - LD303 Block Diagram Hardware

Oscillator

This oscillator generates a frequency as a function of sensor capacitance.

Signal Isolator

The control signals from the CPU and the signal from the oscillator are isolated to avoid ground loops.

Central Processing Unit (CPU), RAM, FLASH and EEPROM

The CPU is the intelligent portion of the transmitter, being responsible for the management and operation of measurement, block execution, self-diagnostics and communication. The program is stored in a FLASH memory for easy upgrade and saving data on power-down event occurrence. For temporary storage of data there is a RAM. The data in the RAM is lost if the power is switched off, however the main board has a nonvolatile EEPROM memory where the static data configured that must be retained is stored. Examples of such data are the following: calibration, links and identification data.

Sensor EEPROM

Another EEPROM is located within the sensor assembly. It contains data pertaining to the sensor's characteristics at different pressures and temperatures. This characterization is done for each sensor at the factory. It also contains the factory settings; they are useful in case of main board replacement, when it does an automatic upload of data from the sensor board to main board.

Profibus Modem

Monitors line activity, modulate and demodulate communication signals, inserts and deletes start and end delimiters, and checks integrity of frame received.

Power Supply

Takes power of the loop-line to power the transmitter circuitry.

Power Isolation

Isolates the signals to and from the input section, the power to the input section must be isolated.

Display Controller

Receives data from the CPU identifying which segments on the liquid crystal Display use to turn on. The controller drives the backplane and the segment control signals.

Local Adjustment

There are two switches that are magnetically activated. The magnetic tool without mechanical or electrical contact can activate them.

Display

The integral indicator is able to display one or two variables, which are user selectable. When two variables are chosen, the display will alternate between the two with an interval of 3 seconds.

The liquid crystal display includes a field with 4 ½ numeric digits, a field with 5 alphanumeric digits and an information field, as shown on Figure 2.3.

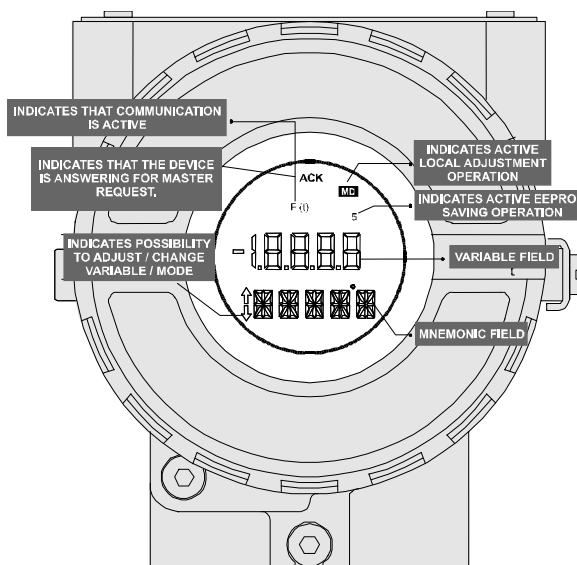

Figure 2.3 - LCD Indicator

CONFIGURATION

This section describes the characteristics of the blocks in the **LD303**. They follow the Profibus PA specifications, but in terms of transducer blocks, the input transducer block and display, they have some special features on top of this.

The 303 Smar family is integrated in Profibus View from Smar and Simatic PDM from Siemens. It is possible to integrate any 303 Smar devices into any configuration tool for Profibus PA devices. It is necessary to provide a Device Description or Drive according to the configuration tool. In this manual is taken several examples using Profibus View or Simatic PDM.

In order to assure correct values in the offline configuration, first run "Download to PG/PC" option to assure valid values. After, run the Menu Device option to configure the required parameters using the related menus.

NOTE
In offline configuration, it is not advisable to use the "Download to Device" option. This function can misconfigure the equipment.

Transducer Block

Transducer block insulates function block from the specific I/O hardware, such as sensors, actuators. Transducer block controls access to I/O through manufacturer specific implementation. This permits the transducer block to execute as frequently as necessary to obtain good data from sensors without burdening the function blocks that use the data. It also insulates the function block from the manufacturer specific characteristics of certain hardware.

By accessing the hardware, the transducer block can get data from I/O or passing control data to it. The connection between Transducer block and Function block is called channel. These blocks can exchange data from its interface.

Normally, transducer blocks perform functions, such as linearization, characterization, temperature compensation, control and exchange data to hardware.

Transducer Block Diagram

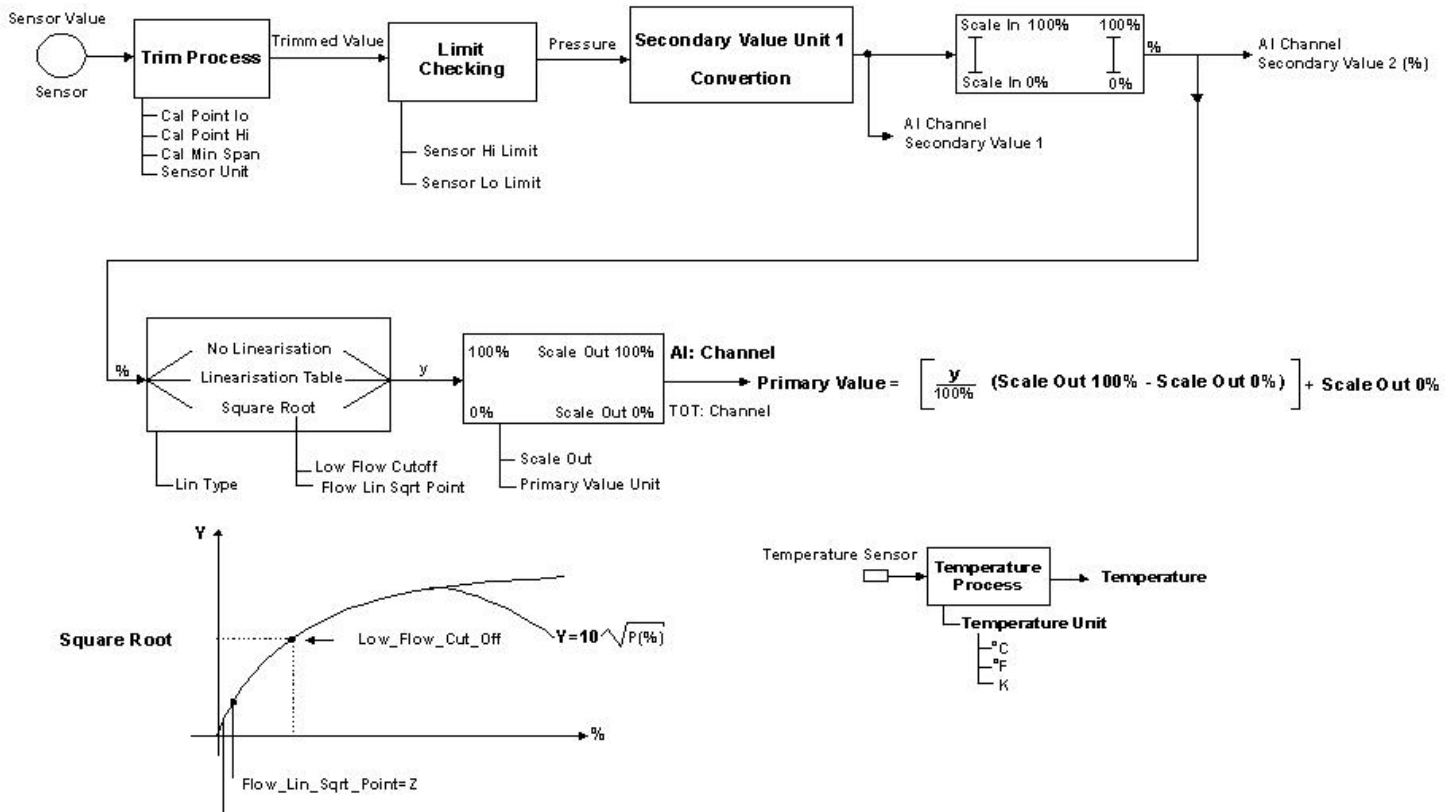

Figure 3.1 – Transducer Block Diagram

Pressure Transducer Block Parameter Description

Parameter	Description
BACKUP_RESTORE	This parameter allows to save and to restore data according to factory and user calibration procedures. It has the following options: 1, "Factory Cal Restore", 2, "Last Cal Restore", 3, "Default Data Restore", 4, "Shut-Down Data Restore", 5, "Sensor Data Restore", 11, "Factory Cal Backup", 12, "Last Cal Backup", 14, "Shut-Down Data Backup", 15, "Sensor Data Backup", 0, "None".
CAL_MIN_SPAN	This parameter contains the minimum calibration span value allowed. This minimum span information is necessary to ensure that when calibration is done, the two calibrated points (high and low) are not too close together. Unit derives from SENSOR_UNIT.
CAL_POINT_HI	This parameter contains the highest calibrated value. For calibration of the high limit point you give the high measurement value (pressure) to the sensor and transfer this point as HIGH to the transmitter. Unit derives from SENSOR_UNIT.
CAL_POINT_LO	This parameter contains the lowest calibrated value. For calibration of the low limit point you give the low measurement value (pressure) to the sensor and transfer this point as LOW to the transmitter. Unit derives from SENSOR_UNIT.
CAL_TEMPERATURE	This parameter contains the calibrated temperature value. Unit derives from TEMPERATURE_UNIT.
COEFF_POL	This parameter contains the polynomial coefficients.

Parameter	Description
DEAD_BAND_BYPASS	This parameter is used to enable the zero cutoff. { 1, "True" } { 0, "False" }
EEPROM_FLAG	This parameter is used to indicate EEPROM saving process. { 0, "False" } { 1, "True" }
FACTORY_CURVE_BYPASS	This parameter is used to enable factory characterization curve. { 85, "Disable" } { 170, "Enable and Backup Cal" } { 4010, "Disable and Restore Cal" } { 61440, "Disable or Allows to enter the points" }
FACTORY_CURVE_X	This parameter contains input points of factory characterization curve.
FACTORY_CURVE_Y	This parameter contains input points of factory characterization curve.
FACTORY_CURVE_LENGTH	This parameter contains the number of points of factory characterization curve
FLOW_LIN_SQRT_POINT	This is the point of the flow function where the curve changes from linear to square root function. The input has to be done in percent of flow.
LIN_TYPE	Linearization – Type: 0 – No Linearization 1 – User Defined Table 10 – Square Root
LOW_FLOW_CUT_OFF	This is the point in percent of flow till that the output of the flow function is set to zero. It is used for suppressing low flow values.
MAIN_BOARD_SN	This is the main board serial number.
MAX_SENSOR_VALUE	Holds the maximum process SENSOR_VALUE. A write access to this parameter resets to the momentous value. The unit is defined in SENSOR_UNIT.
MIN_SENSOR_VALUE	Holds the minimum process SENSOR_VALUE. A write access to this parameter resets to the momentous value. The unit is defined in SENSOR_UNIT.
MAX_TEMPERATURE	Holds the maximum temperature. A write access to this parameter resets to the momentous value.
MIN_TEMPERATURE	Holds the minimum temperature. A write access to this parameter resets to the momentous value.
ORDERING_CODE	Indicates information about the sensor and control from production factory.
POLYNOMIAL_VERSION	Indicates the polynomial version.
PRESS_LIN_NORMAL	Indicates the Linear Normalized Pressure.
PRESS_NORMAL	Indicates Normalized Pressure.
PRIMARY_VALUE	This parameter contains the measured value and status available to the Function Block. The unit of PRIMARY_VALUE is the PRIMARY_VALUE_UNIT.
PRIMARY_VALUE_TYPE	This parameter contains the application of the pressure device. 0: Pressure 1: Flow 2: Level 3: Volume 4-127: reserved > 128: manufacture specific
PRIMARY_VALUE_UNIT	This parameter contains the engineering units index code for the primary value. See explanation about Primary_Value_Unit.
PROCESS_CONNECTION_MATERIAL	Not used.
PROCESS_CONNECTION_TYPE	Not used.
SCALE_IN	This is the input conversion of the Pressure into SECONDARY_VALUE_2 using the high and low scale. The related unit is the SECONDARY_VALUE_1_UNIT.
SCALE_OUT	This is the output conversion of the linearized value using the high and low scale. The related unit is the PRIMARY_VALUE_UNIT.
SECONDARY_VALUE_1	This parameter contains the Pressure value and status available to the Function Block.
SECONDARY_VALUE_1_UNIT	This parameter contains the pressure units of the SECONDARY_VALUE_1.
SECONDARY_VALUE_2	This parameter contains the measured value after input scaling and status available to the Function Block. The related unit is the SECONDARY_VALUE_UNIT_2.

Parameter	Description
SECONDARY_VALUE_2_UNIT	This parameter contains the units of the SECONDARY_VALUE_2 defined by the manufacturer
SENSOR_DIAPHRAGM_MATERIAL	This parameter contains the index code for the material of the diaphragm, which comes in contact with the process media.
SENSOR_FILL_FLUID	This parameter contains the index code for the fill fluid inside the sensor. The index code is manufacture specific.
SENSOR_MAX_STATIC_PRESSURE	Not used.
SENSOR_O_RING_MATERIAL	Not used.
SENSOR_HI_LIM	This parameter contains the sensor upper limit value. Unit derives from SENSOR_UNIT.
SENSOR_LO_LIM	This parameter contains the sensor lower limit value. Unit derives from SENSOR_UNIT.
SENSOR_RANGE_CODE	Indicates the sensor range code. { 0, "Range 1 (20 inH2O)" }, { 1, "Range 2 (200 inH2O)" }, { 2, "Range 3 (1000 inH2O)" }, { 3, "Range 4 (360 psi)" }, { 4, "Range 5 (3600 psi)" }, { 5, "Range 6 (5800 psi)" }, { 253, "Special" }
SENSOR_SERIAL_NUMBER	This parameter contains the sensor serial number.
SENSOR_TYPE	This parameter contains the index code for the sensor type described in the manufacturer's specific table. {117, "Capacitance"}
SENSOR_UNIT	This parameter contains the engineering units index code for the calibration values. See Table 3.4.
SENSOR_VALUE	This parameter contains the raw sensor value. The uncalibrated measurement value from the sensor. Unit derives from SENSOR_UNIT.
TAB_ACTUAL_NUMBER	Contains the actual numbers of entries in the table. It shall be calculated after the transmission of the table is finished.
TAB_INDEX	The index parameter identifies which element of the table is in the X_VALUE and Y_VALUE parameter currently
TAB_MAX_NUMBER	TAB_MAX_NUMBER is the maximum size (number of X_VALUE and Y_VALUE values) of the table in the device.
TAB_OP_CODE	The modification of a table in a device influences the measurement or actuation algorithms of the device. Therefore an indication of a starting and an end point is necessary. The TAP_OP_CODE controls the transaction of the table. 0: not initialized 1: new operation characteristic, first value (TAB_ENTRY=1), old curve cleared 2: reserved 3: last value, end of transmission, check table, swaps the old curve with the new curve, actualize ACTUAL_NUMBER. 4: delete point of table with actual index (optional), sort records with increasing Charact-Input-Value, assign new indexes, and decrement CHARACT_NUMBER. 5: insert point (Charact-Input-Value relevant) (optional), sort records with increasing Charact-Input-Value, assign new indexes. Increment CHARACT_NUMBER. 6: replace point of table with actual index (optional).
TAB_STATUS	It is common to provide a plausibility check in the device. The result of this check is indicated in the TAB_STATUS parameter. 0: not initialized 1: good (new table is valid) 2: not monotonous increasing (old table is valid) 3: not monotonous decreasing (old table is valid) 4: not enough values transmitted (old table is valid) 5: too many values transmitted (old table is valid) 6: gradient of edge too high (old table is valid) 7: Values not excepted (old values are valid) 8 - 127 reserved > 128 manufacturer specific
TAB_X_Y_VALUE	The X_Y_VALUE parameter contains one value couple of the table.

Parameter	Description
TEMPERATURE	This parameter contains the temperature (e.g. sensor temperature used for measurement compensation) with the associated status used within the transducer. The unit of TEMPERATURE is the TEMPERATURE_UNIT.
TEMPERATURE_UNIT	This parameter contains the units of the temperature. The unit codes are: K (1000), °C (1001), and °F (1002).
TRD_TRANSDUCER_TYPE	Indicates the type of pressure transmitter: 107, differential; 108, gauge; 109, absolute; 65535, others/special.
TRIMMED_VALUE	This parameter contains the sensor value after the trim processing. Unit derives from SENSOR_UNIT.
XD_ERROR	Indicates the condition of calibration process according to: {16, "Default value set"}, {22, "Applied process out of range"}, {26, "Invalid configuration for request"}, {27, "Excess correction"}, {28, "Calibration failed"}

Table 3.1 - Pressure Transducer Block Parameter Description

Pressure Transducer Block Parameter Attributes

Rel. Index	Parameter	Object Type	Data Type	Storage	Size	Access	Parameter usage/ Type of transport	Default – value	Down-load Order	Mandatory / Optional (Class)	View
... Standard Parameter											
Additional Parameter for Transducer Block											
8	SENSOR_VALUE	Simple	Float	D	4	r	C/a	0	-	M (B)	
9	SENSOR_HI_LIM	Simple	Float	N	4	r	C/a	0	-	M (B)	
10	SENSOR_LO_LIM	Simple	Float	N	4	r	C/a	0	-	M (B)	
11	CAL_POINT_HI	Simple	Float	N	4	r,w	C/a	5080.0	-	M (B)	
12	CAL_POINT_LO	Simple	Float	N	4	r,w	C/a	0.0	-	M (B)	
13	CAL_MIN_SPAN	Simple	Float	N	4	r	C/a	0	-	M (B)	
14	SENSOR_UNIT	Simple	Unsigned 16	N	2	r,w	C/a	1151	2	M (B)	
15	TRIMMED_VALUE	Record	DS-33	D	5	r	C/a	0.0	-	M (B)	
16	SENSOR_TYPE	Simple	Unsigned 16	N	2	r	C/a	117	-	M (B)	
17	SENSOR_SERIAL_NUMBER	Simple	Unsigned 32	N	4	r,w	C/a	0	-	M (B)	
18	PRIMARY_VALUE	Record	DS-33	D	5	r	C/a	0.0	-	M (B)	1
19	PRIMARY_VALUE_UNIT	Simple	Unsigned 16	N	2	r,w	C/a	1151	3	M (B)	
20	PRIMARY_VALUE_TYPE	Simple	Unsigned 16	N	2	r,w	C/a	100	-	M (B)	
21	SENSOR_DIAPHRAGM_MATERIAL	Simple	Unsigned 16	S	2	r,w	C/a	2	-	O (B)	
22	SENSOR_FILL_FLUID	Simple	Unsigned 16	S	2	r,w	C/a	2	-	O (B)	
23	SENSOR_MAX_STAT_IC_PRESSURE	Not used.									
24	SENSOR_O_RING_MATERIAL	Not used.									
25	PROCESS_CONNECTION_TYPE	Not used.									
26	PROCESS_CONNECTION_MATERIAL	Not used.									
27	TEMPERATURE	Record	DS-33	D	5	r	C/a	0.0	-	O (B)	
28	TEMPERATURE_UNIT	Simple	Unsigned 16	N	2	r,w	C/a	1001	4	O (B)	
29	SECONDARY_VALUE_1	Record	DS-33	D	5	r	C/a	0.0	-	O (B)	
30	SECONDARY_VALUE_1_UNIT	Simple	Unsigned 16	N	2	r,w	C/a	1151	5	O (B)	
31	SECONDARY_VALUE_2	Record	DS-33	D	5	r	C/a	0	-	O (B)	
32	SECONDARY_VALUE_2_UNIT	Simple	Unsigned 16	N	2	r,w	C/a	1151	6	O (B)	
33	LIN_TYPE	See explanation about table handling							1	M (B)	
34	SCALE_IN	Array	Float	S	8	r,w	C/a	5080.0	7	O(B)	
35	SCALE_OUT	Array	Float	S	8	r,w	C/a	0.0	8	O (B)	
36	LOW_FLOW_CUT_OFF	Simple	Float	S	4	r,w	C/a	0.0	-	O (B)	
37	FLOW_LIN_SQRT_POINT	Simple	Float	S	4	r,w	C/a	0.0	-	O (B)	
38	TAB_ACTUAL_NUMBER	See explanation about table handling									
39	TAB_INDEX	See explanation about table handling									
40	TAB_MAX_NUMBER	See explanation about table handling									

Rel. Index	Parameter	Object Type	Data Type	Storage	Size	Access	Parameter usage/ Type of transport	Default – value	Down-load Order	Mandatory / Optional (Class)	View	
41	TAB_MIN_NUMBER	See explanation about table handling										
42	TAB_OP_CODE	See explanation about table handling										
43	TAB_STATUS	See explanation about table handling										
44	TAB_X_Y_VALUE	See explanation about table handling										
45	MAX_SENSOR_VALU E	Simple	Float	N	4	r,w	C/a	0.0	-	O (B)		
46	MIN_SENSOR_VALU E	Simple	Float	N	4	r,w	C/a	0.0	-	O (B)		
47	MAX_TEMPERATUR E	Simple	Float	N	4	r,w	C/a	0.0	-	O (B)		
48	MIN_TEMPERATURE	Simple	Float	N	4	r,w	C/a	0.0	-	O (B)		
49	RESERVED BY PNO											
50	RESERVED BY PNO											
51	RESERVED BY PNO											
52	RESERVED BY PNO											
53	RESERVED BY PNO											
54	RESERVED BY PNO											
55	RESERVED BY PNO											
56	RESERVED BY PNO											
57	RESERVED BY PNO											
58	RESERVED BY PNO											
59	RESERVED BY PNO											
60	CAL_TEMPERATURE	Simple	Float	N	4	r,w	C/a	25.0	-	O (B)		
61	BACKUP_RESTORE	Simple	Unsigned 8	S	1	r,w	C/a	0	-	O (B)		
62	FACTORY_CURVE_B YPASS	Simple	Unsigned 16	S	2	r,w	C/a	0x0F	-	O (B)		
63	FACTORY_CURVE_X	Array	Float	S	20	r,w	C/a	-	-	O (B)		
64	FACTORY_CURVE_Y	Array	Float	S	20	r,w	C/a	-	-	O (B)		
65	FACTORY_CURVE_L ENGTH	Simple	Unsigned 8	S	1	r,w	C/a	5	-	O (B)		
66	PRESS_LIN_NORMA L	Record	DS-33	D	5	r	C/a	0.0	-	O (B)		
67	PRESS_NORMAL	Record	DS-33	D	5	r	C/a	0.0	-	O (B)		
68	DEAD BAND_BYPASS	Simple	Unsigned 8	S	1	r,w	C/a	TRUE	-	O (B)		
69	COEFF_POL	Array	Float	S	48	r,w	C/a	-	-	O (B)		
70	POLYNOMIAL_VERSI ON	Simple	Unsigned 8	S	1	r,w	C/a	0x32	-	O (B)		
71	SENSOR_RANGE_C ODE	Simple	Unsigned 8	S	1	r,w	C/a	1	-	O (B)		
72	TRD_TRANSDUCER_ TYPE	Simple	Unsigned 16	S	2	r,w	C/a	107	-	O (B)		
73	XD_ERROR	Simple	Unsigned 8	D	1	r	C/a	0x10	-	O (B)		
74	MAIN_BOARD_SN	Simple	Unsigned 32	S	4	r,w	C/a	0	-	O (B)		
75	EEPROM_FLAG	Simple	Unsigned 8	D	1	r	C/a	FALSE	-	O (B)		
76	ORDERING_CODE	Array	Unsigned 8	S	50	r,w	C/a	-	-	O (B)		

Table 3.2 Pressure Transducer Blocks Parameter Attributes

LD303 - Cyclic Configuration

The PROFIBUS-DP and PROFIBUS-PA protocols have mechanisms against communication failures between the slave device and the network master. For example, during initialization, these mechanisms are used to check these possible errors. After powering up the field device (slave), it can cyclically exchange information with the class 1 master, if the parameterization for the slave is correct. This information is obtained using the GSD files (supplied by the device manufacturer, it contains their descriptions). Through the commands below, the master executes all initialization process with the PROFIBUS-PA device:

- Get_Cfg: uploads the slave configuration on the master and checks network configuration;
- Set_Prm: writes to the slave parameters and executes the parameterization network;
- Set_Cfg: configures the slaves according to its outputs and inputs;
- Get_Cfg: another command, where the master checks the slave configuration.

All these services are based on the information obtained from slave GSD files. The GSD file from **LD303** shows details such as, hardware and software revision, device bus timing and information about cyclic data exchange.

LD303 has two function blocks: one AI (Analog Input) and one TOT (Totalizer). It also has the empty module for applications where not all function blocks are necessary. The following cyclic order of the blocks should be respected: AI and TOT. Suppose, only the AI block is necessary, then configure this way: AI, EMPTY_MODULE.

Most PROFIBUS configuration tools use two directories where the different manufacturers' GSD's and BITMAPS files are stored. The GSD's and BITMAPS for Smar devices can be obtained through the website: (<https://www.smar.com>), on the 'download' link.

The following example shows the necessary steps to integrate the **LD303** on a Profibus system.

These steps are valid for the entire 303 line of Smar devices:

- Copy the **LD303** gsd file to the research directory of the PROFIBUS configuration tool, usually called GSD;
- Copy the **LD303** bitmap file to the research directory of the PROFIBUS configuration tool usually called BMP;
- After choosing the master, define the baud rate for the network. Do not forget that couplers may work with the following baud rate: 45.45 kbits/s (Siemens model), 93.75 kbits/s (P+F model) and 12 Mbits/s (P+F, SK2 model). The IM157 device link (Siemens model) may work up to 12 Mbits/s;
- Add the **LD303** and specify its physical bus address;
- Choose the cyclic configuration via parameterization using the gsd file that depends on the application, as detailed previously. For every AI (Analog Input) block, the **LD303** provides the process variable to the master in 5 bytes value, being the first four according to float point data type and the fifth byte is the status that brings the measure quality of this information.

In the TOT (Totalizer) block, the user can choose the totalization value (Total) and the integration is made considering the operation mode (Mode_Tot). It allows defining of how the totalization will be, with the following options: only positive value of the flow, only negative values of the flow, or both. In this block, the user can reset the totalization and configure the preset value through the Set_Tot parameter. The reset option is very used in batch processes;

It allows activating the condition of watchdog, which the device goes to a fail safe condition, when a loss of communication is detected with the master.

How to Configure the Transducer Block

The transducer block has an algorithm, a set of contained parameters and a channel connecting it to a function block.

The algorithm describes the behavior of the transducer as a data transfer function between the I/O hardware and other function block. The set of contained parameters, it means, you are not able to link them to other blocks and publish the link via communication, defines the user interface to the transducer block. They can be divided into Standard and Manufacturer Specific.

The standard parameters will be present for such class of device, as pressure, temperature, actuator, etc., whatever is the manufacturer. Oppositely, the manufacturers specific ones are defined only for its manufacturer. As common manufacturer specific parameters, we have calibration settings, material information, linearization curve, etc.

When you perform a standard routine as a calibration, you are conducted step by step by a method. The method is generally defined as guide line to help the user to make common tasks. The configuration tool identifies each method associated to the parameters and enables the interface to it.



The Profibus View from Smar and Simatic PDM (Process Device Manager), from configuration softwares, for example, can configure many parameters of the Input Transducer block. See figure 3.2 and 3.3.

Figure 3.2 - Function and Transducers Blocks – Profibus View

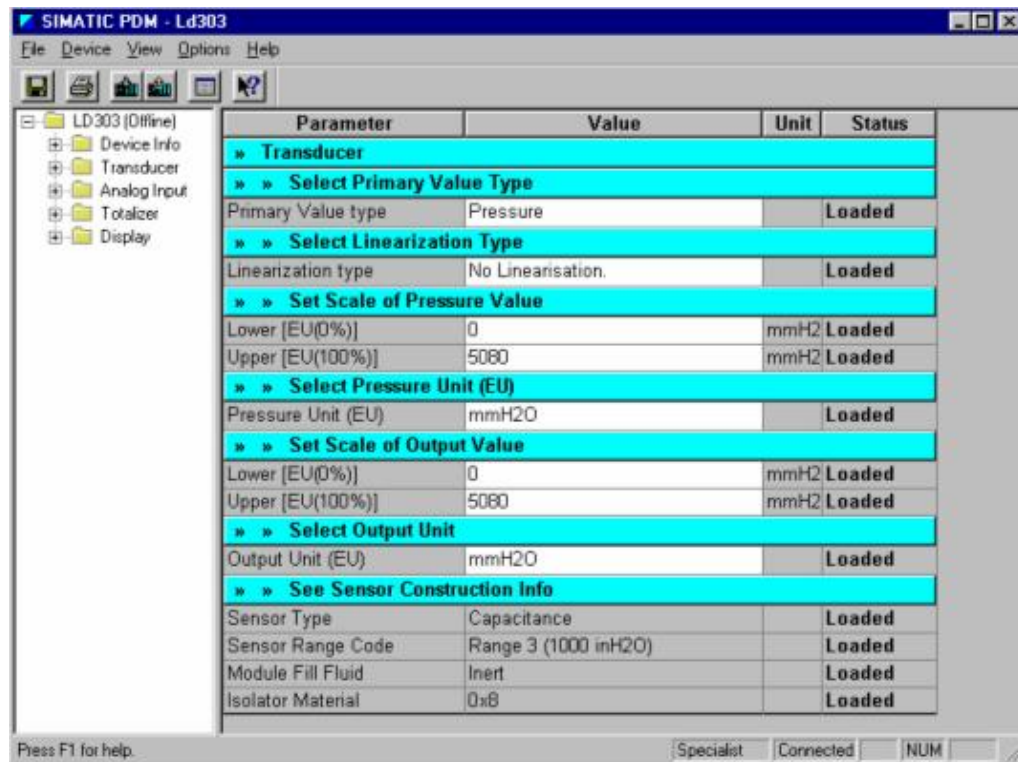

Figure 3.3 - Function and Transducers Blocks – Simatic PDM



To make the configuration of Transducer Block, we need to select the menu "Device".

Use this menu:

- To change the device address;
- To make the up/download of parameters;
- To configure the Transducer Blocks, Analog Blocks and Display Block;
- To calibrate the transmitter;
- To make the reset by software, to protect the device against writing and to simulate the value from transducer block to analog block;
- To save and restore data calibration.

Depending on the application, select "Pressure" or "Flow".

The user can select the linearization according to his application.

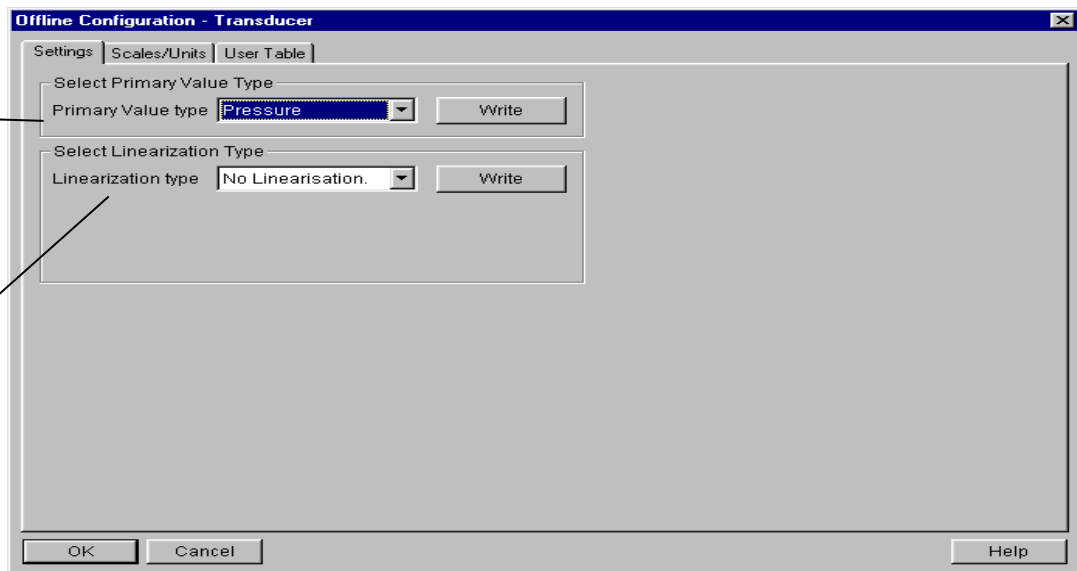

Figure 3.4 – Office Configuration – Transducer

Using this window, the user can set the Primary Value Type according to his application, selecting "Pressure" or "Flow".

Also, the user can select the Linearization Type, choosing "No Linearization", "Square Root" or "User Defined (Table)".

When the user desires to make the square root of pressure is necessary to set Primary Value Type to "Flow".



Using the next window the user can configure the units according to the Transducer Block Diagram:

The User can select the unit and scaling for pressure.

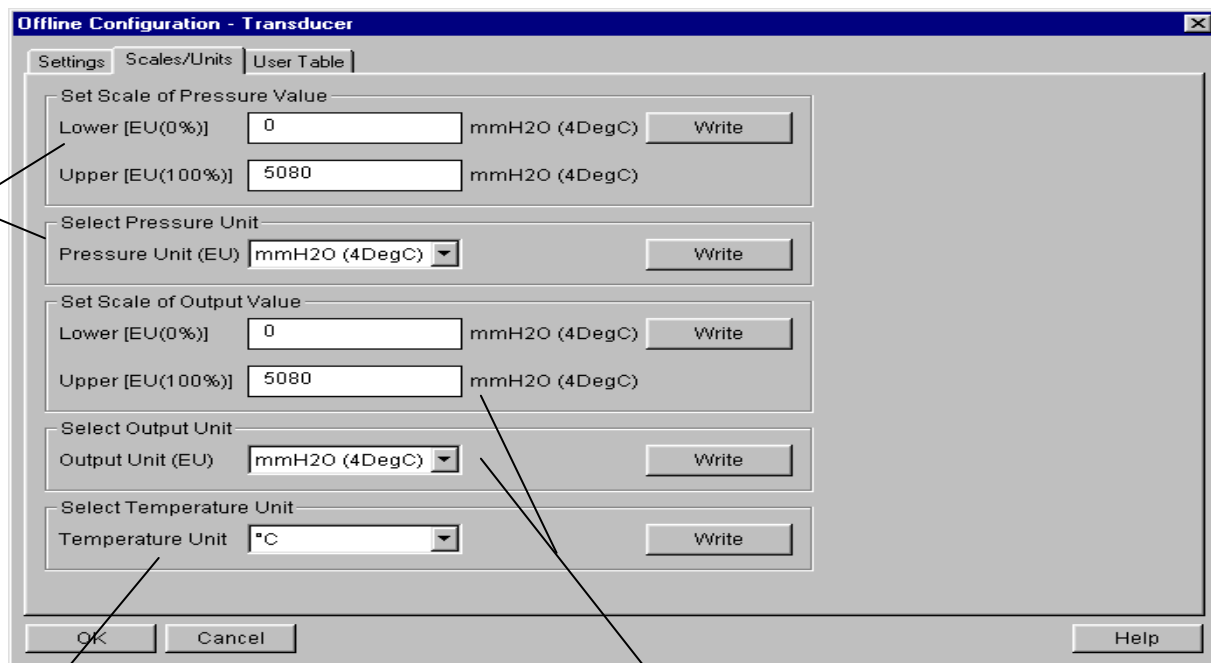

The User can select the temperature unit.

The User can select the output unit and output scaling according to his application.

Figure 3.5 – Scale Units for Transducer Block

Table handling



There is the possibility to load and re-load tables in the devices. This table is used for linearization mostly. For this procedure the following parameters are necessary:

TAB_INDEX
 TAB_X_Y_VALUE
 TAB_MIN_NUMBER
 TAB_MAX_NUMBER
 TAB_OP_CODE
 TAB_STATUS

The TAB_X_Y_VALUE parameter contains the value couple of the each table entries.

The TAB_INDEX parameter identifies which element of the table is in the TAB_X_Y_VALUE parameter currently (see the following figure).

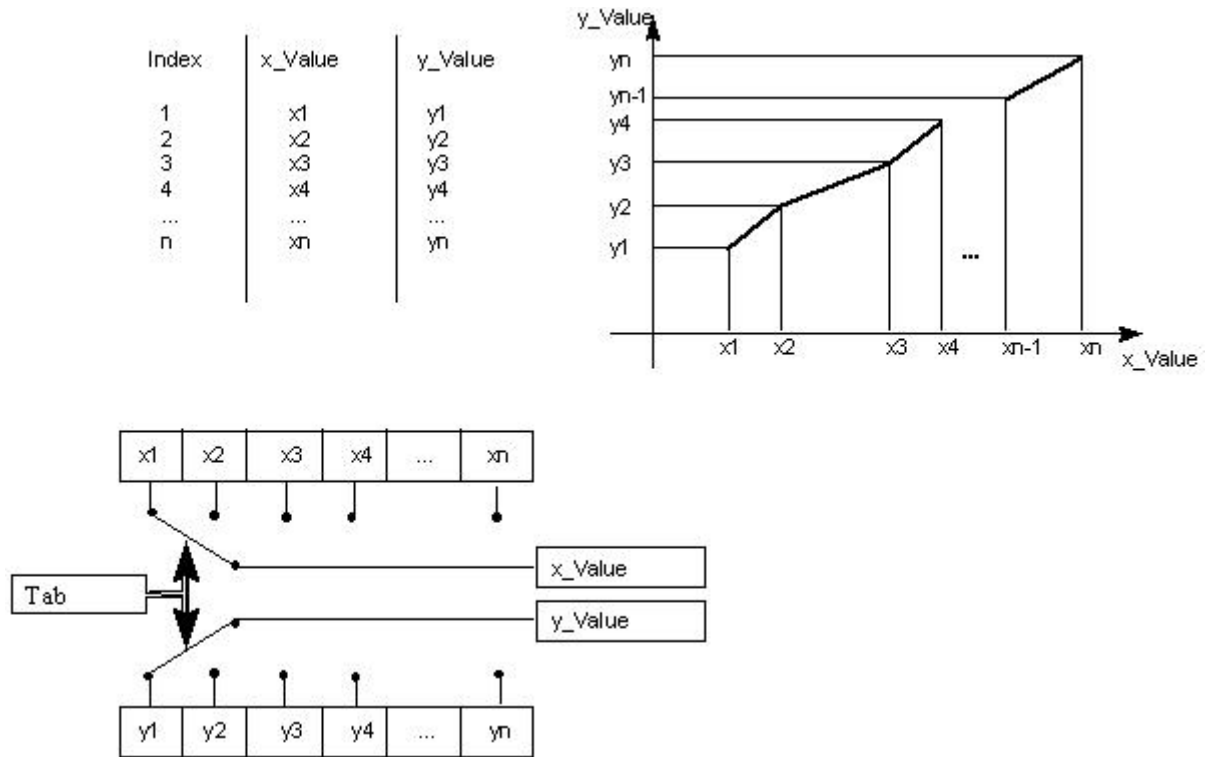

Figure 3.6 – Parameters of a Table

TAB_MAX_NUMBER is the maximum size of the table in the device. TAB_MIN_NUMBER is the minimum size of the table in the device.

The modification of a table in the device influences the measurement algorithms of the device. Therefore an indication of a starting and an endpoint is necessary. The TAB_OP_CODE controls the transaction of the table. The device provides a plausibility check. The result of this check is indicated in the TAB_STATUS parameter.

The User Table is used to make the pressure characterization in several points.

The user can configure up to 21 points in percentage unit.

The sensor characteristic curve at a certain temperature and for certain ranges may be slightly nonlinear.

This eventual non-linearity may be corrected through the User Table.

The user just needs to configure the input values and the correspondent output values in %.

Configure a minimum of two points. These points will define the characterization curve. The maximum number of points is 21. It is recommended to select the points equally distributed over the desired range or over a part of the range where more accuracy is required.

Go to "Device Off Line Configuration Transducer" window and select "user defined (table)".

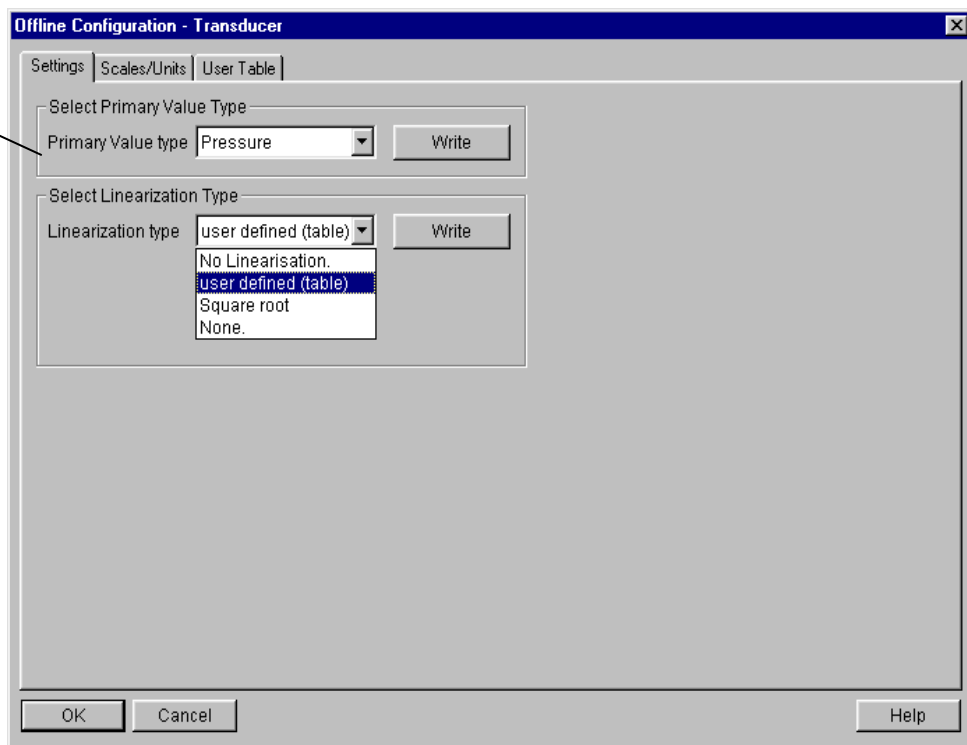
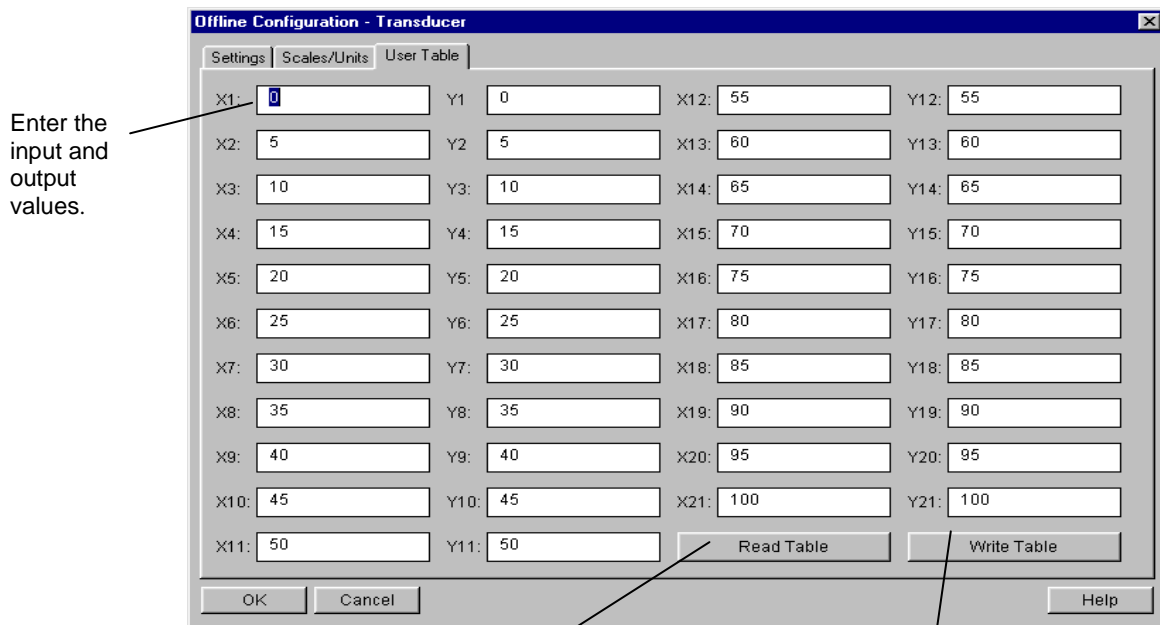

Figure 3.7 – Transducer Offline Configuration Screen

Using the menu Table, the user can configure the points.

The user also can read the configurable table and write a new one. In this case, the table must be monotonous increasing; otherwise, the points will not be configurable. Please see the following figure:



Enter the input and output values.

Allows the reading of configurable table.

After configuring the points, this key must be press to verify if the table is monotonous increasing.

Figure 3.8 – Transducer Off Line Configuration – User Table Screen

See the Transducer Block configuration screens below using the Profibus View.

The screenshot shows a software interface for configuring a transducer block. At the top, there are navigation tabs: "Settings", "Scales / Units", "User Table", and "Backup/Restore". The main title is "Transducer Block" in a large, bold font. To the right of the title is a small image of a transducer. Below the title, there are three sections, each with a dropdown menu:

- Primary Value Type:** The dropdown menu is set to "Pressure".
- Transducer Type:** The dropdown menu is set to "Differential".
- Linearization Type:** The dropdown menu is set to "No Linearisation".

At the bottom right of the screen, there are two buttons: "Write" and "Help".

Figure 3.9 - Scale Units for Transducer Block

The screenshot shows the same software interface as Figure 3.9, but with different settings. The navigation tabs and title are the same. The settings are as follows:

- Scale of Pressure Value:** This section contains three input fields: "Lower [EU(0%)]" with the value "0,000", "Upper [EU(100%)]" with the value "5080,000", and "Unit (EU)" with a dropdown menu set to "mmH2O (68°F)".
- Scale of Output Value:** This section also contains three input fields: "Lower [EU(0%)]" with the value "0,000", "Upper [EU(100%)]" with the value "5080,000", and "Unit (EU)" with a dropdown menu set to "mmH2O (68°F)".
- Temperature Unit:** The dropdown menu is set to "°C".

At the bottom right of the screen, there are two buttons: "Write" and "Help".

Figure 3.10 - Transducer Configuration Screen

Channel	Input (X)	Output (Y)
X01	0,000	0,000
X02	5,000	5,000
X03	10,000	10,000
X04	15,000	15,000
X05	20,000	20,000
X06	25,000	25,000
X07	30,000	30,000
X08	35,000	35,000
X09	40,000	40,000
X10	45,000	45,000
X11	50,000	50,000
X12	55,000	55,000
X13	60,000	60,000
X14	65,000	65,000
X15	70,000	70,000
X16	75,000	75,000
X17	80,000	80,000
X18	85,000	85,000
X19	90,000	90,000
X20	95,000	95,000
X21	100,000	100,000

Figure 3.11 - Transducer Configuration – User Table Screen

How to Configure the Analog Input Block



The Analog Input block takes the input data from the Transducer block, selected by channel number, and makes it available to other function blocks at its output. The transducer block provides the input unit of the Analog Input, and when the unit is changed in the transducer, the PV_SCALE unit is changed too. Optionally, a filter may be applied in the process value signal, whose time constant is PV_FTIME. Considering a step change to the input, this is the time in seconds to the PV reaches 63.2 % of the final value. If the PV_FTIME value is zero, the filter is disabled. For more details, please, see the Function Blocks Specifications.

To configure the Analog Input Block in offline mode, please, go to the main menu and select "Device Offline Configuration - Analog Input Block. Using this window, the user can configure the block mode operation, selects the channel, scales and unit for input and output value and the damping.

The user can set the block mode operation.

The user can select PV (Primary Value), Sec Value 1 (Secondary Value 1) or Sec Value 2 (Secondary Value 2) for the channel.

Scale of input value. The unit comes from the transducer block.

Scales and unit for the output value.

The user can set the PV damping value.

Offline Configuration - Analog Input

Basic Settings | Advanced Settings | Batch Info

Select Block Mode

Target: AUTO Write

Select Input

Channel: PV Write

Set Scale of Input Value

Upper [EU(100%)] 5080 mmH2O (68°F) Write

Lower [EU(0%)] 0 mmH2O (68°F)

Set Scale of Output Value

Upper [EU(100%)] 5080 Write

Lower [EU(0%)] 0

Unit: mmH2O (68°F)

Set PV Damping Value

Damping: 0 s Write

OK Cancel Help

Figure 3.12 – Basic Settings for Analog Input Block

Selecting the window "Advanced Settings", the user can configure the conditions for alarms and warnings, as well the fail safe condition. Please, see the window:

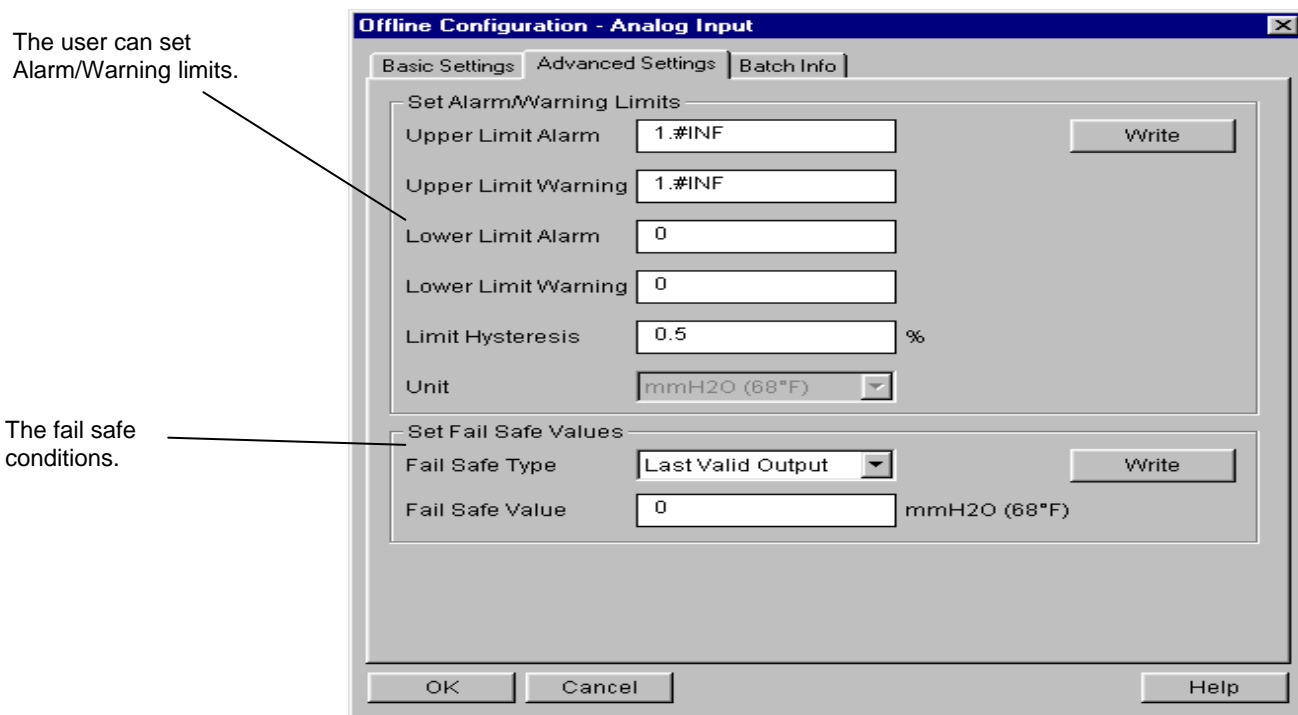

Figure 3.13 – Advanced Settings for Analog Input Block

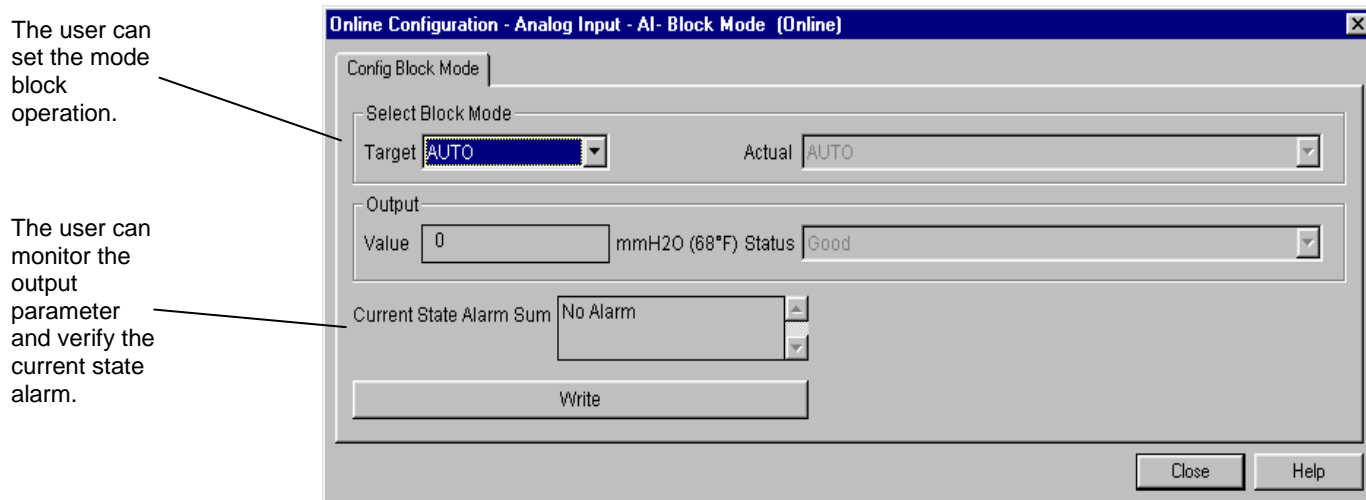

Figure 3.14 – Configuration for Analog Input Block

See the Analog Input Block configuration screens below using the Profibus View.

Basic Settings | **Advanced Settings** | Config Block Mode

Analog Input Block

Target: Channel:

Scale of Input Value

Upper [EU(100%)]
 Lower [EU(0%)]
 Unit:

Scale of Output Value

Upper [EU(100%)]
 Lower [EU(0%)]
 Unit:

Damping Value

Damping s

Figure 3.15 - Basic Settings for Analog Input Block

Basic Settings | **Advanced Settings** | Config Block Mode

Analog Input Block

Alarm/Warning Limits

Upper Limit Alarm
 Upper Limit Warning
 Lower Limit Alarm
 Lower Limit Warning
 Limit Hysteresis %
 Unit:

Fail Safe Values

Fail Safe Type
 Fail Safe Value

Figure 3.16 - Advanced Settings for Analog Input Block

Basic Settings | Advanced Settings | **Config Block Mode**

Analog Input Block

Block Mode

Target: Actual:

Output

Value: mmH2O (68°F)

Status:

Current Alarm Sum:

Figure 3.17 - Configuration for Analog Input Block

How to configure the Totalizer Block

The Totalizer function block takes the input data from the Transducer block, selected by channel number, and integrates over the time. This block is normally used to totalize flow, giving total mass or volume over a certain time, or totalize power, giving the total energy.

The Totalizer Function Block integrates a variable (e.g. flow rate or power) in function of the time to the corresponding quantity (e.g., volume, mass or distance). The rate unit of the Totalizer is providing by the transducer block. Internally, the time units are converted in rate units per second. Each rate, multiplied by the block execution time, gives the mass, volume or energy increment per block execution.

The TOTAL is the totalized quantity. The engineering unit used in the output is the UNIT_TOT. The unit of the output must be compatible with the unit of the input provided by the transducer by the channel. Then, if the input the rate is mass flow (like Kg/s, g/min, ton/h) the unit of the output must be mass (like kg, g, ton, lb, etc.).

For more details, please, see the Function Blocks Specifications.

To configure the Totalizer Block, please, go to the main menu and select Configuration - Totalizer Block. In this block, the user can configure the block mode operation, selects the channel, Totalizer mode and unit for the total:

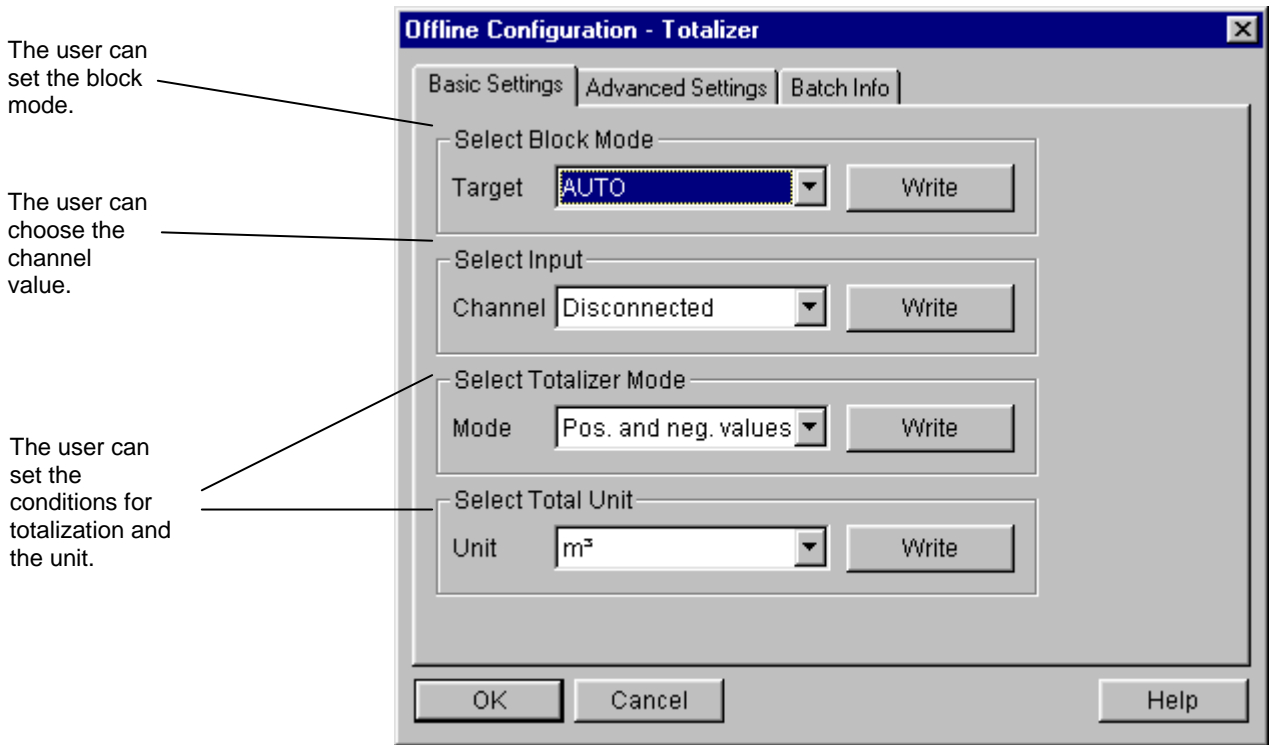

Figure 3.18 – Basic Settings for Totalizer Block

Choosing the "Advanced Settings" window, the user can set alarm and warning limits, as well the fail-safe condition:

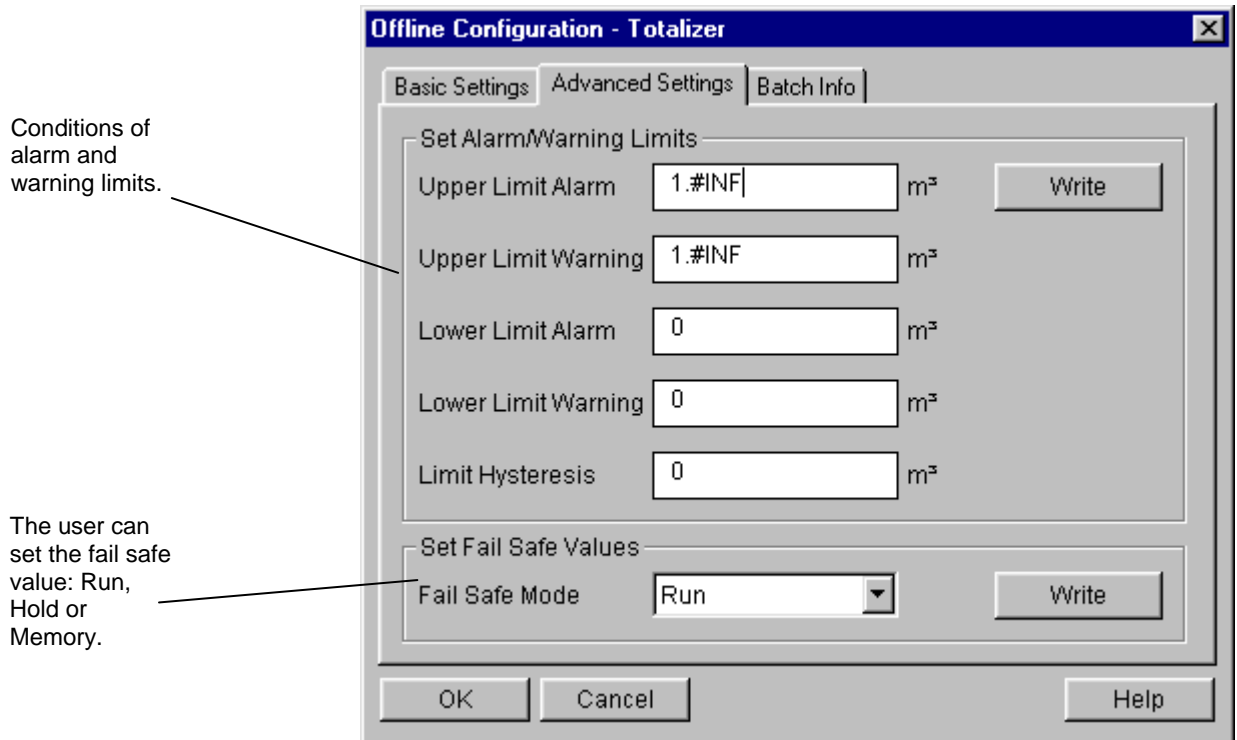

Figure 3.19 – Advanced Settings for Totalizer Block

The user can set the mode block operation.

The user can monitor the totalizer output parameter and verify the current state alarm.

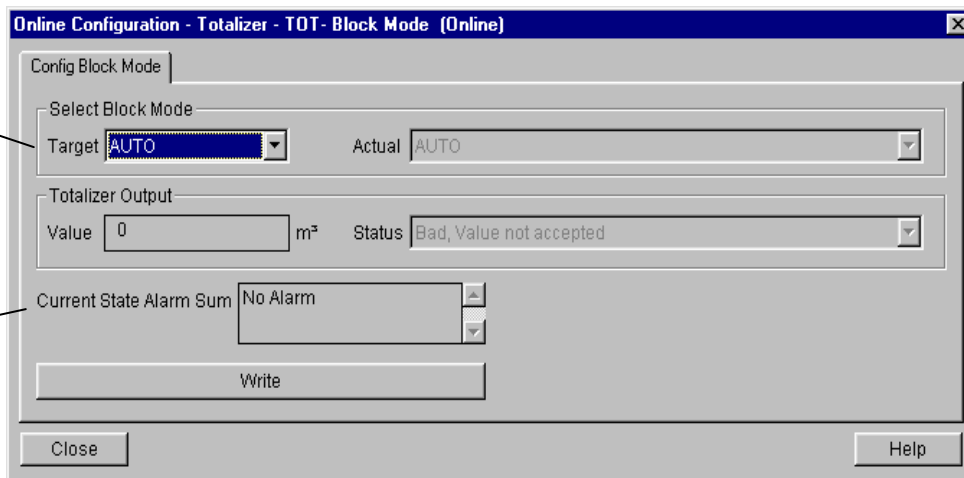

Figure 3.20 - Block Mode for Totalizer Block

The user can select: Totalize, Reset and Preset and enter the value for preset operation.

The user can monitor the totalizer output.

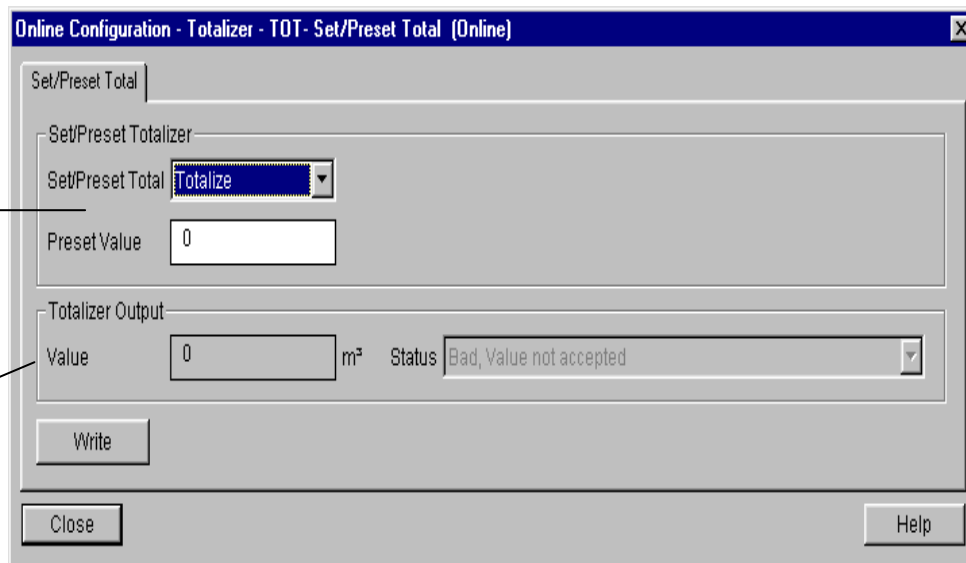



Figure 3.21 – Set / Reset for Totalizer Block

See the Totalizer Block configuration screens below using the Profibus View.

Basic Settings | Advanced Settings | Config Block Mode

Totalizer Block



Block Mode
Target:

Input
Channel:

Totalizer Mode
Mode:

Total Unit
Unit:

Figure 3.22 - Basic Settings for Totalizer Block

Basic Settings | Advanced Settings | Config Block Mode

Totalizer Block



Alarm/Warning Limits

Upper Limit Alarm	<input type="text" value="100"/>
Upper Limit Warning	<input type="text" value="100"/>
Lower Limit Alarm	<input type="text" value="0"/>
Lower Limit Warning	<input type="text" value="0"/>
Limit Hysteresis	<input type="text" value="0,000"/>

Fail Safe Values

Fail Safe Type:

Figure 3.23 - Advanced Settings for Totalizer Block

Basic Settings | Advanced Settings | **Config Block Mode**

Totalizer Block



Block Mode

Target Actual

Output

Value m²

Status

Current Alarm Sum

Figure 3.24 - Block Mode for Totalizer Block

Totalizer Block



Set/Preset Totalizer

Set/Preset Total

Preset Value

Totalizer Output

Value m²

Status

Figure 3.25 – Set / Reset for Totalizer Block

Lower and Upper Trim

NOTE

The calibration screens of lower and upper value of the Profibus View are similar to Simatic PDM screens.

Each sensor has a characteristic curve that establishes a relation between the applied pressure and the sensor signal. This curve is determined for each sensor and it is stored in a memory together with the sensor. When the sensor is connected to the transmitter circuit, the content of its memory is made available to the microprocessor.

Sometimes the value on the transmitter display and transducer block reading may not match the applied pressure.

The reasons may be:

- The transmitter mounting position.
- The user's pressure standard differs from the factory standard.
- The transmitter had its original characterization shifted by over pressurization, over heating or by long term drift.

The **TRIM** is used to match the reading with the applied pressure.

There are two types of trim available:

Lower Trim: It is used to trim the reading at the lower range. The operator informs the **LD303** the correct reading for the applied pressure. The most common discrepancy is the lower reading.

NOTE

Check on section 1 the note on the influence of the mounting position on the indicator.

For better accuracy, the trim adjustment should be made in the in the lower and upper values of the operation range values.

Upper Trim: It is used to trim the reading at the upper range. The operator informs the correct reading to **LD303** for the applied pressure.

For best accuracy, trim should be done at the operating range. The figures 3.26 to 3.29 show the trim adjustment operation.

Pressure Trim - LD303

NOTE

The calibration screens Pressure Trim of the Profibus View are similar to Simatic PDM screens.



Via Simatic PDM

It is possible to calibrate the transmitter by means of parameters CAL_POINT_LO and CAL_POINT_HI.

First of all, a convenient engineering unit should be chosen before starting the calibration. This engineering unit is configured by SENSOR_UNIT parameter. After its configuration the parameters related to calibration will be converted to this unit. Then, select Zero/Lower or Upper calibration menu.

The parameter `SENSOR_UNIT` should be configured according to the Engineering Unit wished for calibrating the device.

After the selection, this key should be pressed to complete the operation

The Engineering Units can be chosen from the Sensor Units list box.

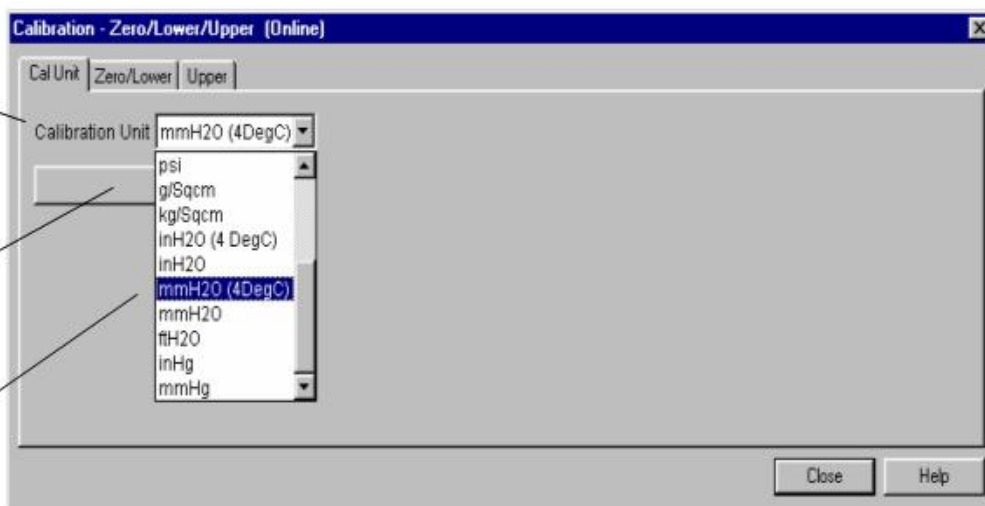

Figure 3.26 – Transducer Configuration Screen

The following engineering unit's codes are defined for pressure according to Profibus PA standard:

UNIT	CODES
inH ₂ O a 68 °F	1148
inHg a 0 °C	1156
ftH ₂ O a 68 °F	1154
mmH ₂ O a 68 °F	1151
mmHg a 0 °C	1158
psi	1141
bar	1137
mbar	1138
g/cm ²	1144
k/cm ²	1145
Pa	1130
kPa	1133
torr	1139
atm	1140
Mpa	1132
inH ₂ O a 4 °C	1147
mmH ₂ O a 4 °C	1150

Table 3.3 – Engineering Unit's Code



`SENSOR_UNIT` allows the user to select different units for calibration purposes than the units defined by `SENSOR_RANGE`. The `SENSOR_HI_LIM` and `SENSOR_LO_LIM` parameters define the maximum and minimum values the sensor is capable of indicating, the engineering units used, and the decimal point.

Let's take the lower value as an example:

Apply to the input zero or the pressure lower value in an engineering unit, this being the same used in parameter `SENSOR_UNIT`, and wait until the readout of pressure stabilizes.

Write zero or the lower value in parameter `CAL_POINT_LO`. For each value written a calibration is performed at the desired point.

For this case, a sensor range 3 is used: The LRL is -25400 mmH2O or -1000 inH2O.

The Lower Calibration Point should be entered. This value must be inside of the Sensor range limits allowed for each type of sensor.

After the calibration, the user can see the result for this process.

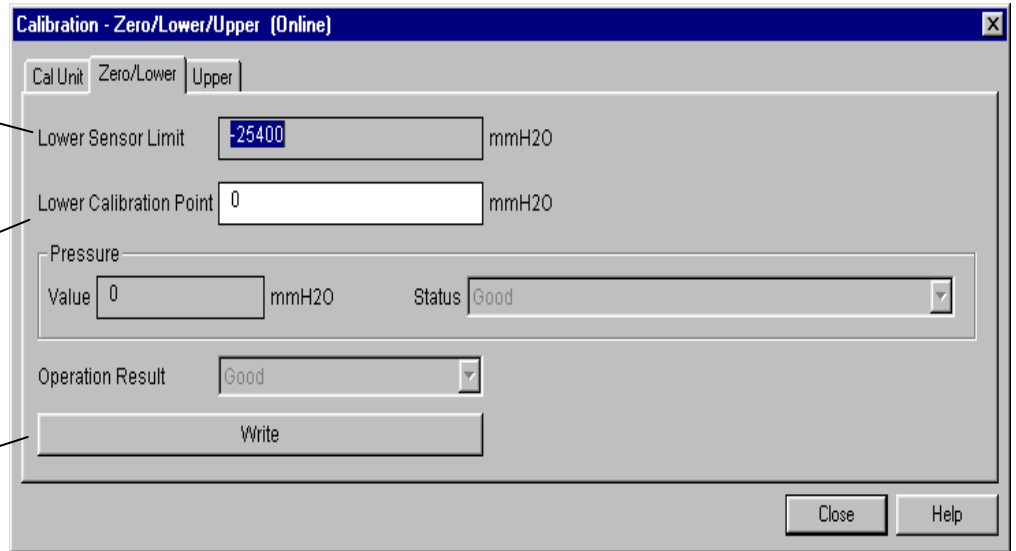

Figure 3.27 – Transducer Configuration Screen



Let's take the upper value as an example:

Apply to the input as the upper value a pressure of 25.400 mmH₂O and wait until the readout of pressure stabilizes. Then, write the upper value as, for example, 25.400 mmH₂O in parameter CAL_POINT_HI. For each value written a calibration is performed at the desired point.

For this case, a sensor range 3 is used: The URL is 25400 mmH2O or 1000 inH2O.

The Upper Calibration Point should be entered. This value must be inside of the Sensor range limits allowed for each type of sensor.

After the calibration, the user can see the result for this process.

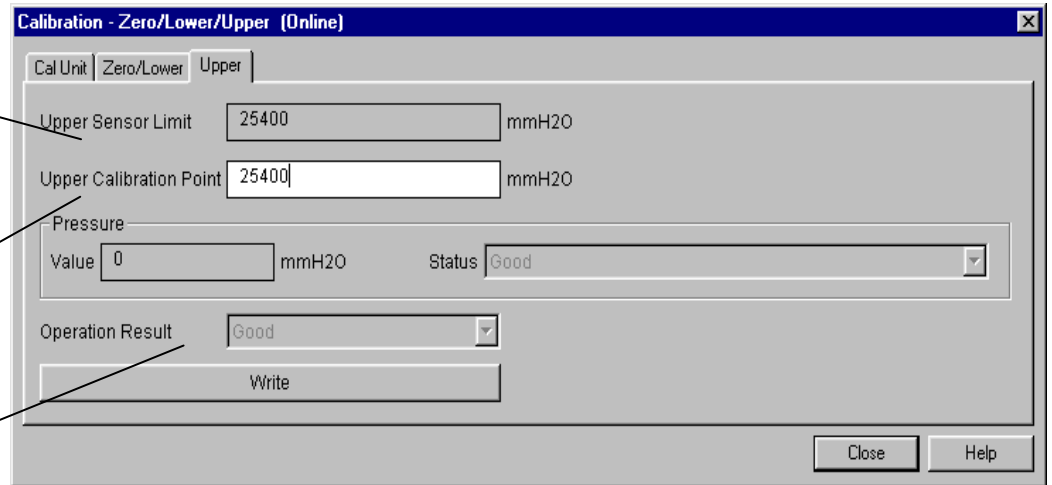

Figure 3.28 – Transducer Configuration Screen

WARNING

It is recommendable, for every new calibration, to save existing trim data, by means of parameter BACKUP_RESTORE, using option "Last Cal Backup".

Via Local Adjustment

In order to enter the local adjustment mode, place the magnetic tool in office "Z" until flag "MD" lights up in the display. Remove the magnetic tool from "Z" and place it in orifice "S". Remove and reinsert the magnetic tool in "S" until the message "LOC ADJ" is displayed. The message will be displayed during approximately 5 seconds after the user removes the magnetic tool from "S". Let's take the upper value as an example:

Apply to the input a pressure of 25.400 mmH₂O.

Wait until the pressure value stabilizes and then actuates parameter UPPER until it reads 25.400.

For the lower value the procedure is the same, but we need to actuate in the parameter LOWER.

NOTE

Trim mode exit via local adjustment occurs automatically should the magnetic tool not be used during some seconds.

Keep in that even when parameters LOWER or UPPER already present the desired value, they must be actuated so that calibration is performed.

Limit Conditions for Calibration:

For every writing operation in the transducer blocks there is an indication for the operation associate with the waiting method. These codes appear in parameter XD_ERROR. Every time a calibration is performed. Code 16, for example, indicates a successfully performed operation.

Upper:

$SENSOR_RANGE_EU0 < NEW_UPPER < SENSOR_RANGE_EU100 * 1.25$

Otherwise, XD_ERROR = 26.

$(NEW_UPPER - PRIMARY_VALUE) < SENSOR_RANGE_EU100 * 0.1$

Otherwise, XD_ERROR = 27.

$(NEW_UPPER - CAL_POINT_LO) > CAL_MIN_SPAN * 0,75$

Otherwise, XD_ERROR = 26.

NOTE

Codes for XD_ERROR:

- 16: Default Value Set;
- 22: Out of Range;
- 26: Invalid Calibration Request;
- 27: Excessive Correction.

Characterization Trim

NOTE

The calibration screens Characterization Trim of the Profibus View are similar to Simatic PDM screens.

It is used to correct the sensor reading in several points.

Use an accurate and stable pressure source, preferably a dead-weight tester, to guarantee the accuracy must be at least three times better than the transmitter accuracy. Wait for the pressure to stabilize before performing trim.

The sensor characteristic curve at a certain temperature and for certain ranges may be slightly nonlinear. This eventual non-linearity may be corrected through the Characterization Trim.

The user may characterize the transmitter throughout the operating range, obtaining even better accuracy.

The characterization is determined from two up to five points. Just apply the pressure and tell the transmitter the pressure that is being applied.

WARNING

The characterization trim changes the transmitter characteristics.

Read the instructions carefully and certify that a pressure standard with accuracy 0.03% or better is being used, otherwise the transmitter accuracy will be seriously affected.

Characterize a minimum of two points. These points will define the characterization curve. The maximum number of points is five. It is recommended to select the points equally distributed over the desired range or over a part of the range where more accuracy is required.

The Figure 3.29 shows the window of Simatic PDM to characterize a new curve. Note that FACTORY_CURVE_X indicates the applied pressure according to standard pressure source and FACTORY_CURVEX_Y indicates measured pressure value to **LD303**.

The number of points is configured in parameter FACTORY_CURVE_LENGTH, being in the maximum 5 points. The entry points will be configured in the FACTORY_CURVE_X and of output in the FACTORY_CURVE_Y.

The Parameter FACTORY_CURVE_BYPASS controls the enabling/disabling of the curve and has the following options:

- "Disable ",
- "Enable and Backup Cal ",
- "Disable and Restore Cal ",
- "Disable or Allows to enter the points"



To configure the points of the curve, the option "Disable or Allows to enter the points" must be chosen. Then press the "Characterization Cal". The following message appears: "This Function alters XMTR characteristics. Proceed? Y/N". To proceed, select "Yes". A new message appears: "Is XMTR connected to accurate pressure standard ?". To proceed, select "Yes". Apply the desired pressure and wait that the same one stabilizes. If the pressure is not stable, select "No-read again". If it is stable, enter "Yes" and then, type the applied pressure P1. Repeat this procedure for the next point P2. After that, if the user wants to configure more points, just repeat this procedure up to 5 points. If not, just select "No" for the question "Do you want to configure more points? ".

After configuring the points, the user needs to qualify the curve. The option "Enable and backup cal", enables the curve and save the calibration settings. The option "Disable and restore the cal", disables the curve and restores the calibration settings. The option "Disable", just disables the curve and does not take care about the calibration settings.

By the list box the user can enable or disable the Characterization Curve, enter the points, restore or backup the curve entered.

After choosing the condition for the curve, please, press this key to initiate the characterization curve method.

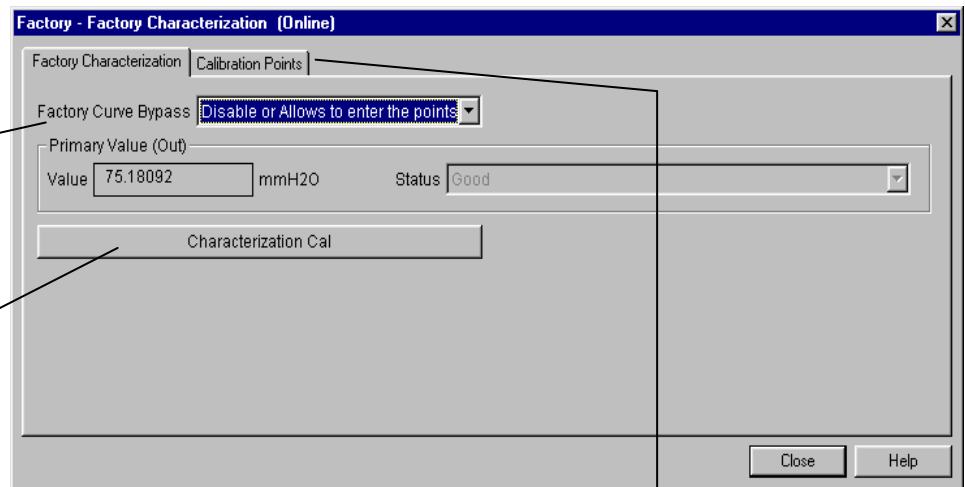

Select this page to see the configured points.

Figure 3.29 – The Characterization Curve Configuration

The Characterization Curve can have a minimum of 2 and up to 5 points. These points should be between the calibrated range for better results.

Sensor Information



The main information about the transmitter can be accessed selecting the Transducer block folder option as shown on the next figure. The sensor information will be displayed as shown below:

Sensor Construction Information.

Parameter	Value	Unit	Status
» Transducer			
» » Select Primary Value Type			
Primary Value type	Pressure		Loaded
» » Select Linearization Type			
Linearization type	No Linearisation.		Loaded
» » Set Scale of Pressure Value			
Lower [EU(0%)]	0	mmH2	Loaded
Upper [EU(100%)]	5080	mmH2	Loaded
» » Select Pressure Unit (EU)			
Pressure Unit (EU)	mmH2O		Loaded
» » Set Scale of Output Value			
Lower [EU(0%)]	0	mmH2	Loaded
Upper [EU(100%)]	5080	mmH2	Loaded
» » Select Output Unit			
Output Unit (EU)	mmH2O		Loaded
» » See Sensor Construction Info			
Sensor Type	Capacitance		Loaded
Sensor Range Code	Range 3 (1000 inH2O)		Loaded
Module Fill Fluid	Inert		Loaded
Isolator Material	Ox8		Loaded

Figure 3.30 – Transducer Block – Sensor Information

Some parameters are only factory configured (e.g. Sensor Type, Module Fill Fluid, etc.).

Temperature Trim

NOTE

The calibration screens Temperature Trim the Profibus View are similar to Simatic PDM screens.



Write in parameter CAL_TEMPERATURE any value in the range -40 °C to +85 °C. After that, check the calibration performance using parameter TEMPERATURE. The user can select the unit using the parameter TEMPERATURE_UNIT. Normally, its operation is done by a method in the factory.

The user can select the temperature unit.

Figure 3.31 – The Temperature Screen

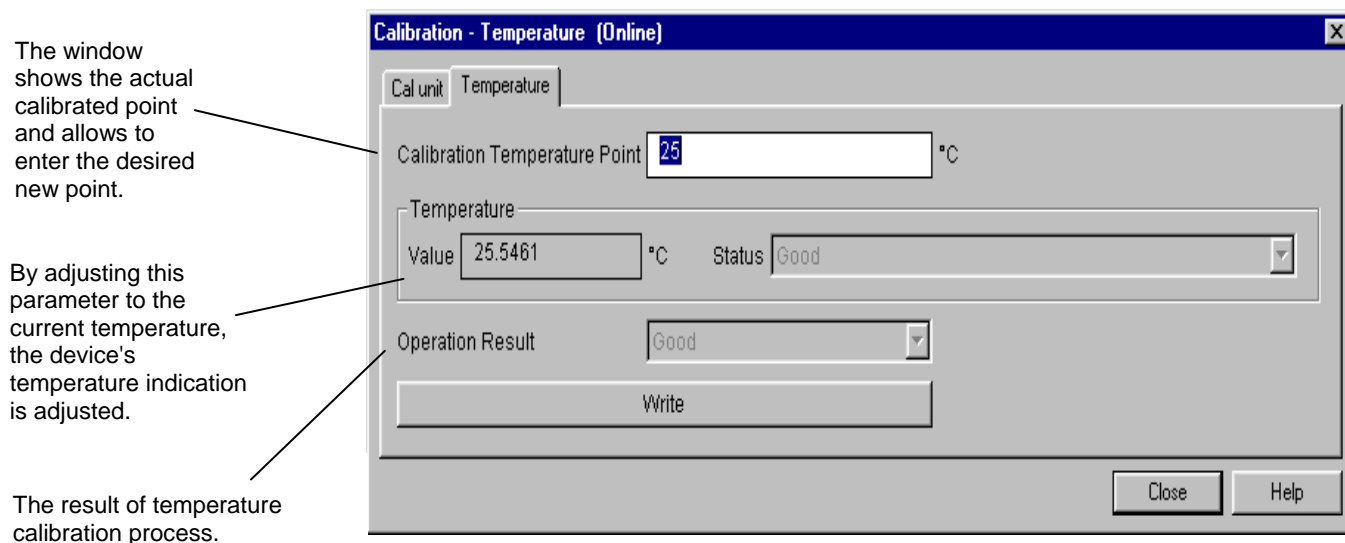

Figure 3.32 – The Temperature Trim Configuration Screen

Sensor Data Reading



All time that transmitter **LD303** is on, is verified if the serial number of the sensor in the sensor board is the same that the recorded serial number in EEPROM in the main board. When these numbers are different (a swap of sensor set or main board was carried through) the data stored in the EEPROM of sensor board is copied to the EEPROM of the main board.

Through the parameter **BACKUP_RESTORE**, also this reading can be made, choosing the option "Sensor Data Restore". The operation, in this case, is made independent of the sensor serial number. Through the option "Sensor Data Backup", the sensor data stored in the main board Eeprom memory can be saved in the EEPROM of the sensor board. (This operation is done at factory).

Through this parameter, we can recover default data from factory about sensor and last saved calibration settings, as well as making the rescue of calibrations. We have the following options:

- **Factory Cal Restore:** Recover last calibration settings made at factory;
- **Last Cal Restore:** Recover last calibration settings made by user and saved as backup;
- **Default Data Restore:** Restore all data as default;
- **Sensor Data Restore:** Restore sensor data saved in the sensor board and copy them to main board Eeprom memory;
- **Factory Cal Backup:** Copy the actual calibration settings to the factory ones;
- **Last Cal Backup:** Copy the actual calibration settings to the backup ones;
- **Sensor Data Backup:** Copy the sensor data at main board Eeprom memory to the Eeprom memory located at the sensor board;
- **None:** Default value, no action is done.

On the main menu, selecting "Device Factory - Backup/Restore", the user can select backup and restore operations:

NOTE

The backup setting screen of the Profibus View is similar to Simatic PDM screen.

This parameter is used to save or restore the default, factory or user configuration stored at the sensor module.

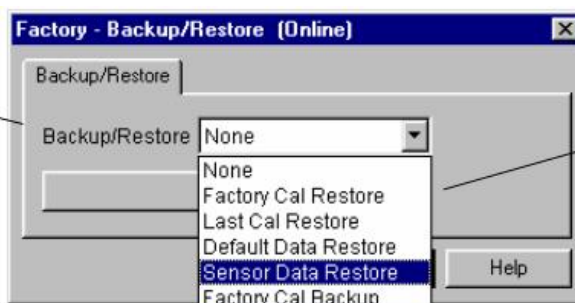

By selecting the options contained in the list box, operations of backup and restore data in the sensor module can be selected.

Figure 3.33 – Transducer Block – Backup/Restore

Transducer Display – Configuration

NOTE

The Transducer Display Configuration screen of the Profibus View is similar to Simatic PDM screen.

Using the Profibus View or Simatic PDM is possible to configure the Display Transducer block. As the name described it is a transducer due the interfacing of its block with the LCD hardware.

The Transducer Display is treated as a normal block by any configuration tool. It means, this block has some parameters and those ones can be configured according to customer's needs.

The customer can choose up to six parameters to be shown at LCD display they can be parameters just for monitoring purpose or for acting locally in the field devices by using a magnetic tool. The seventh parameter is used to access the physical device address. The user can change this address according to his application. To access and configure the Display Block, please, go to the main menu select "Device OnLine Configuration - Display Block":

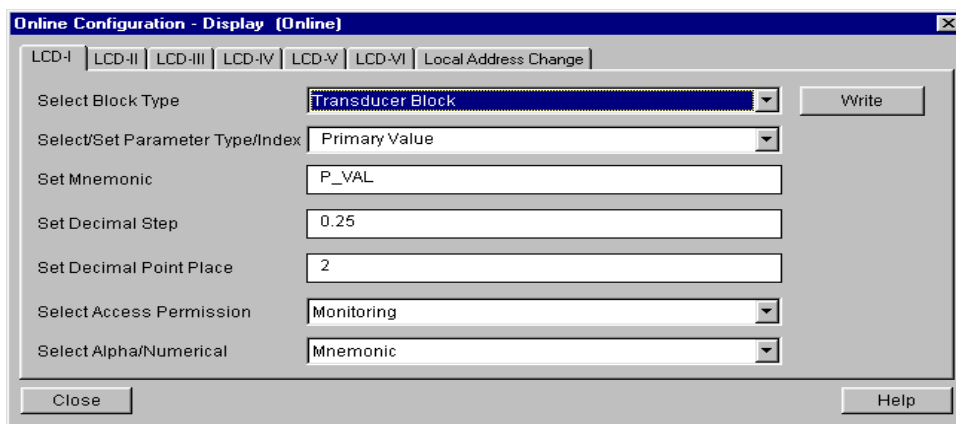

Figure 3.34 – Display Block

Display Transducer Block

The local adjustment is completely configured by Profibus View or Simatic PDM. It means, the user can select the best options to fit his application. From factory, it is configured with the options to set the Upper and Lower trim, for monitoring the input transducer output and check the Tag. Normally, the transmitter is much better configured by Profibus View or Simatic PDM, but the local functionality of the LCD permits an easy and fast action on certain parameters, since it does not rely on communication and network wiring connections. Among the possibilities by Local Adjustment, the following options can be emphasized: Mode block, Outputs monitoring, Tag visualization and Tuning Parameters setting.

The interface between the user is described very detailed on the "General Installation, Operation and Maintenance Procedures Manual". Please take a detailed look at this manual in the chapter related to "Programming Using Local Adjustment". It is significantly the resources on this transducer display, also all the Series 303 field devices from SMAR has the same methodology to handle with it. So, since the user has learned once, he is capable to handle all kind of field devices from SMAR.

All function block and transducers defined according Profibus PA have a description of their features written, by the Device Description Language.

This feature permits those third parties configuration tools enabled by Device Description Service technology can interpret these features and make them accessible to configure. The Function Blocks and Transducers of Series 303 have been defined rigorously according the Profibus PA specifications in order to be interoperable to other parties.

In order to able the local adjustment using the magnetic tool, it is necessary to previously prepare the parameters related with this operation via System Configuration.

There are six groups of parameters, which may be pre-configured by the user in order to able, a possible configuration by means of the local adjustment. As an example, let's suppose that you don't want to show some parameters; in this case, simply select "None" in the parameter, "Select Block Type". Doing this, the device will not take the parameters related (indexed) to its Block as a valid parameter.

Definition of Parameters and Values

Idx	Parameter	Data Type (length)	Valid Range/ Options	Default Value	Units	Store	Description
7	BLOCK_TAG_PARAM	Visible String			None	S	This is a tag of the block to which the parameter belongs to use up to a maximum of 32 characters.
8	INDEX_RELATIVE	Unsigned16	0-65535		None	S	This is the index related to the parameter to be actuated or viewed (1, 2...).
9	SUB_INDEX	Unsigned8	1-255		None	S	To visualize a certain tag, opt for the index relative equal to zero, and for the sub-index equal to one.
10	MNEMONIC	Visible String			None	S	This is the mnemonic for the parameter identification (maximum of 16 characters). Choose the mnemonic, preferably with no more than 5 characters because, this way, it will not necessary to rotate it on display.
11	INC_DEC	Float			None	S	It is the increment and decrement in decimal units when the parameter is Float or Float Status time, or integer, when the parameter is in whole units.
12	DECIMAL_POINT_NUMBER	Unsigned8	0-4		None	S	This is the number of digits after the decimal point (0 to 3 decimal digits)
13	ACCESS	Unsigned8	Monit/Action		None		The access allows the user to read, in the case of the "Monitoring" option, and to write when "action" option is selected, and then the display will show the increment and decrement arrows.
14	ALPHA_NUM	Unsigned8	Mnem/Value		None	S	These parameters include two options: value and mnemonic. In option value it is possible to display data both in the alphanumeric and in the numeric fields, this way, in the case of a data higher than 10000, it will be shown in the alphanumeric field.
63	DISPLAY_REFLESH	Unsigned8	1		None	D	

In option mnemonic, the display may show the data in the numeric field and the mnemonic in the alphanumeric field.

For devices where the software version is higher or equal to 1.10, please see the configuration of local adjustment using the local adjustment, in the Installation, operation and maintenance procedures manual.



In case you wish to visualize a certain tag, opt for the index relative equal to "tag". To configure other parameters just select "LCD-II" up to "LCD-VI" windows:

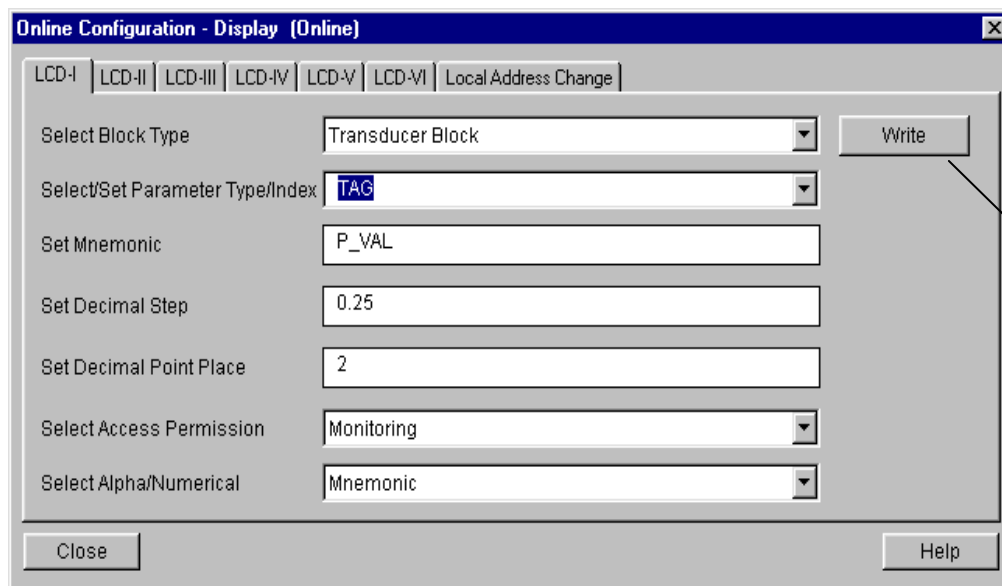

The option "Write" should be selected in order to execute the upgrade of local adjustment programming tree. After its step all the selected parameters will be shown on the LCD display.

Figure 3.35 – Parameters for Local Adjustment Configuration



The window "Local Address Change" allows the user "enable/disable" the access to changing the physical device address.

When the option "enable" is selected, the user can change the physical device address.

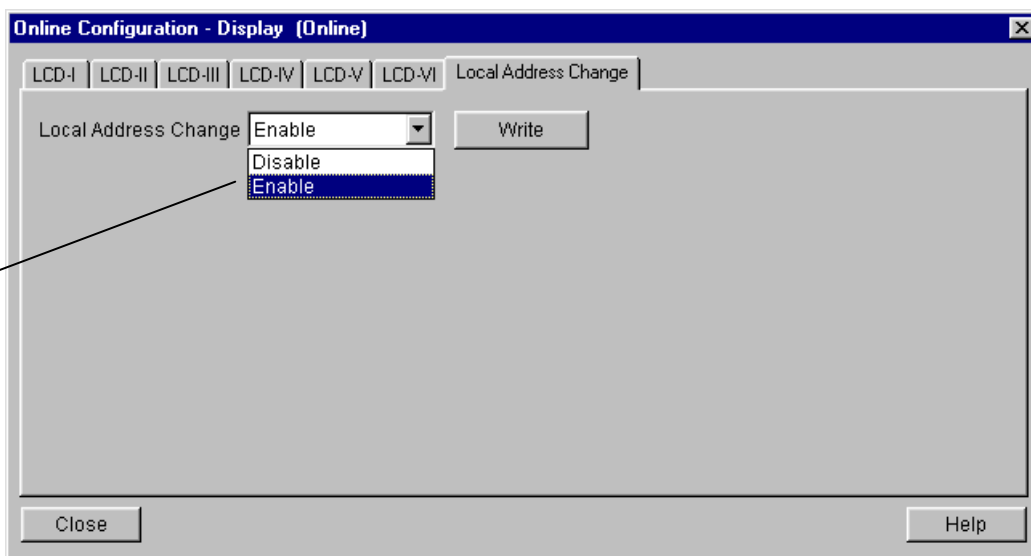

Figure 3.36 – Parameters for Local Adjustment Configuration

When the user enter into the local adjustment and rotate the parameters using the magnetic tool, after escaping to normal operation, e.g, the monitoring, if the parameter when the magnetic tool is removed has "Access Permission equal to "monitoring", then this last parameter will be shown at the LCD.

Always on the LCD interface will be shown two parameters at the same time, switching between the configured parameter at the LCD-II and the last monitoring parameter. If the user do not want to show two parameters at the same time, it is only necessary to opt for "none" when configure the LCD-II:

Selecting "None", only the last chosen monitoring parameter will be shown at LCD.

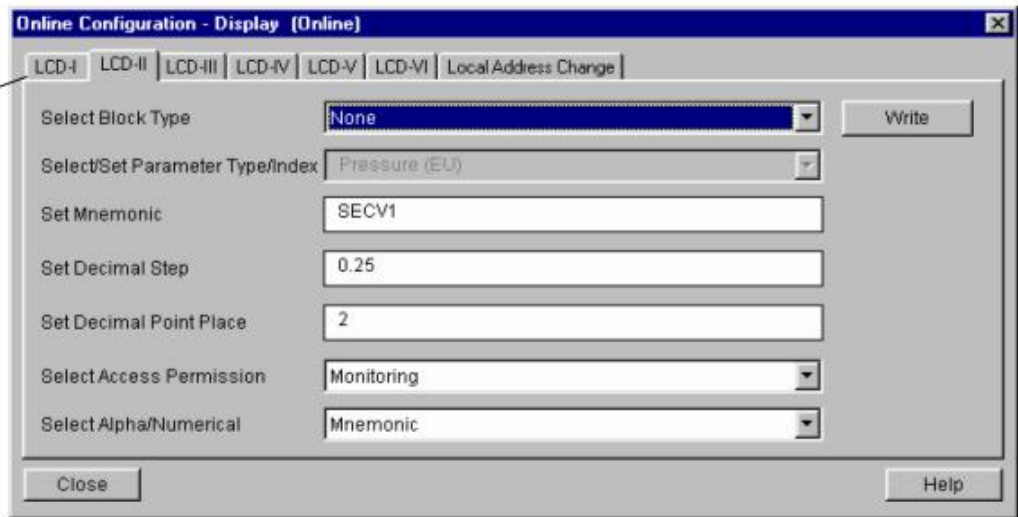

Figure 3.37 - Parameters for Local Adjustment Configuration

Local Adjustment Tree - Quick Guide

Local Adjustment tree – Quick Guide

1) HOW TO ACCESS LOCAL ADJUSTMENT TREE

- Follow Steps:**
- 1) Insert magnetic screw driver in zero hole;
 - 2) Wait 3 seconds;
 - 3) Insert magnetics screw driver in span hole;
 - 4) Wait 3 seconds, then MD will appear on display.

2) HOW TO BROWSE AND SELECT MENU OPTIONS

Browse: Insert magnetic screw driver in zero hole and hold.

Select: Insert magnetic screw driver in span hole and hold.

3) HOW TO CONFIGURE A BLOCK PARAMETER

- 1) Browse until CONF option, select LCD2;
- 2) Browse until BLOCK select the block that will be configured;
- 3) Browse until PRMT and set the relative index of the parameter;
- 4) Browse until ITEM and set the sub index (if applicable);
- 5) Browse until UPDT, insert magnetic screw driver in Zero Hole;
- 6) Reenter in Local Adjustment, browse until LCD2, now the parameter is available to change;
- 7) Repeat above steps for all the parameters to be configured.

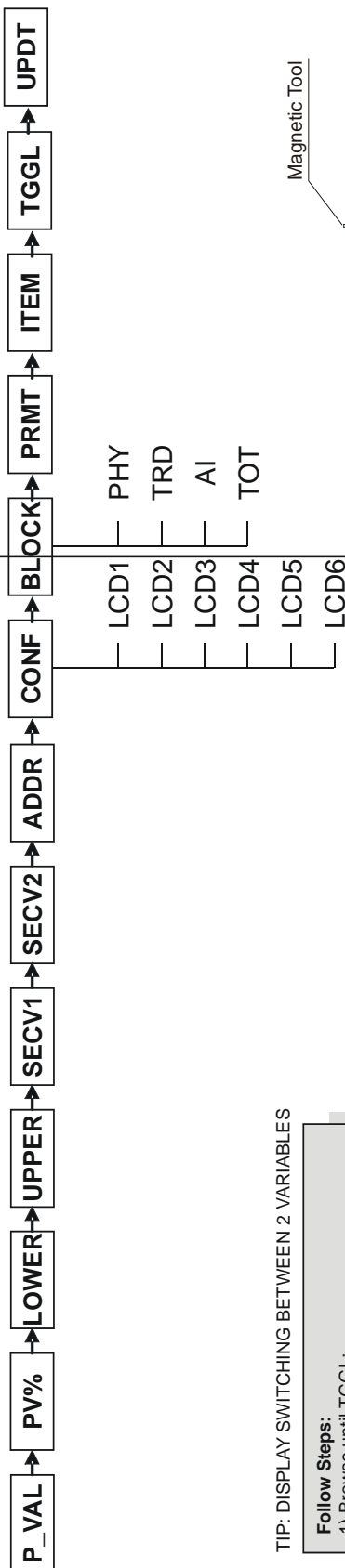

TIP: DISPLAY SWITCHING BETWEEN 2 VARIABLES

- Follow Steps:**
- 1) Browse until TGGL;
 - 2) Select 2;
 - 3) Configure LCD 2 with the desired parameter.

With TOGGLE 6

LCD1	LCD2	LCD3	LCD4	LCD5	LCD6
PVAL	SEC2	LOWER	UPPER	SEC1	SEC2
18	31	12	11	29	31

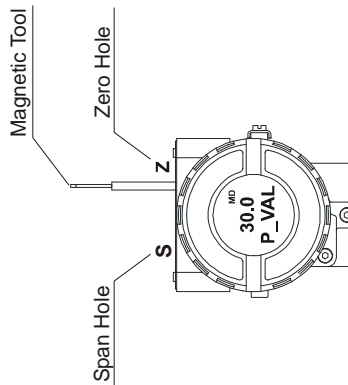

- CONF: option where it is possible to select the LCD to configure. Six options are available: from LCD1 up to LCD6;
- BLOCK: option where the user must select the function block that he desires to configure;
- PRMT: number correspondent to the relative index of the desired parameter into the chosen function block;
- ITEM: configure this option when a selected parameter has sub items to be configured, for example, the OUT_SCALE parameter is compounded by "EU at 100%", "EU at 0%", "Unit Index" and "Decimal Point";
- TGGL (Toggle): switches from 1 up to 6 configured parameters on the display. If TGGL is equal to 2, for example, the display will switch between LCD1 and LCD2;
- UPDT: refreshes the display when one of the LCDs are configured. Finalize display configuration by setting "UPDT", after choosing the configuration for the local adjustment.

The user can select the "Mode Block" parameter at the LCD. In this case is necessary to select the index equal to "Mode Block":

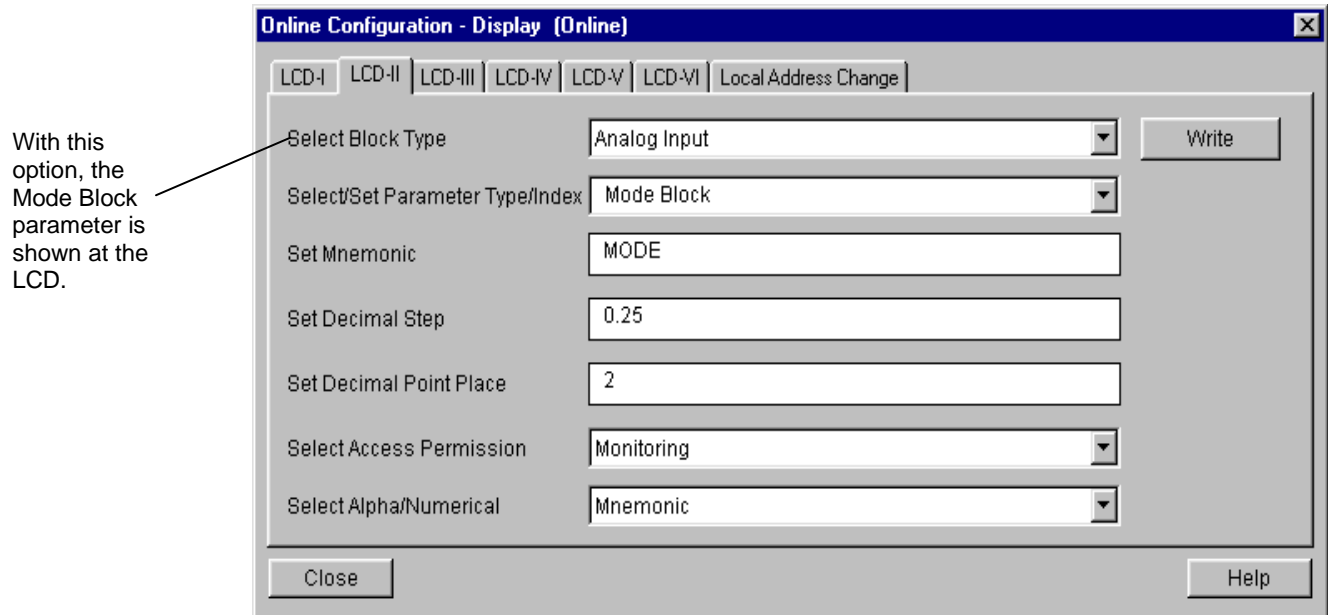

Figure 3.38 – Parameters for Local Adjustment Configuration

Programming Using Local Adjustment

The local adjustment is completely configured by Profibus View or Simatic PDM. It means, the user can select the best options to fit his application. From factory, it is configured with the options to set the Upper and Lower trim, for monitoring the input transducer output and check the Tag. Normally, the transmitter is much better configured by configuration tool, but the local functionality of the LCD permits an easy and fast action on certain parameters, since it does not rely on communication and network wiring connections. Among the possibilities by Local Adjustment, the following options can be emphasized: Mode block, Outputs monitoring, Tag visualization and Tuning Parameters setting.

The interface between the user is also described very detailed on the "General_Installation, Operation and Maintenance Procedures Manual". Please take a detailed look at this manual in the chapter related to "Programming Using Local Adjustment". It is significantly the resources on this transducer display, also all the Series 303 field devices from SMAR has the same methodology to handle with it. So, since the user has learned once, he is capable to handle all kind of field devices from SMAR. This Local adjustment configuration is a suggestion only. The user may choose his preferred configuration via configuration tool, simply configuring the display block.

The transmitter has two holes marked S and Z, right underneath the identification plate. They access two reed switches that can be activated by inserting the handle of the magnetic tool. This procedure enables the adjustment of the most important parameters of blocks. It also enables pre-configuration of the communication. See figure 3.39.

The table 3.5 describes what the actions in the S and Z holes cause in the **LD303** when the local adjustment is enable.

Without display the local adjustment is not possible.

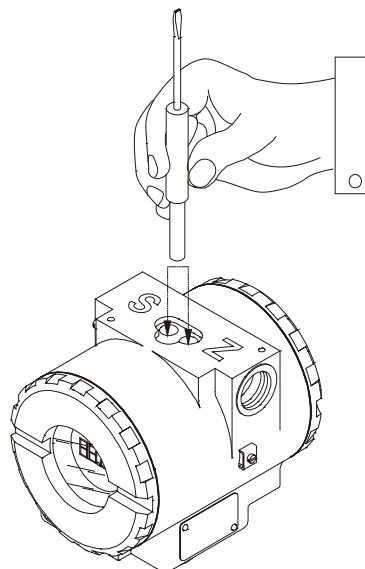

Figure 3.39 – Local Adjustment Holes

Action in	Cause
S	Starts and moves among the available functions.
Z	Selects the function showed in the indicator.

Table 3.5 – Purpose of the holes on the Housing

J1 Jumper Connection

If J1 jumper (see figure 3.40) is connected to the bolts under the word ON parameters could be simulated, through SIMULATE parameter, of the function blocks.

W1 Jumper Connection

If W1 jumper (see figure 3.40) is connected to the bolts under the word ON, the local adjustment programming tree is enabled and then important block parameters can be adjusted and communication can be pre-configured via local adjustment.

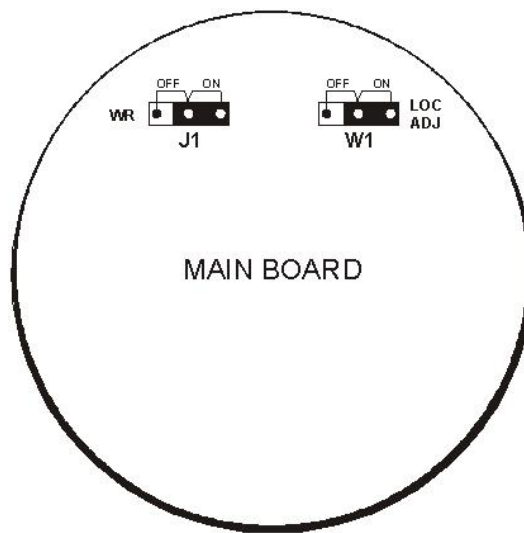
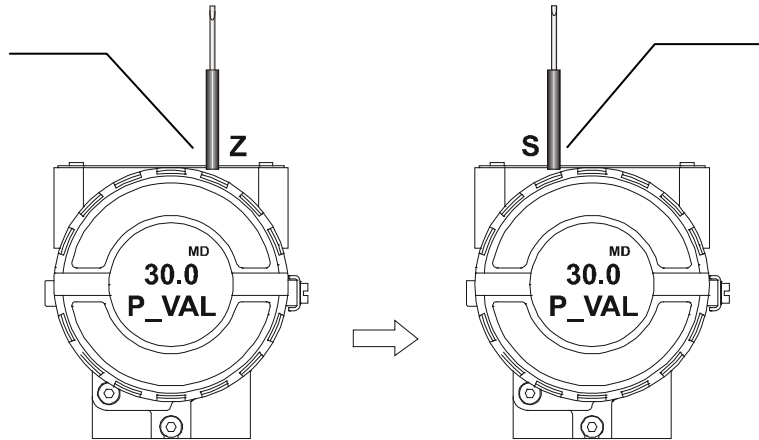

Figure 3.40 - J1 and W1 Jumpers

In order to start the local adjustment, place the magnetic tool in **Z** orifice and wait until letters **MD** are displayed.



Place the magnetic tool in **S** orifice and wait for 5 seconds.

Figure 3.41 - Step 1 - LD303

Remove the magnetic tool from **S** orifice.

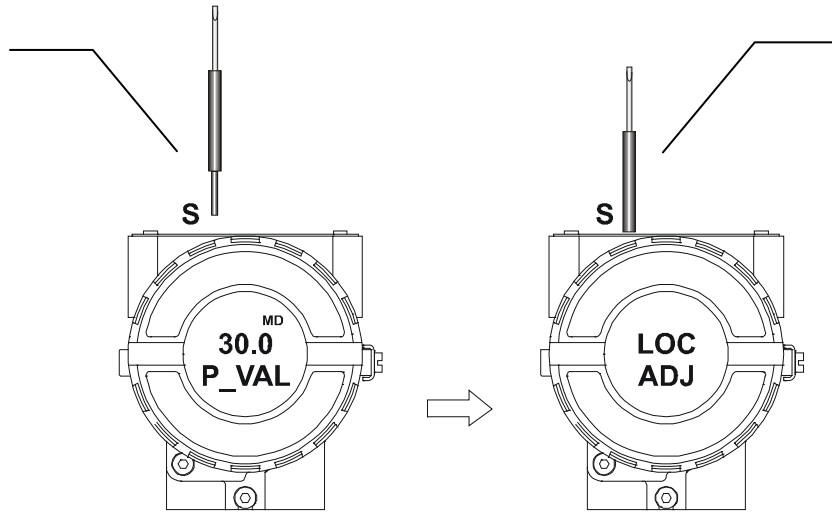

Insert the magnetic tool in **S** orifice once more and **LOC ADJ** should be displayed.

Figure 3.42 - Step 2 - LD303

Place the magnetic tool in **Z** orifice. If this is the first configuration, the option shown on the display is the **TAG** with its corresponding mnemonic configured by the configurator. Otherwise, the option shown on the display will be the one configured in the prior operation. By keeping the tool inserted in this orifice, the local adjustment menu will rotate.

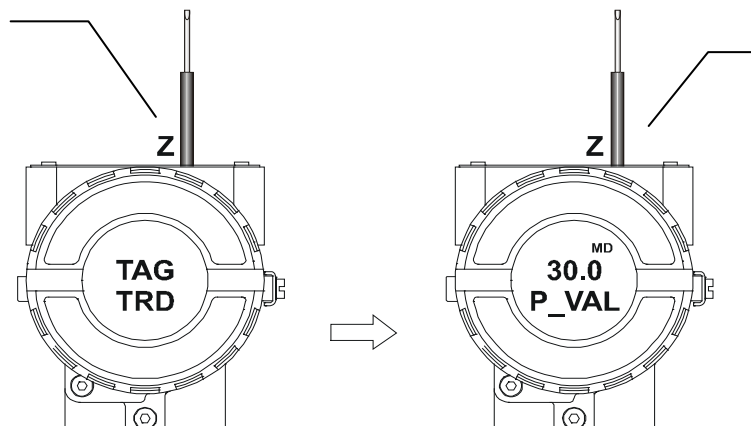

Suppose to be the first configuration. In this case, the option (**P_VAL**) is shown with its respective value. To change this value, insert the magnetic tool in **S** orifice, and keep it there until getting the desired value.

Figure 3.43 - Step 3 - LD303

In order to select the next function, the lower value (**LOWER**), move the magnetic tool from **S** to **Z** orifice. An arrow pointing upward (↑) increments the value and an arrow pointing downward (↓) decrements the value. In order to increment the value, insert and keep the tool in **S** orifice until getting the desired value.

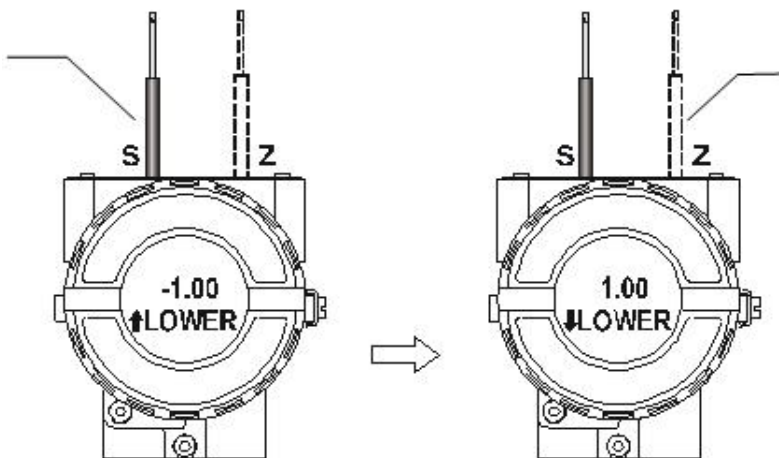

In order to decrement the lower value, place the magnetic tool in **Z** orifice to shift the arrow to the downward position. After that, insert and keep the tool in **S** until getting the desired value.

Figure 3.44 - Step 4 - LD303

In order to select the next function, the upper value (**UPPER**), move the magnetic tool from **S** to **Z** orifice. An arrow pointing upward (↑) increments the value and an arrow pointing downward (↓) decrements the value. In order to increment the value, insert and keep the tool in **S** orifice until getting the desired value.

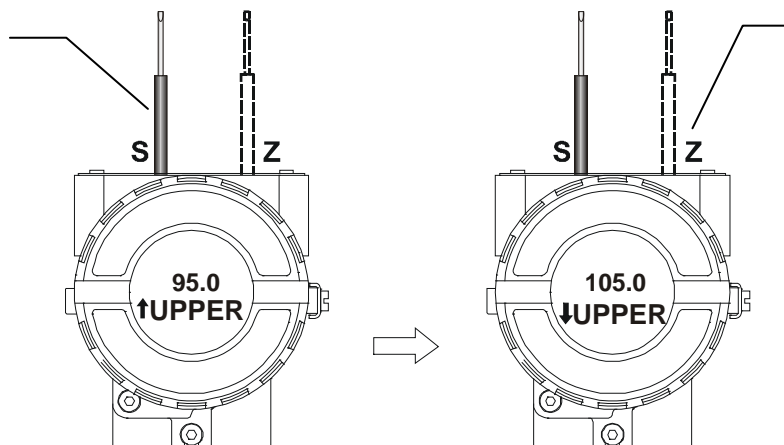

In order to decrement the upper value, place the magnetic tool in **Z** orifice to shift the arrow to the downward position. After that, insert and keep the tool in **S** orifice until getting the desired value.

Figure 3.45 - Step 5 - LD303

In order to select the next function, the address value (**ADDR**), move the magnetic tool from **S** to **Z** orifice. An arrow pointing upward (↑) increments the value and an arrow pointing downward (↓) decrements the value. In order to increment the value, insert and keep the tool in **S** orifice until getting the desired value.

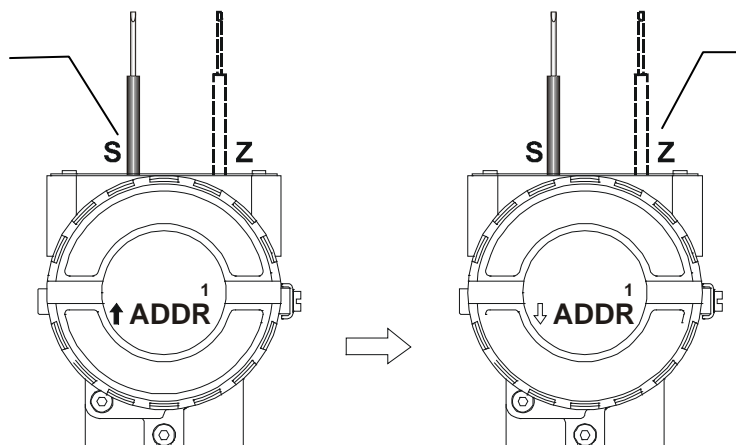

In order to decrement the address value, place the magnetic tool in **Z** orifice to shift the arrow to the downward position. After that, insert and keep the tool in **S** orifice until getting the desired value.

Figure 3.46 - Step 6 - LD303

Cyclical Diagnosis

Via cyclic communication is possible to verify diagnostics from the LD303 using the Profibus Master Class 1 or even via acyclic communication via Master Class 2. The Profibus-PA devices provide up to 4 standard diagnoses bytes via Physical Block (see figure 3.47 and 3.48) and when the most significant bit of the fourth Byte is "1", the diagnose will extend the information in more 6 bytes. These Diagnosis bytes can also be monitored via cyclic tools.

Len of status bytes 08 - Standard Diag 0E - Ext Diag	Status Type FE	Physical Block Slot 01	Status		Standard Diagnostic 4 bytes	Extended Diagnostic 6 bytes vendor specific
			Appears 01	Disappears 02		
From Physical Block						
When bit 55 (byte 4, MSB) is "1": the device has extended diagnostic						

Figure 3.47 – Cyclical Diagnosis

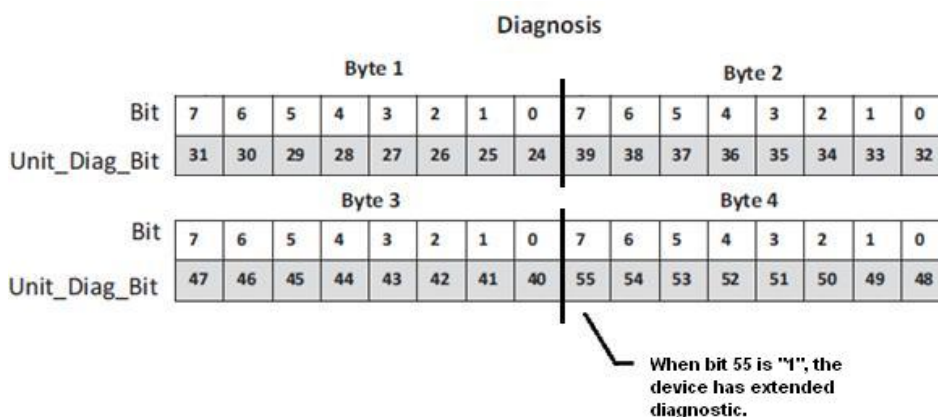

Figure 3.48 – Cyclic Diagnosis mapping for 4 bytes of Physical Block.

Unit_Diag_bit is described in the GSD file Profibus-PA device.

See below a description part of a GSD file for the 4 bytes and more detail:

```

;----- Description of device related diagnosis: -----
;
Unit_Diag_Bit(16) = "Error appears"
Unit_Diag_Bit(17) = "Error disappears"
;
;Byte 01
Unit_Diag_Bit(24) = "Hardware failure electronics"
Unit_Diag_Bit(25) = "Hardware failure mechanics"
Unit_Diag_Bit(26) = "Not used 26"
Unit_Diag_Bit(27) = "Electronic temperature alarm"
Unit_Diag_Bit(28) = "Memory error"
Unit_Diag_Bit(29) = "Measurement failure"
Unit_Diag_Bit(30) = "Device not initialized"
Unit_Diag_Bit(31) = "Device initialization failed"

;Byte 02
Unit_Diag_Bit(32) = "Not used 32"
Unit_Diag_Bit(33) = "Not used 33"
Unit_Diag_Bit(34) = "Configuration invalid"
Unit_Diag_Bit(35) = "Restart"
Unit_Diag_Bit(36) = "Coldstart"
    
```

Unit_Diag_Bit(37) = "Maintenance required"
 Unit_Diag_Bit(38) = "Characteristics invalid"
 Unit_Diag_Bit(39) = "Ident_Number violation"

;Byte 03

Unit_Diag_Bit(40) = "Not used 40"
 Unit_Diag_Bit(41) = "Not used 41"
 Unit_Diag_Bit(42) = "Not used 42"
 Unit_Diag_Bit(43) = "Not used 43"
 Unit_Diag_Bit(44) = "Not used 44"
 Unit_Diag_Bit(45) = "Not used 45"
 Unit_Diag_Bit(46) = "Not used 46"
 Unit_Diag_Bit(47) = "Not used 47"

;byte 04

Unit_Diag_Bit(48) = "Not used 48"
 Unit_Diag_Bit(49) = "Not used 49"
 Unit_Diag_Bit(50) = "Not used 50"
 Unit_Diag_Bit(51) = "Not used 51"
 Unit_Diag_Bit(52) = "Not used 52"
 Unit_Diag_Bit(53) = "Not used 53"
 Unit_Diag_Bit(54) = "Not used 54"
 Unit_Diag_Bit(55) = "Extension Available"

;Byte 05 TRD Block & PHY Block

Unit_Diag_Bit(56) = "Sensor failure"
 Unit_Diag_Bit(57) = "Temperature Out of work range"
 Unit_Diag_Bit(58) = "Pressure Sensor Out of High limit"
 Unit_Diag_Bit(59) = "Pressure Sensor Out of Low limit"
 Unit_Diag_Bit(60) = "Calibration Error - Check XD_ERROR parameter"
 Unit_Diag_Bit(61) = "Primary Value Unit not valid"
 Unit_Diag_Bit(62) = "No valid polynomial version"
 Unit_Diag_Bit(63) = "Device is writing lock"

;byte 06 AI Block

Unit_Diag_Bit(64) = "Simulation Active in AI Block"
 Unit_Diag_Bit(65) = "Fail Safe Active in AI Block"
 Unit_Diag_Bit(66) = "AI Block in Out of Service"
 Unit_Diag_Bit(67) = "AI Block Output out of High limit"
 Unit_Diag_Bit(68) = "AI Block Output out of Low limit"
 Unit_Diag_Bit(69) = "No assigned channel to AI Block"
 Unit_Diag_Bit(70) = "Not used 70"
 Unit_Diag_Bit(71) = "Not used 71"

;byte 07 TOT Block

Unit_Diag_Bit(72) = "TOT Block in Out of Service"
 Unit_Diag_Bit(73) = "Totalization Out of High limit"
 Unit_Diag_Bit(74) = "Totalization Out of Low limit"
 Unit_Diag_Bit(75) = "No assigned channel to TOT Block"
 Unit_Diag_Bit(76) = "Not used 76"
 Unit_Diag_Bit(77) = "Not used 77"
 Unit_Diag_Bit(78) = "Not used 78"
 Unit_Diag_Bit(79) = "Not used 79"

;byte 08

Unit_Diag_Bit(80) = "Not used 80"
 Unit_Diag_Bit(81) = "Not used 81"
 Unit_Diag_Bit(82) = "Not used 82"
 Unit_Diag_Bit(83) = "Not used 83"
 Unit_Diag_Bit(84) = "Not used 84"
 Unit_Diag_Bit(85) = "Not used 85"
 Unit_Diag_Bit(86) = "Not used 86"
 Unit_Diag_Bit(87) = "Not used 87"

```
;byte 09
Unit_Diag_Bit(88) = "Not used 88"
Unit_Diag_Bit(89) = "Not used 89"
Unit_Diag_Bit(90) = "Not used 90"
Unit_Diag_Bit(91) = "Not used 91"
Unit_Diag_Bit(92) = "Not used 92"
Unit_Diag_Bit(93) = "Not used 93"
Unit_Diag_Bit(94) = "Not used 94"
Unit_Diag_Bit(95) = "Not used 95"
```

```
;byte 10
Unit_Diag_Bit(96) = "Not used 96"
Unit_Diag_Bit(97) = "Not used 97"
Unit_Diag_Bit(98) = "Not used 98"
Unit_Diag_Bit(99) = "Not used 99"
Unit_Diag_Bit(100) = "Not used 100"
Unit_Diag_Bit(101) = "Not used 101"
Unit_Diag_Bit(102) = "Not used 102"
Unit_Diag_Bit(103) = "Not used 103"
```

NOTE

If the FIX flag is active on LCD, the **LD303** is configured to "Profile Specific" mode. When in "Manufacturer Specific" mode, the Identifier Number is 0x0895. Once the Identifier_Number_Selector is changed from "Profile Specific" to "Manufacturer Specific" or vice-versa, one must wait 5 seconds while is saved. Then, turn the **LD303** off and turn it on again. So, the Identifier Number is updated to the communication level. If the equipment is in "Profile Specific" and using the GSD file Identifier Number equals 0x0895, the acyclic communication will work with the tools based on EDDL, FDT/DTM, but no cyclic communication with the Profibus-DP master.

Section 4

MAINTENANCE PROCEDURES

General

NOTE
Equipments installed in hazardous atmospheres must be inspected in compliance with the IEC60079-17 standard.

SMAR Series 303 devices are extensively tested and inspected before delivery to the end user. Nevertheless, during their design and development, consideration was given to the possibility of repairs being made by the end user, if necessary.

In general, it is recommended that end users do not try repair printed circuit boards. Spare circuit boards may be ordered from **SMAR** whenever necessary. Refer to the item "Returning Materials" at the end of this Section.

SYMPTOM	PROBABLE SOURCE OF PROBLEM
NO COMMUNICATION	<ul style="list-style-type: none"> ▪ Transmitter Connections Check wiring polarity and continuity. Check for shorts or ground loops. Check if the power supply connector is connected to main board. Check if the shield is not used as a conductor. It should be grounded at one end only.
	<ul style="list-style-type: none"> ▪ Power Supply Check power supply output. The voltage must be between 9 - 32 VDC at the LD303 terminals. Noise and ripple should be within the following limits: a) 16 mV peak to peak from 7.8 to 39 KHz. b) 2 V peak to peak from 47 to 63 Hz for non-intrinsic safety applications and 0.2 V for intrinsic safety applications. c) 1.6 V peak to peak from 3.9 MHz to 125 MHz.
	<ul style="list-style-type: none"> ▪ Network Connection Check that the topology is correct and all devices are connected in parallel. Check that two Terminators are OK and correctly positioned. Check that the coupler connections are OK and correctly positioned. Check that the Terminators are according to the specifications. Check length of trunk and spurs. Check spacing between couplers.
	<ul style="list-style-type: none"> ▪ Network Configuration Make sure that device address is configured correctly.
	<ul style="list-style-type: none"> ▪ Electronic Circuit Failure Check the main board for defect by replacing it with a spare one.
INCORRECT READING	<ul style="list-style-type: none"> ▪ Transmitter Connections Check for intermittent short circuits, open circuits and grounding problems. Check if the sensor is correctly connected to the LD303 terminal block.
	<ul style="list-style-type: none"> ▪ Noise, Oscillation Adjust damping Check grounding of the transmitters housing. Check that the shielding of the wires between transmitter / panel is grounded only in one end.
	<ul style="list-style-type: none"> ▪ Sensor Check the sensor operation; it shall be within its characteristics. Check sensor type; it shall be the type and standard that the LD303 has been configured to. Check if process is within the range of the sensor and the LD303.

Table 4.1 - Messages of Errors and Potential Cause

If the problem is not presented in the table above follow the Note below:

NOTE
<p>The Factory Init should be tried as a last option to recover the equipment control when the equipment presents some problem related to the function blocks or the communication. This operation must only be carried out by authorized technical personnel and with the process offline, since the equipment will be configured with standard and factory data.</p> <p>This procedure resets all the configurations run on the equipment, after which a partial download should be performed. With exception to the equipment physical address and the GSD identifier number selector parameter. After doing this, all configurations must be remade according to their applications.</p> <p>Two magnetic tools should be used to this effect. On the equipment, withdraw the nut that fixes the identification tag on the top of the housing, so that access is gained to the "S" and "Z" holes.</p> <p>The operations to follow are:</p> <ol style="list-style-type: none">1) Switch off the equipment, insert the magnetic tools and keep them in the holes (the magnetic end in the holes);2) Feed the equipment;3) As soon as Factory Init is shown on the display, take off the tools and wait for the "5" symbol on the right upper corner of the display to unlit, thus indicating the end of the operation. <p>This procedure makes effective all the factory configuration and will eliminate eventual problems with the function blocks or with the equipment communication.</p> <p>Note that this procedure must be performed by authorized personal only and with the process switched off, since the equipment will be configured with standard and factory data.</p>

Disassembly Procedure

WARNING
Do not disassemble with power on.

The Figure 4.4 – Exploded View an exploded view of the transmitter and will help to visualize the following:

Sensor Cleaning

In order to have access to the sensor (19) for cleaning purposes, the transmitter should be removed from its process connections. The transmitter should be isolated from the process by means of manifolds or valves; then, the drain (13) must be opened to vent any remaining pressure.



Figure 4.1 - Sensor Safety Rotation

After this, the transmitter may be removed from the standpipe. The flange bolts (16) may now be loosened crosswise, one at a time. After removing bolts and flanges (15), the isolating diaphragms will be easily accessible for cleaning.

Cleaning should be done carefully in order to avoid damaging the delicate isolating diaphragms. Use of a soft cloth and a non-acid solution is recommended. The oscillating circuit is a part of the sensor and the replacement of one implies replacing the other.

To remove the sensor from the electronic housing, the electrical connections (in the field terminal side) and the main board connector must be disconnected.

Loosen the hex screw (20) and carefully unscrew the electronic housing from the sensor, observing that the flat cable is not excessively twisted.

WARNING

To avoid damage do not rotate the electronic housing more than 270° without disconnecting the electronic circuit from the sensor and from the power supply. See Figure 4.1.

Electronic Circuit

To remove the circuit board (5), loosen the two screws (3) that anchor the board.

WARNING

The board has CMOS components, which may be damaged by electrostatic discharges. Observe correct procedures for handling CMOS components. It is also recommended to store the circuit boards in electrostatic-proof cases.

Pull the main board out of the housing and disconnect the power supply and the sensor connectors.

Reassemble Procedure

WARNING

Do not assemble the main board with power on.

Sensor Mounting

When mounting the sensor (19), it is recommended to make use of a new set of gaskets (18 & 24) compatible with the process fluid. The bolts, nuts, flanges and other parts should be inspected for corrosion or other eventual damage. Damaged parts should be replaced.

NOTE

Backup Rings

High pressure transmitters A5, M5, M6 and High static pressure transmitters H2, H3, H4, H5 and the sensors with tantalum diaphragm that use Buna-N or Viton O'Ring must use a metallic backup Ring (17) to prevent extrusion of O'Ring. Do not use the backup O'Ring when the flange has an insert of Kynar (PVDF).

Avoid bending the backup ring and inspect it for knots, cuts etc. Be careful when mounting it. The flat side, which shines more than the bevelled side should be mounted against the O'Ring. (See Figure 4.2 - Backup Ring Mounting).

Gaskets should be lightly lubricated with silicone oil before they are fitted into their recesses. Use halogen grease for inert fill applications. The flanges should then be positioned in order to press them in place. With the flanges holding the O-Rings in place, insert the four bolts (16) and tighten the nuts (23) finger tight, making sure the flanges remain parallel all the time.

- Tighten one nut till the flange seats.
- Tighten the nut diagonally across with a torque of 2.75 ±0.25 kgf.m.
- Tighten the first nut with the same torque.
- Verify the flange alignment.
- Check torque on the four bolts.

If adapters (25) have been removed, it is recommended to replace gaskets (24) and to connect the adapters to the process flanges before coupling them to the sensor. Optimum torque is 2.75 ±0.25 Kgf.m.

The fitting of the sensor must be done with the main board out of the electronic housing. Mount the sensor to the housing turning clockwise until it stops. Then turn it counterclockwise until it faces the protective cover (1) parallel to the process flange. Tighten the hex screw (20) to lock the housing to the sensor.

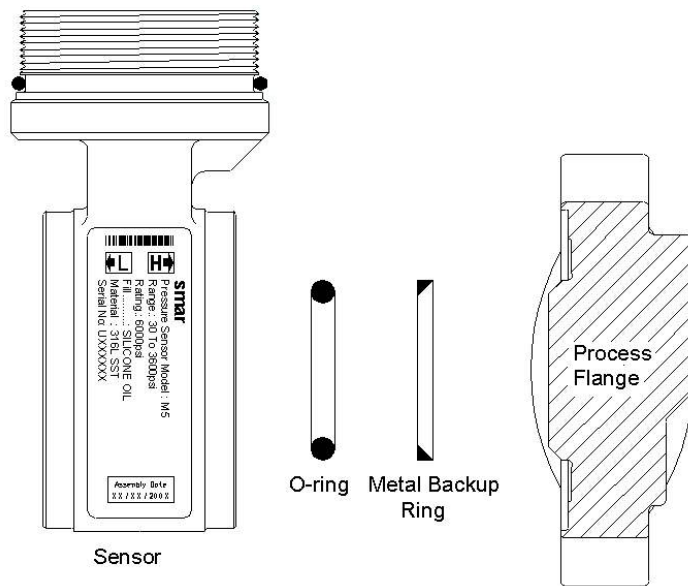

Figure 4.2 - Backup Ring Mounting

Electronic Circuit

Plug sensor connector and power supply connector to main board.

Attach the display to the main board. Observe the four possible mounting positions. (Figure 4.3 - Four Possible Positions of the Display). The **SMAR** mark indicates up position.

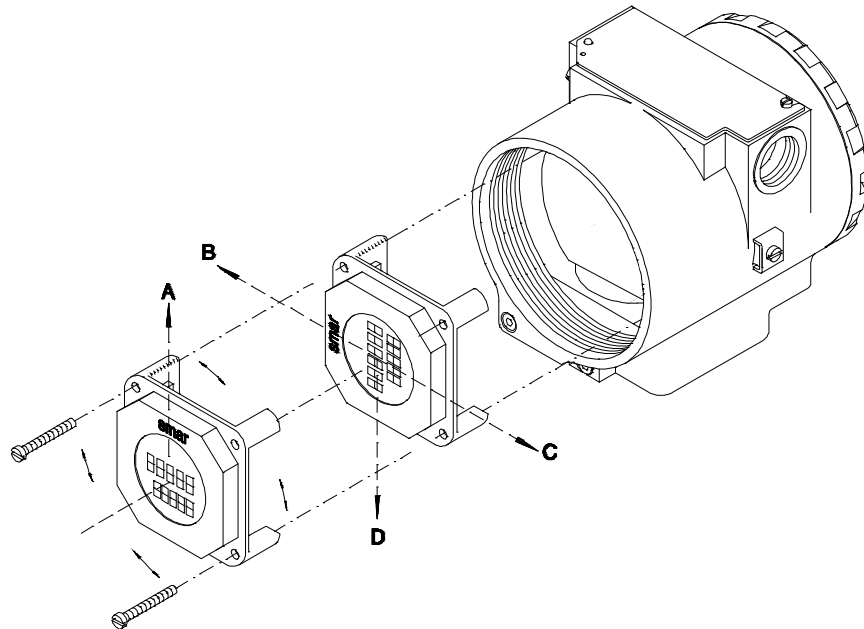

Figure 4.3 - Four Possible Positions of the Display

Anchor the main board and display with their screws (3).

After tightening the protective cover (1), mounting procedure is complete. The transmitter is ready to be energized and tested. It is recommended to open the transmitter's pressure taps to atmosphere and adjust the TRIM.

Interchangeability

In order to obtain an accurate and better temperature compensated response. Each sensor is submitted to a characterization process and the specific data is stored in an EEPROM located in the sensor body.

Every time the power is turned on, the main circuit reads the sensor serial number, should it differ from the number stored in the memory. The circuit understands that there is a new sensor and the following information is transferred from the sensor to the main circuit.

- Temperature compensation coefficients;
- Sensor's trim, including 5-point characterization curve;
- Sensor characteristics: type, range, diaphragm material and fill fluid.

The other transmitter characteristics are stored in the main circuit memory and are not affected by sensor change.

Upgrading LD301 to LD303

The sensor and casing of the LD301 is exactly the same as the **LD303**. By changing the circuit board of the LD301 it becomes a **LD303**. The display on LD301 version 5.XX is the same as on **LD303** and can therefore be used with the **LD303** upgrade circuit board. With a LD301 version three or earlier, that display can not be used.

Upgrading the LD301 to a **LD303** is therefore very much the same as the procedure for replacing the main board described above.

To remove the circuit board (5), loosen the two screws (3) that anchor the board.

Caution with the circuit boards must be taken as mentioned above.

Pull the LD301 main board out of the housing and disconnect the power supply and the sensor connectors.

Put in the **LD303** main board reversing the procedure for removing the LD301 circuit.

Returning Materials

Should it become necessary to return the transmitter and/or configurator to **SMAR**, simply contact our office, informing the defective instrument serial number, and return it to our factory.

If it becomes necessary to return the transmitter and/or configurator to Smar, simply contact our office, informing the defective instrument's serial number, and return it to our factory. In order to speed up analysis and solution of the problem, the defective item should be returned with the Service Request Form (SRF – Appendix B) properly filled with a description of the failure observed and with as much details as possible. Other information concerning to the instrument operation, such as service and process conditions, is also helpful.

Instruments returned or to be revised outside the guarantee term should be accompanied by a purchase order or a quote request.

ACCESSORIES	
ORDERING CODE	DESCRIPTION
SD1	Magnetic Tool for Local Adjustment
BC1	Profibus/RS232 Interface
PS302	Power Supply
FDI302	Field Device Interface
BT302	Terminator
DF47	Intrinsic Safety Barrier
DF48	Profibus Repeater

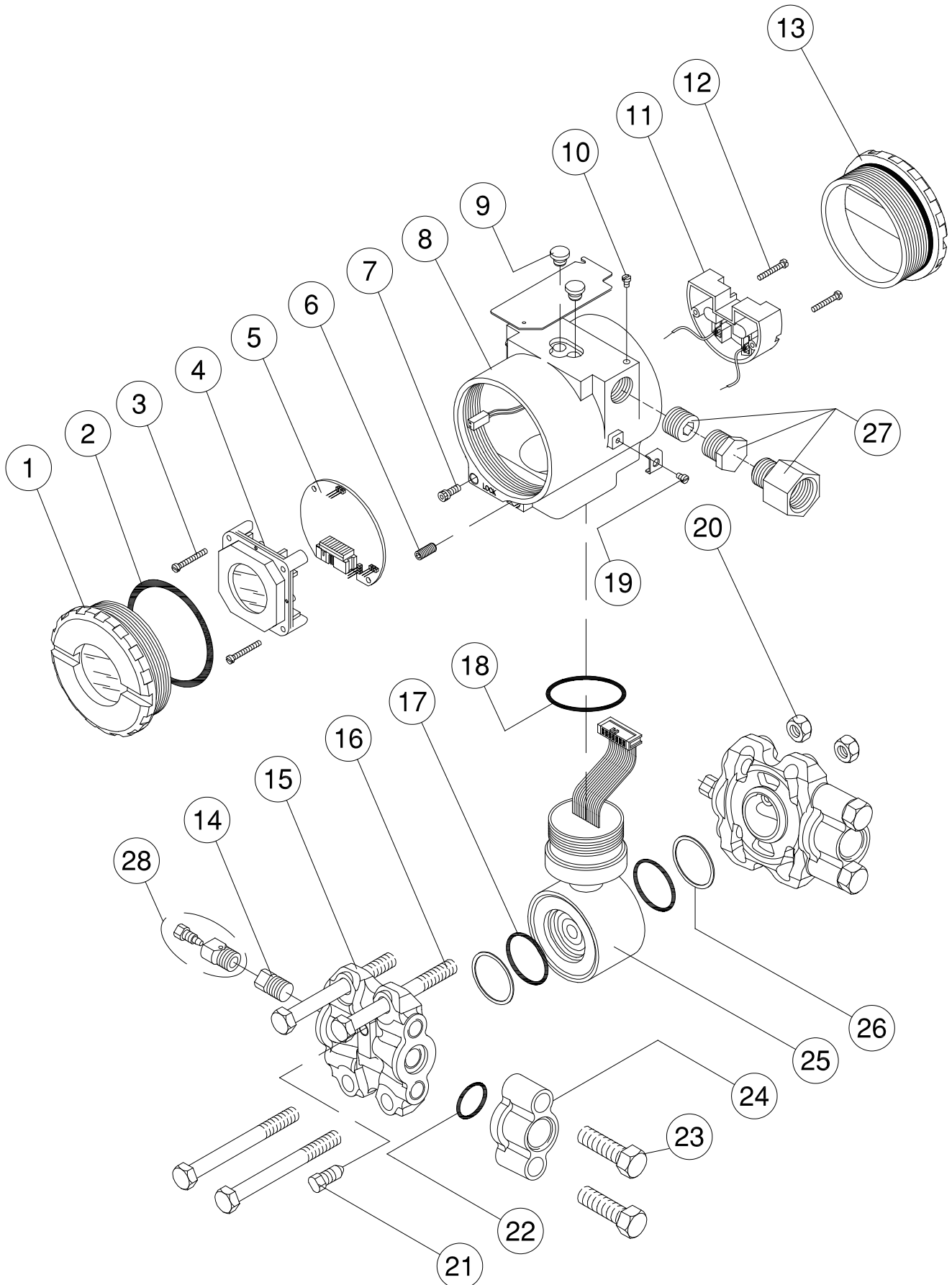

Figure 4.4 - Exploded View

SPARE PARTS LIST			
DESCRIPTION OF PARTS	POSITION	CODE	CATEGORY (NOTE 1)
HOUSING, Aluminum (NOTE 2)			
½ - 14 NPT	8	400-0291	
M20 x 1.5	8	400-0292	
PG 13.5 DIN	8	400-0293	
HOUSING, 316 SS (NOTE 2)			
½ - 14 NPT	8	400-0294	
M20 x 1.5	8	400-0295	
PG 13.5 DIN	8	400-0296	
COVER (INCLUDES O'RING)			
Aluminum	1 and 13	204-0102	
316 SS	1 and 13	204-0105	
COVER WITH WINDOW FOR INDICATION (INCLUDES O'RING)			
Aluminum	1	204-0103	
316 SS	1	204-0106	
COVER LOCKING SCREW			
	7	204-0120	
SENSOR LOCKING SCREW			
Without Head M6 Screw	7	400-1121	
EXTERNAL GROUND SCREW			
	22	204-0124	
IDENTIFICATION PLATE FIXING SCREW			
	10	204-0116	
DIGITAL INDICATOR			
	4	214-0108	
TERMINAL INSULATOR			
	11	400-0059	
MAIN ELECTRONIC CIRCUIT BOARD			
	5	400-0297	A
FLANGE (WITH HOLE FOR DRAIN/VENT)			
Plated Carbon Steel	15	204-0501	
Stainless Steel 316	15	204-0502	
Hastelloy C276	15	204-0503	
Monel 400	15	204-0504	
FLANGE (WITHOUT HOLE FOR DRAIN/VENT)			
Plated Carbon Steel	15	204-0511	
Stainless Steel 316	15	204-0512	
Hastelloy C276	15	204-0513	
Monel 400	15	204-0514	
BLANK FLANGE (FOR GAGE AND ABSOLUTE MODELS)			
Plated Carbon Steel	15	204-1101	
Stainless Steel 316	15	204-1102	
ADAPTER			
Plated Carbon Steel	24	203-0601	
Stainless Steel 316	24	203-0602	
Hastelloy C276	24	203-0603	
Monel 400	24	203-0604	
O'RINGS (NOTE 3)			
Cover, Buna-N	2	204-0122	B
Neck, Buna-N	21	204-0113	B

SPARE PARTS LIST			
DESCRIPTION OF PARTS	POSITION	CODE	CATEGORY (NOTE 1)
O'RINGS (NOTE 3)			
Flange, BUNA-N	17	203-0401	B
Flange, VITON	17	203-0402	B
Flange, TEFLON	17	203-0403	B
Flange, ETHYLENE/PROPYLENE	17	203-0404	B
Flange, TEFLON with spring LOADED (NOTE 6)	17	203-0405	B
Adapter, BUNA-N	22	203-0701	B
Adapter, VITON	22	203-0702	B
Adapter, TEFLON	22	203-0703	B
Adapter, ETHYLENE/PROPYLENE	22	203-0704	B
TERMINAL HOLDING SCREW			
Housing in Aluminum	12	304-0119	
Housing in 316 Stainless Steel	12	204-0119	
MAIN BOARD SCREW HOUSING IN ALUMINUM			
Units with indicator	3	304-0118	
Units without indicator	3	304-0117	
MAIN BOARD SCREW HOUSING IN 316 STAINLESS STEEL			
Units with indicator	3	204-0118	
Units without indicator	3	204-0117	
FLANGE BOLT			
Carbon Steel	16	203-0300	
Stainless Steel 316	16	203-0310	
FLANGE NUT			
Carbon Steel	20	203-0302	
Stainless Steel 316	20	203-0312	
ADAPTER BOLT			
Carbon Steel	23	203-0350	
Stainless Steel 316	23	203-0351	
DRAIN/VENT SCREW			
Stainless Steel 316	21	203-1401	A
Hastelloy C276	21	203-1402	A
Monel 400	21	203-1403	A
FLANGE PLUG (STOPPER)A			
Stainless Steel 316	14	203-0552	
Hastelloy C276	14	203-0553	
Monel 400	14	203-0554	
MOUNTING BRACKET FOR 2" PIPE MOUNTING (NOTE 5)			
Carbon Steel	-	203-0801	
Stainless Steel 316	-	203-0802	
Carbon Steel with bolts, nuts, washers and U-clamp in 316SS	-	203-0803	
LOCAL ADJUSTMENT PROTECTION CAP	9	204-0114	
SENSOR	25	(NOTE 4)	B

SPARE PARTS LIST			
DESCRIPTION OF PARTS	POSITION	CODE	CATEGORY (NOTE 1)
DRAIN/VENT VALVE			
316 SST	28	400-0792	
PLUG			
1/2 NPT Internal Hexagon Plug in Plated CS (Ex d)	27	400-0808	
1/2 NPT Internal Hexagon Plug in 304 SST (Ex d)	27	400-0809	
M20 X 1.5 External Hexagon Plug in 316 SST (Ex d)	27	400-0810	
PG 13.5 External Hexagon Plug in 316 SST (Ex d)	27	400-0811	
1/2 NPT Internal Socket Set Plug in Plated CS	27	400-0583-11	
1/2 NPT Internal Socket Set Plug in 304 SST	27	400-0583-12	
ADAPTER FOR ELECTRIC CONNECTION			
3/4 NPT female for 1/2 NPT male, SST 316	-	400-0812	

Table 4.2 - Spare Part List

NOTES

- 1 - For category A, it is recommended to keep, in stock, 25 parts installed for each set, and for category B, 50.
- 2 - Includes Terminal Block, Bolts, caps and Identification plate without certification.
- 3 - O'Rings and Backup Rings are packaged in packs of 12 units.
- 4 - To specify sensors, use the following tables.
- 5 - Including U-clamp, nuts, bolts and washers.
- 6 - For this type, O'Ring pack has 1 piece.

Smar Insulator Kit

The Insulator Kit Smar prevents the generation of galvanic current between metals when in contact. The difference of potential between the metals generates this current that flows from the metal with higher potential to the other. This process in the presence of aqueous solution with salts, acids or bases can start the corrosion process, where the corroded metal is always the one with bigger potential (anode).

In the processes, when it is impossible to isolate the two potencialized metals, occurs the generation of galvanic current. This current will form free ions of hydrogen (H+) in one of the solutions, with tendency to start the corrosion and the migration of the Hydrogen to the diaphragm of the Remote Seal or of the Level Transmitter.

The figure 6.3 shows the following parts that constitute the Smar Insulator Kit: Teflon Gasket (6), Nonmetallic Insulating Sleeve (4), Mica Washers (3) and Steel Washers (2).

Smar Insulator Kit Mounting

Mounting step by step:

- 1 – Insert all the Nonmetallic Insulating Sleeve (4); in the holes of the Sealed Flange (5);
- 2 – Put the Teflon Gasket (6) between the Flanges (5 e 7);
- 3 – Insert the Steel Washers (2) and the Mica Washers (3) in the bolts (1)
- 4 – Join the Flanges positioning its holes (5 and 7);
- 5 – Introduce the bolts in the holes of the flanges (5 and 7) and tighten the flanges with the nuts (8)
- 6 – Measure the resistance between the Sealed Flange (5) and the Flange of Process (7) that should be tending to the infinite to check the efficiency of the Insulator Kit.

NOTE

If the studs are used instead of the bolts, obey the same mounting sequence for the items 2, 3 and 4. This Insulator Kit can be applied with raised and flat face flanges.
The Gasket must be made of Teflon when the Smar Insulator Kit is indicated.

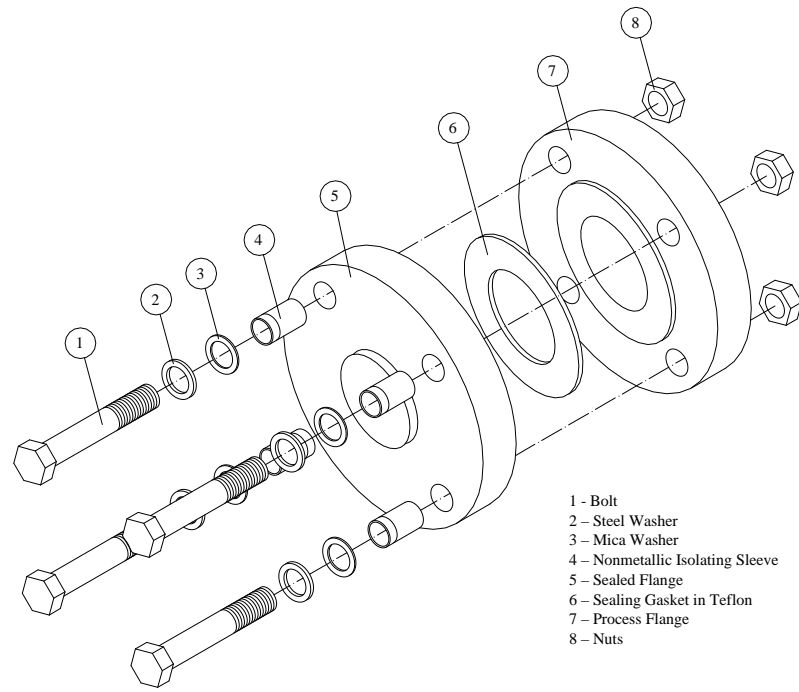

Figure 4.5 – Insulator Kit Mounting

INSULATOR KIT SPARE PARTS: LD300L					
ØN	GROUP	NORM	MODELS WITHOUT EXTENSION	MODELS WITH EXTENSION	
			LD300L / SR301T	LD300L / SR301E	
1"	150	ANSI B 16.5	400-0861-11X01	400-0861-11X11	
	300		400-0861-12X01	400-0861-12X11	
	600		400-0861-13X01	400-0861-13X11	
1.1/2"	150		400-0861-21X01	400-0861-21X11	
	300		400-0861-22X01	400-0861-22X11	
	600		400-0861-23X01	400-0861-23X11	
2"	150		400-0861-31X01	400-0861-31X11	
	300		400-0861-32X01	400-0861-32X11	
	600		400-0861-33X01	400-0861-33X11	
3"	150		400-0861-41X01	400-0861-41X11	
	300		400-0861-42X01	400-0861-42X11	
	600		400-0861-43X01	400-0861-43X11	
4"	150		400-0861-51X01	400-0861-51X11	
	300		400-0861-52X01	400-0861-52X11	
	600		400-0861-53X01	400-0861-53X11	
DN25	PN10/40		DIN EN1092-1	400-0861-64X01	400-0861-64X11
DN40	PN10/40			400-0861-74X01	400-0861-74X11
DN50	PN10/40			400-0861-84X01	400-0861-84X11
DN80	PN10/40	400-0861-94X01		400-0861-94X11	
DN100	PN16	400-0861-A8X01		400-0861-A8X11	
	PN40	400-0861-A4X01		400-0861-A4X11	
40A	20K	JIS B 2202	400-0861-B6X01	400-0861-B6X11	
50A	10K		400-0861-C5X01	400-0861-C5X11	
	40K		400-0861-C7X01	400-0861-C7X11	
80A	10K		400-0861-D5X01	400-0861-D5X11	
	20K		400-0861-D6X01	400-0861-D6X11	
100A	10K		400-0861-E5X01	400-0861-E5X11	

Table 4.3 – LD300L – Codes to the Spare parts of the Insulator Kit

See Figure 4.5.

SPARE PARTS: LD300L						
ØN	GROUP	NORM	GASKET			DRAIN VALVE
			TEFLON	COPPER	GRAFOIL	STAINLESS STEEL 316L
1"	ALL	ANSI-B16.5	400-0425	400-0426	400-0427	400-0792
1.1/2"	ALL		400-0428	400-0429	400-0430	
2"	ALL		400-0431	400-0432	400-0433	
3"	ALL		400-0434	400-0435	400-0436	
4"	ALL		400-0437	400-0438	400-0439	
DN25	ALL	EN 1092-1/2501	400-0440	400-0441	400-0442	
DN40	ALL		400-0443	400-0444	400-0445	
DN50	ALL		400-0446	400-0447	400-0448	
DN80	ALL		400-0449	400-0450	400-0451	
DN100	PN10/16		400-0452	400-0453	400-0454	
DN100	PN25/40		400-0455	400-0456	400-0457	

Table 4.4 – LD300L – Codes to the Spare parts of the Gasket

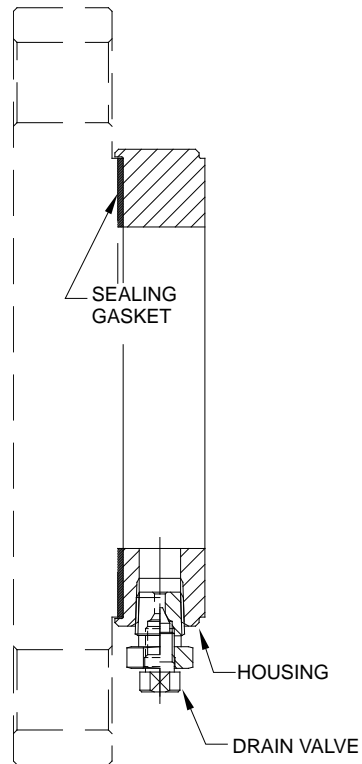

Figure 4.6 – LD300L- Sealing Gasket

RTJ SPARE PARTS: LD300L (without Extension)					
ØN	GROUP	NORM	RING	METALLIC RING	DRAIN VALVE
				STAINLESS STEEL 316L	STAINLESS STEEL 316L
1"	150	ANSI B 16.20 RTJ	R15	400-0887	400-0792
	300		R16	400-0888	
	600		R16	400-0888	
	1500		R16	400-0888	
	2500		R18	400-0889	
1.1/2"	150		R19	400-0890	
	300		R20	400-0891	
	600		R20	400-0891	
	1500		R20	400-0891	
	2500		R23	400-0893	
2"	150		R22	400-0892	
	300		R23	400-0893	
	600		R23	400-0893	
	1500		R24	400-0894	
	2500		R26	400-0895	
3"	150		R29	400-0896	
	300		R31	400-0897	
	600		R31	400-0897	
4"	150		R36	400-0900	
	300		R37	400-0901	
	600		R37	400-0901	

Table 4.5 – LD300L – Codes to the SST Metallic O-Ring

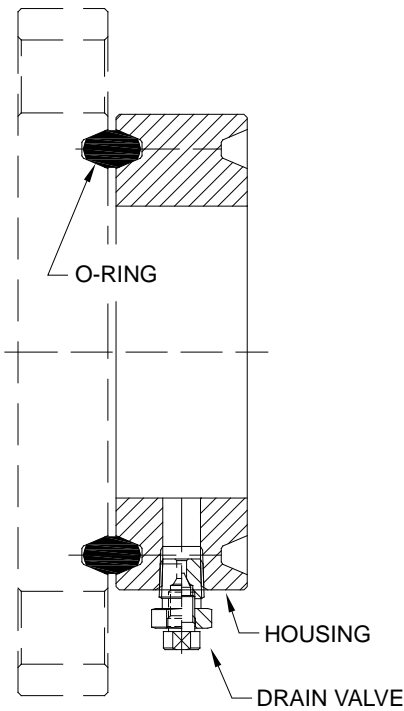

Figure 4.7 – SST Metallic O'Ring

ØN	CLASS	NORM	Ring	METALLIC RING
				316L SST
3"	1500	ANSI B 16.20 RTJ	R35	400-0899
	2500		R32	400-0898
4"	1500		R39	400-0903
	2500		R38	400-0902

Table 5.5 - LD300L – Special models for Gasket in Steel – Without Extension

Application with Halar

Technical Specification

Halar® is chemically one of the most resistant fluoropolymer. It is a thermoplastic of the melting process manufactured by Solvay Solexis, Inc. For its chemical structure, a 1:1 alternating ethylene copolymer and chlorinetrifluoroethylene, Halar® (*ECTFE*) offers an only combination of useful properties.

The diaphragms in 316L Stainless Steel covered with Halar®, are ideal for applications in contact with aggressive liquids. They offer excellent resistance to the chemic and abrasion with a wide temperature range. Halar® does not contaminate liquids of high purity and it is not affected by most of corrosive chemists, usually found in the industries, including strong minerals, oxidant acids, alkalis, liquid oxygen and some organic solvents.

Halar® is trademark of *Solvay Solexis, Inc.*

Performance Specification

For the performance specification see the equation below:

$$[1\% \text{ SPAN} \times (\text{URL}/\text{SPAN})] - \text{Included temperature error}^*$$

Diameters/Capillary Length:

- 2" ANSI B 16.5, DN 50 DIN, JIS 50 A, for seals up to 3 meters of capillary and level models (by inquiry).
- 3" ANSI B 16.5, DN 80 DIN, JIS 80 A, for seals up to 5 meters of capillary and level models.
- 4" ANSI B 16.5, DN 100 DIN, JIS 100 A, for seals up to 8 meters of capillary and level models.

*Temperature Limits:

- +10 to 100°C;
- +101 to 150°C (by inquiry).

TPE – Total Probable Error (Software)

Software to calculate the assembly error of the Pressure Transmitters with the possible connections to the process.

TPE was developed to a fast and effective aid of the products related the pressure measurement. The users are the Applications Engineer and Commercial Areas. The customer can request a report of performance estimate to Smar.

This product allows doing simulations of possible assemblies, verifying important data as the error estimates of the response time, of capillary length analysis and mechanical resistance of diaphragms with temperature variation. See an example in the Figure 5.8.

ETPNet 4.00 - Microsoft Internet Explorer

Address: <http://www.smar.net.com.br/etp/calcula/calculo.php>

Especificação dos equipamentos

LD300 (após out:2005)

Tipo:	D - Diferencial	ETP requerido:	5 %
Faixa:	Faixa 2 (50 kPa)	Estabilidade:	12 meses
Material do diafragma:	Inox 316	Estabilidade especial:	não
Óleo do sensor:	Silicone	Variação da alimentação:	1 V
Limite de medição:	0 até 50 kPa	Variação de pres.estática:	10 bar
Temperatura mínima:	10 °C	Vácuo:	não
Temperatura máxima:	40 °C		
Temperatura ajuste zero:	(Ajuste de Zero a 25 °C)		

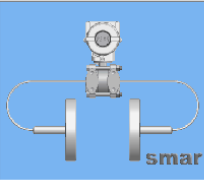

Conexões:

Material do diafragma:	Inox 316	Espessura do diafragma:	Padrão
Óleo de enchimento:	Silicone 200/20	Simetria térmica:	Simétrico
Projeto selo:	Modelo Jun/2008	Diâmetro interno capilar:	1.10 mm [Padrão]

Conexão high: SR301T (Tipo T)

Temp. processo mínima:	10 °C	Temp. processo máxima:	100 °C
Ø Conexão:	3 pol	Temp. capilar mínima:	10 °C
Capilar:	500 cm	Temp. capilar máxima:	40 °C

Conexão low: SR301T (Tipo T)

Temp. processo mínima:	10 °C	Temp. processo máxima:	100 °C
Ø Conexão:	3 pol	Temp. capilar mínima:	10 °C
Capilar:	500 cm	Temp. capilar máxima:	40 °C

Erro total provável

Exatidão:	0.08%	Temperatura mínima:	-0.06%
Estabilidade:	0.15% por 60.0 meses	Temperatura máxima:	0.06%
Pressão estática - zero:	0.00%	Desvio pela alimentação:	0.01%
Pressão estática - span:	0.03%	Tempo do transmissor:	0.1 s
ETP do transmissor para temp. mínimas:	0.10%	ETP do transmissor para temp. máximas:	0.10%
Temperatura lado high mínima:	-0.30%	Temperatura lado low mínima:	-0.30%
Temperatura lado high máxima:	0.49%	Temperatura lado low máxima:	0.49%

ETP

Erro Selo/nível para:	Temp. mínima	Temp. máxima
	0.17%	0.28%

Done Intranet local

Figure 4.8 – TPE Software Screen

Ordering Code for the Sensor

204 – 0301 SENSOR FOR DIFFERENTIAL , FLOW, GAGE, ABSOLUTE AND HIGH STATIC PRESSURE TRANSMITTER													
COD	Type	Range Limits		Min. Span	Unit	Range Limits		Min. Span	Unit				
		Min.	Max.			Min.	Max.						
D0	Differential and Flow	-1	1	0.05	kPa	-4	4	0.2	inH ₂ O	NOTE: The range can be extended up to 0.75 LRL* and 1.2 URL* with small degradation of accuracy. *LRL = Lower Range Limit. *URL = Upper Range Limit.			
D1	Differential and Flow	-5	5	0.13	kPa	-20	20	0.5	inH ₂ O				
D2	Differential and Flow	-50	50	0.42	kPa	-200	200	1.67	inH ₂ O				
D3	Differential and Flow	-250	250	2.08	kPa	-36	36	0.3	psi				
D4	Differential and Flow	-2500	2500	20.83	kPa	-360	360	3	psi				
M0	Gage	-1	1	0.05	kPa	-4	4	0.2	inH ₂ O				
M1	Gage	-5	5	0.13	kPa	-20	20	0.5	inH ₂ O				
M2	Gage	-50	50	0.42	kPa	-200	200	1.67	inH ₂ O				
M3	Gage	-100	250	2.08	kPa	-14.50	36	0.3	psi				
M4	Gage	-100	2500	20.83	kPa	-14.50	360	3	psi				
M5	Gage	-0.1	25	0.21	Mpa	-14.50	3600	30	psi				
M6	Gage	-0.1	40	0.33	Mpa	-14.50	5800	48.3	psi				
A1	Absolute	0	5	2.00	kPa	0	37	14.8	mmHga				
A2	Absolute	0	50	2.50	kPa	0	7.2	0.36	psia				
A3	Absolute	0	250	5.00	kPa	0	36	0.73	psia				
A4	Absolute	0	2500	20.83	kPa	0	360	3	psia				
A5	Absolute	0	25	0.21	Mpa	0	3600	30	psia				
A6	Absolute	0	40	0.33	Mpa	0	5800	48.3	psia				
H2	Differential – High Static Pressure	-50	50	0.42	kPa	-200	200	1.67	inH ₂ O				
H3	Differential – High Static Pressure	-250	250	2.08	kPa	-36	36	0.3	psi				
H4	Differential – High Static Pressure	-2500	2500	20.83	kPa	-360	360	3	psi				
H5	Differential – High Static Pressure	-25	25	0.21	Mpa	-3600	-3600	30	psi				
COD. Diaphragm Material and Fill Fluid													
1	316 SST	Silicone Oil (4)			8	Tantalum	Inert Oil Fluorolube (2)(3)(5)			K	Monel 400	Inert Oil Krytox (1) (3) (5)	
2	316 SST	Inert Oil Fluorolube (2) (5)			9	316L SST	Fomblim Oil			M	Monel 400 Gold Plated	Silicone Oil (1) (3) (4)	
3	Hastelloy C276	Silicone Oil (1) (4)			A	Monel 400	Fomblim Oil (1) (3)			P	Monel 400 Gold Plated	Inert Oil Krytox (1) (3) (5)	
4	Hastelloy C276	Inert Oil Fluorolube (1)(2)(5)			D	316L SST	Inert Oil Krytox (3) (5)			Q	316 SST	Inert Oil Halocarbon 4.2 (2) (3) (5)	
5	Monel 400	Silicone Oil (1) (3) (4)			E	Hastelloy C276	Inert Oil Krytox (1) (3) (5)			R	Hastelloy C276	Inert Oil Halocarbon 4.2 (2) (3) (5)	
7	Tantalum	Silicone Oil (3) (4)			G	Tantalum	Inert Oil Krytox (3) (5)			S	Tantalum	Inert Oil Halocarbon 4.2 (2) (3) (5)	

204 – 0301 D2 1 ← TYPICAL MODEL NUMBER

NOTES

- (1) Meets NACE MR – 01 – 75/ISO 15156 recommendations.
- (2) Not available for absolute models nor for vacuum applications.
- (3) Not available for range 0 and 1.
- (4) Silicone Oil is not recommended for oxygen (O₂) or Chlorine service.
- (5) Inert Fluid: Oxygen Compatibility, safe for oxygen service.

204-0301 SENSOR FOR FLANGED PRESSURE TRANSMITTER										
COD.	Range Limits		Min. Span	Unit	Range limits		Min. Span	Unit		
	Min.	Max.			Min.	Max.				
L2	-50	50	1.25	kPa	-200	200	5	inH ₂ O	Note: The range can be extended up to 0.75 LRL and 1.2 URL with small degradation of accuracy. The upper range value must be limited to the flange rating.	
L3	-250	250	2.08	kPa	-36	36	0.3	psi		
L4	-2500	2500	20.83	kPa	-360	360	3	psi		
L5	-25000	25000	208.3	kPa	-3625	3625	30.2	psi		
COD. Diaphragm material and Fill Fluid (Low Side)										
1	316L SST	Silicone Oil (2)		D	316L SST	Inert Oil Krytox (15)				
2	316L SST	Inert Oil Fluorolube (3) (15)		E	Hastelloy C276	Inert Oil Krytox (1) (15)				
3	Hastelloy C276	Silicone Oil (1) (2)		G	Tantalum	Inert Oil Krytox (15)				
4	Hastelloy C276	Inert Oil Fluorolube(1)(3)(15)		K	Monel 400	Inert Oil Krytox (1) (15)				
5	Monel 400	Silicone Oil (1) (2)		M	Monel 400 Gold Plated	Silicone Oil (1) (2)				
7	Tantalum	Silicone Oil (2)		P	Monel 400 Gold Plated	Inert Oil Krytox (1) (15)				
8	Tantalum	Inert Oil Fluorolube (3) (15)		Q	316L SST	Inert Oil Halocarbon 4.2 (15)				
9	316L SST	Fomblim Oil		R	Hastelloy C276	Inert Oil Halocarbon 4.2 (1) (15)				
A	Monel 400	Fomblim Oil (1)		S	Tantalum	Inert Oil Halocarbon 4.2 (15)				
COD. Flange, Adapter and Drain/Vent Valves material (Low Side)										
A	304L SST			M	Monel 400 (1)					
C	Plated CS (Drain/Vent in Stainless Steel) (16)			N	316 SST – CF8M (ASTM – A351) (Drain/Vent in Hastelloy C276) (1)					
H	Hastelloy C276 (CW – 12MW, ASTM – A494) (1)			P	316 SST – CF8M (ASTM – A351) Flange with PVDF (Kynar) insert (3) (4) (5)					
I	316 SST – CF8M (ASTM – A351)									
COD. Wetted O'Ring Material (Low Side)										
0	Without O'Rings			K	Kalrez					
B	Buna N			T	Teflon			Note: O'rings are not available on the sides with remote seals.		
E	Ethylene – Propylene			V	Viton					
COD. Drain/Vent Position (Low Side)										
0	Without Drain/Vent			D	Bottom			Note: For better Drain/Vent operation, vent valves are strongly recommended. Drain/Vent valve not available on the sides with remote seals.		
A	Drain/Vent (Opposite to Process Connection)			U	Top					
COD. Process Connection (Low Side)										
0	1/4 - 18 NPT (Without Adapter)			5	1/2 - 14 NPT Axial with PVDF Insert (3) (4) (6)			U Low Volume Flange For Level Welded		
1	1/2 - 14 NPT (Without Adapter)			9	Remote Seal (Low Volume Flange) (3) (7)			V Without Connection (Mounting With Gage Flange)		
3	Remote Seal (With Plug) (7)			T	1/2 14 BSP (With Adapter)			W Without Connection (Absolut Reference)		
COD. Process Connection (Level Tap)										
U	1" 150 # (ANSI B16.5) (18)			C	3" 600 # (ANSI B16.5)			S JIS 40A 20K (17)		
V	1" 300 # (ANSI B16.5) (18)			N	3" 600 # (ANSI B16.5 RTJ)			F JIS 50A 10K (17)		
W	1" 600 # (ANSI B16.5) (18)			3	4" 150 # (ANSI B16.5)			T JIS 50A 40K (17)		
O	1.1/2" 150 # (ANSI B16.5)			4	4" 300 # (ANSI B16.5)			K JIS 50A 20K (17)		
P	1.1/2" 300 # (ANSI B16.5)			D	4" 600 # (ANSI B16.5)			G JIS 80A 10K (17)		
Q	1.1/2" 600 # (ANSI B16.5)			5	DN 25 PN 10/40 (18)			L JIS 80A 20K (17)		
9	2" 150 # (ANSI B16.5)			R	DN 40 PN 10/40			H JIS 100A 10K (17)		
A	2" 300 # (ANSI B16.5)			E	DN 50 PN 10/40			M JIS 100A 10K (17)		
B	2" 600 # (ANSI B16.5)			6	DN 80 PN 10/40			Z User's specification		
1	3" 150 # (ANSI B16.5)			7	DN 100 PN 10/16					
2	3" 300 # (ANSI B16.5)			8	DN 100 PN 25/40					
COD. Type and Flange Material (Level Tap)										
2	316 SST (Integral Flange)			4	304 SST (Slip-on Flange)			6 Carbon Steel (Slip-on Flange)		
3	Hastelloy C276 (Integral Flange)			5	316 SST (Slip-on Flange)			Z User's specification		
COD. Extension Length										
0	0 mm (0")			3	150 mm (6")			Note: Extension Material 316 SST		
1	50 mm (2")			4	200 mm (8")					
2	100 mm (4")			Z	User's specification					
COD. Diaphragm Material / Extension (Level Tap)										
A	304L SST / 304L SST			6	316L SST with Teflon Lining (For 2" and 3")					
1	316L SST / 316 SST			7	316L SST Gold Plated					
2	Hastelloy C276 / 316 SST			B	Tantalum with Teflon Lining					
3	Monel 400 / 316 SST			L	316L SST Halar Plated (14)					
4	Tantalum / 316 SST (9)			C	Hastelloy Teflon Plated					
5	Titanium / 316 SST (9)									
COD. Fill Fluid										
1	DC – 200/20 Silicone Oil			G	Glycerin + water (11)					
3	DC704 Silicone Oil			B	Fomblim 06/06					
2	MO – 10 Fluorolube Oil (8)			H	Halocarbon 4.2					
4	Krytox Oil			T	Syltherm 800 Oil					
N	Neobee M20 Propylene Glycol Oil									
COD. Housing Material										
0	Without Housing (11)									
1	316 SST									
2	Hastelloy C276									
3	Super Duplex (UNS 32750) (10)									
4	Duplex (UNS 31803) (10)									
5	304L SST (10)									
COD. Gasket Material										
0	Without Gasket									
T	Teflon (PTFE)									
G	Grafoil (Flexible lead)									
C	Copper									
I	316 L SST									

204-0301 L2 1 I B U 0 1 2 2 1 1 1 1 T ← TYPICAL MODEL NUMBER

204-0301		SENSOR FOR FLANGED PRESSURE TRANSMITTER (CONTINUATION)	
CODE		Flanges Bolts and Nuts Material	
A0	Plated Carbon Steel (Default) (16)	A5	Hastelloy C276
A1	316 SST		
A2	Carbon Steel (ASTM A193 B7M) (1) (16)		
CODE		Flange thread for Fixing Accessories (Adapters, Manifolds, Mounting Brackets, etc)	
D0	7/16" UNF (Default)	D2	M12 X 1.75
D1	M10 X 1.5		
CODE		Flange Facing Finish	
Q0	Raised Face – RF (Default)		
Q1	Flat Face – FF		
Q2	Ring Joint Face – RTJ (Only available for ANSI standard flange) (12)		
Q3	Tongue Face (11)		
Q4	Grooved Face (11)		

204-0301 A0 D0 Q0 ← TYPICAL MODEL NUMBER

NOTES

- (1)** Meets NACE MR – 01 – 75/ISO 15156 recommendations.
- (2)** Silicone Oils not recommendations for Oxygen (O₂) or Chlorine service.
- (3)** Not applicable for vacuum service.
- (4)** Drain/Vent not applicable.
- (5)** O'Ring should be Viton or Kalrez.
- (6)** Maximum pressure 24 bar.
- (7)** For remote Seal only 316 SST - CF8M (ASTM A3510 flange is available (thread M12).
- (8)** Fluorolube fill fluid is not available for Monel diaphragm.
- (9)** Attention, check corrosion rate for the process, tantalum plate 0.1 mm, AISI 316L extension 3 to 6mm.
- (10)** Item by inquiry.
- (11)** Supplied without Gasket.
- (12)** Gasket for housing, available only in Stainless 316.
- (13)** Range of application of temperature from -40 °C to 150 °C.

- (14)** Applicable only to:
 - Thickness of steel: 0.05 mm
 - Diameter/capillary length:
 - 2" ANSI B 16.5 DN 50 DIN, JIS 50 A, for seals up to 3 meters of capillary and level models (by inquiry).
 - 3" ANSI B 16.5 DN 80 DIN, JIS 80 A, for seals up to 5 meters of capillary and level models.
 - Faces: RF and FF;
 - Temperature Range: +10 to 100 °C
+ 101 to 150 °C (by inquiry)
 - Not applicable for diaphragm thickness;
 - Not applicable for use with gaskets.
- (15)** Inert Fluid: safe for oxygen service.
- (16)** Not applicable for saline atmosphere.
- (17)** Not available for slip-on flange.
- (18)** Not available for integral flange.

204-0301 SENSOR FOR SANITARY PRESSURE TRANSMITTER

COD.	Range Limits		Min. Span	Unit	Range limits		Min. Span	Unit	
	Min.	Max.			Min.	Max.			
S2	-50	50	1.25	kPa	-200	200	5	inH ₂ O	Note: The range can be extended up to 0.75 LRL and 1.2 URL with small degradation of accuracy. The upper range value must be limited to the flange rating.
S3	-250	250	2.08	kPa	-36	36	0.3	psi	
S4	-2500	2500	20.83	kPa	-360	360	3	psi	
S5	-25000	25000	208.3	kPa	-3625	3625	30.2	psi	

COD. Diaphragm material and Fill Fluid (Low Side)									
1	316L SST	Silicone Oil (2)	D	316L SST	Inert Oil Krytox (12)				
2	316L SST	Inert Oil Fluorolube (3) (12)	E	Hastelloy C276	Inert Oil Krytox (1) (12)				
3	Hastelloy C276	Silicone Oil (1) (2)	G	Tantalum	Inert Oil Krytox (12)				
4	Hastelloy C276	Inert Oil Fluorolube(1)(3)(12)	K	Monel 400	Inert Oil Krytox (1) (12)				
5	Monel 400	Silicone Oil (1) (2)	M	Monel 400 Gold Plated	Silicone Oil (1) (2)				
7	Tantalum	Silicone Oil (2)	P	Monel 400 Gold Plated	Inert Oil Krytox (1) (12)				
8	Tantalum	Inert Oil Fluorolube (3) (12)	Q	316L SST	Inert Oil Halocarbon 4.2 (12)				
9	316L SST	Fomblim Oil	R	Hastelloy C276	Inert Oil Halocarbon 4.2 (1) (12)				
A	Monel 400	Fomblim Oil (1)	S	Tantalum	Inert Oil Halocarbon 4.2 (12)				

COD. Flange, Adapter and Drain/Vent Valves material (Low Side)									
C	Plated CS (Drain/Vent in Stainless Steel) (13)				M	Monel 400 (1)			
H	Hastelloy C276 (CW – 12MW, ASTM – A494) (1)				N	316 SST – CF8M (ASTM – A351) (Drain/Vent in Hastelloy C276) (1)			
I	316 SST – CF8M (ASTM – A351)				P	316 SST – CF8M (ASTM – A351) Flange with PVDF (Kynar) insert (3) (4) (5)			

COD. Wetted O'Ring Material (Low Side)									
0	Without O'Rings			K	Kalrez				
B	Buna N			T	Teflon				
E	Ethylene – Propylene			V	Viton				

Note: O'rings are not available on the sides with remote seals.

COD. Drain/Vent Position (Low Side)									
0	Without Drain/Vent				D	Bottom			
A	Drain/Vent (Opposite to Process Connection)				U	Top			

Note: For better Drain/Vent operation, vent valves are strongly recommended. Drain/Vent valve not available on the sides with remote seals.

COD. Process Connection (Low Side)									
0	1/4 - 18 NPT (Without Adapter)				5	1/2 - 14 NPT Axial with PVDF Insert (3) (4) (6)			
1	1/2 - 14 NPT (Without Adapter)				9	Remote Seal (Low Volume Flange) (3) (7)			
3	Remote Seal (With Plug) (7)				U	Low Volume Flange For Level Welded			
					V	Without Connection (Mounting With Gage Flange)			
					W	Without Connection (Absolut Reference)			

COD. Process Connection (Level tap)									
8	Threaded DN25 DIN 11851 – with extension (9)				E	Threaded SMS 2" – without extension (9)			
9	Threaded DN40 DIN 11851 - with extension (9)				M	Threaded SMS 3" - with extension (9)			
H	Threaded DN40 DIN 11851 – without extension (9)				1	Threaded SMS 3" - without extension (9)			
V	Threaded DN50 DIN 11851 - with extension (9)				F	Tri-Clamp 1 1/2" – without extension			
U	Threaded DN50 DIN 11851 - without extension (9)				Q	Tri-Clamp 1 1/2" HP (High Pressure) - without extension (8)			
X	Threaded DN80 DIN 11851 - with extension (9)				6	Tri-Clamp 2" - with extension			
W	Threaded DN80 DIN 11851 - without extension (9)				D	Tri-Clamp 2" – without extension			
4	Threaded IDF 2" - with extension (9)				N	Tri-Clamp 2" HP (High Pressure) - with extension (8)			
B	Threaded IDF 2" – without extension (9)				P	Tri-Clamp 2" HP (High Pressure) – without extension (8)			
K	Threaded IDF 3" - with extension (9)				I	Tri-Clamp 3" - with extension			
3	Threaded IDF 3" - without extension (9)				G	Tri-Clamp 3" – without extension			
5	Threaded RJT 2" - with extension (9)				J	Tri-Clamp 3" HP (High Pressure) - with extension (8)			
C	Threaded RJT 2" - without extension (9)				R	Tri-Clamp 3" HP (High Pressure) – without extension o (8)			
L	Threaded RJT 3" - with extension (9)				A	Tri-Clamp DN50 - with extension			
2	Threaded RTJ 3" - without extension (9)				O	Tri-Clamp DN50 HP (High Pressure) - with extension (8)			
S	Threaded SMS 1 1/2" – without extension (9)				T	Tri-Clamp DN50 – without extension			
7	Threaded SMS 2" - with extension (9)				Z	User's specification			

COD. Flange Material (Level Tap)									
2	316 SST				Z	User's specification			

COD. Diaphragm Material (Level Tap)									
1	316L SST				6	316L SST with Teflon Lining (For 2"and 3")			
2	Hastelloy C276				7	316L SST Gold Plated			
3	Monel 400				B	Tantalum with Teflon Lining			
4	Tantalum (10)				L	316L SST Halar Plated (20)			
5	Titanium (10)				C	Hastelloy Teflon Plated			

COD. Fill Fluid									
1	DC – 200/20 Silicone Oil				G	Glycerin + water (11)			
3	DC704 Silicone Oil				B	Fomblim 06/06			
2	MO – 10 Fluorolube Oil (8)				H	Halocarbon 4.2			
4	Krytox Oil				T	Syltherm 800 Oil			
N	Neobee M20 Propylene Glycol Oil (Approved 3A) (10) (14)								

204-0301 L2 1 I B U 0 1 2 2 1 ← TYPICAL MODEL NUMBER

204-0301	SENSOR FOR SANITARY PRESSURE TRANSMITTER (CONTINUATION)		
	CODE	Flanges Bolts and Nuts Material	
	A0	Plated Carbon Steel (Default) (13)	
	A1	316 SST	A5 Hastelloy C276
	A2	Carbon Steel (ASTM A193 B7M) (1) (13)	
	CODE	Flange Thread for Fixing Accessories (Adapters, Manifolds, Mounting Brackets, etc)	
	D0	7/16" UNF (Default)	D2 M12 X 1.75
	D1	M10 X 1.5	

204-0301 A0 D0 ← TYPICAL MODEL NUMBER

NOTES

- (1) Meets NACE MR – 01 – 75/ISO 15156 recommendations.
- (2) Silicone Oils not recommendations for Oxygen (O₂) or Chlorine service.
- (3) Not applicable for vacuum service.
- (4) Drain/Vent not applicable.
- (5) O'Ring should be Viton or Kalrez.
- (6) Maximum pressure 24 bar.
- (7) For remote Seal only 316 SST - CF8M (ASTM A3510 flange is available (thread M12).
- (8) HP – High Pressure
- (9) Not available for tri-clamp connections.
- (10) 3A-7403 Standard:
 - Neobee M2O Fill Fluid
 - Finishing wet Face: 0,8 µm Ra (32 µ" AA)
 - Wet O-Ring: Viton
- (11) Item by inquire.
- (12) Inert Fluid: Oxygen Compatibility, safe for oxygen service.
- (13) Not applicable for saline atmosphere.
- (14) Compliant with 3A-7403 standard for food and other applications where sanitary connections are required.

TECHNICAL CHARACTERISTIC

Functional Specifications																																																																									
Process Fluid	Liquid, gas or vapor.																																																																								
Output	Digital only. Complies with IEC 61158-2 (H1): 31.25kbit/s voltage mode, bus powered.																																																																								
Power Supply	Bus powered: 9 – 32 Vdc. Quiescent current consumption: 12 mA																																																																								
Indicator	4 1/2 -digit numerical and 5-character alphanumeric LCD indicator (optional).																																																																								
Hazardous Area Certifications	Explosion proof (FM, CSA, NEMKO, CEPEL), intrinsic safe (FM, CSA, NEMKO, EXAM, CEPEL, NEPSI), dust ignition proof and non-incendive (FM). FISCO Field Device Ex ia IIC T4 (FM, CSA, NEMKO, EXAM, CEPEL, NEPSI) FNICO Field Device Ex n1 IIC T4 (FM, CSA, NEMKO, EXAM, CEPEL)																																																																								
European Directive Information	<p>Authorized representative in European Community Smar GmbH-Rheingaustrasse 9-55545 Bad Kreuznach</p> <p>PED Directive (97/23/EC) – Pressure Equipment Directive This product is in compliance with the directive and it was designed and manufactured in accordance with sound engineering practice using several standards from ANSI, ASTM, DIN and JIS.</p> <p>EMC Directive (2004/108/EC) - Eletromagnetic Compatibility The EMC test was performed according to IEC standard: IEC61326-1:2006, IEC61326-2-3:2006, IEC61000-6-4:2006, IEC61000-6-2:2005. For use in environment only. Keep the shield insulated at the instrument side, connecting the other one to the ground if necessary to use shielded cable.</p> <p>ATEX Directive (94/9/EC) – Equipment and protective systems intended for use in potentially explosive atmospheres This product was certified according European Standards at NEMKO and EXAM (old DMT). The certified body for manufacturing quality assessment is EXAM (number 0158).</p> <p>LVD Directive 2006/95/EC – Electrical Equipment designed for use within certain voltage limits According the LVD directive Annex II the equipment under ATEX “Electrical equipment for use in an explosive atmosphere” directive are excluded from scope from this directive.</p> <p>The EC declarations of conformity for all applicable European directives for this product can be found at www.smar.com.</p>																																																																								
Zero and Span Adjustments	No interactive, via digital communication.																																																																								
Failure Alarm (Diagnostics)	For sensor or circuit failures, status is sent to output parameters. Detailed diagnostics are available in the contained parameters.																																																																								
Temperature Limits	<table border="0"> <tr> <td>Ambient:</td> <td>-40</td> <td>to</td> <td>85 °C</td> <td>(-40</td> <td>to</td> <td>185 °F)</td> <td></td> </tr> <tr> <td>Process:</td> <td>-40</td> <td>to</td> <td>100 °C</td> <td>(-40</td> <td>to</td> <td>212 °F)</td> <td>(Silicone oil)</td> </tr> <tr> <td></td> <td>0</td> <td>to</td> <td>85 °C</td> <td>(32</td> <td>to</td> <td>185 °F)</td> <td>(Halocarbon and Fluorolube oil)</td> </tr> <tr> <td></td> <td>-20</td> <td>to</td> <td>85 °C</td> <td>(-4</td> <td>to</td> <td>185 °F)</td> <td>(Krytox oil and Fomblim oil)</td> </tr> <tr> <td></td> <td>-25</td> <td>to</td> <td>85 °C</td> <td>(-13</td> <td>to</td> <td>185 °F)</td> <td>(Viton O-ring)</td> </tr> <tr> <td>Storage:</td> <td>-40</td> <td>to</td> <td>150 °C</td> <td>(-40</td> <td>to</td> <td>302 °F)</td> <td>(LD303L)</td> </tr> <tr> <td>Display:</td> <td>-40</td> <td>to</td> <td>100 °C</td> <td>(-40</td> <td>to</td> <td>212 °F)</td> <td></td> </tr> <tr> <td></td> <td>-20</td> <td>to</td> <td>80 °C</td> <td>(-4</td> <td>to</td> <td>176 °F)</td> <td></td> </tr> <tr> <td></td> <td>-40</td> <td>to</td> <td>85 °C</td> <td>(-40</td> <td>to</td> <td>185 °F)</td> <td>(Without damage)</td> </tr> </table>	Ambient:	-40	to	85 °C	(-40	to	185 °F)		Process:	-40	to	100 °C	(-40	to	212 °F)	(Silicone oil)		0	to	85 °C	(32	to	185 °F)	(Halocarbon and Fluorolube oil)		-20	to	85 °C	(-4	to	185 °F)	(Krytox oil and Fomblim oil)		-25	to	85 °C	(-13	to	185 °F)	(Viton O-ring)	Storage:	-40	to	150 °C	(-40	to	302 °F)	(LD303L)	Display:	-40	to	100 °C	(-40	to	212 °F)			-20	to	80 °C	(-4	to	176 °F)			-40	to	85 °C	(-40	to	185 °F)	(Without damage)
Ambient:	-40	to	85 °C	(-40	to	185 °F)																																																																			
Process:	-40	to	100 °C	(-40	to	212 °F)	(Silicone oil)																																																																		
	0	to	85 °C	(32	to	185 °F)	(Halocarbon and Fluorolube oil)																																																																		
	-20	to	85 °C	(-4	to	185 °F)	(Krytox oil and Fomblim oil)																																																																		
	-25	to	85 °C	(-13	to	185 °F)	(Viton O-ring)																																																																		
Storage:	-40	to	150 °C	(-40	to	302 °F)	(LD303L)																																																																		
Display:	-40	to	100 °C	(-40	to	212 °F)																																																																			
	-20	to	80 °C	(-4	to	176 °F)																																																																			
	-40	to	85 °C	(-40	to	185 °F)	(Without damage)																																																																		
Turn-on Time	Performs within specifications in less than 10 seconds after power is applied to the transmitter.																																																																								
Configuration	Basic configuration may be done using the local adjustment magnetic tool if device is fitted with display. Complete configuration is possible using configuration tools.																																																																								
Volumetric Displacement	Less than 0.15 cm ³ (0.01 in ³)																																																																								
Overpressure and Static Pressure Limits (MWP – Maximum Working Pressure)	<p>From 3.45 kPa abs. (0.5 psia)* to: 70 psi (5 bar) for range 0 1200 psi (80 bar) for range 1 2300 psi (160 bar) for ranges 2, 3 and 4 4600 psi (320 bar) for models H2 and H5 5800 psi (400 bar) for range 5 7500 psi (520 bar) for range 6 * except the LD301A model</p> <p>Flange Test Pressure: 68.95 MPa (10,000 psi) Overpressures above will not damage the transmitter, but a new calibration may be necessary.</p> <div style="border: 1px solid black; padding: 5px; margin-top: 10px;"> <p style="text-align: center;">WARNING</p> <p>It is described here only the maximum pressures of the materials referenced in each rule, it can not be manufactured on request.</p> <p>Temperatures above 150 ° C are not available in standard models.</p> </div>																																																																								

Functional Specifications

PRESSURES TABLE FOR SEAL AND LEVEL FLANGES DIN EN 1092-1 2008 STANDARD

Material Group	Pressure Class	Maximum Temperature Allowed						
		RT	100	150	200	250	300	350
		Maximum Pressure Allowed (bar)						
10E0 AISI 304/304L	PN 16	16	13.7	12.3	11.2	10.4	9.6	9.2
	PN 25	25	21.5	19.2	17.5	16.3	15.1	14.4
	PN 40	40	34.4	30.8	28	26	24.1	23
	PN 63	63	63	57.3	53.1	50.1	46.8	45
	PN 100	100	86.1	77.1	70	65.2	60.4	57.6
	PN 160	160	137.9	123.4	112	104.3	96.7	92.1
	PN 250	250	215.4	192.8	175	163	151.1	144

Material Group	Pressure Class	Maximum Temperature Allowed						
		RT	100	150	200	250	300	350
		Maximum Pressure Allowed (bar)						
14E0 AISI 316/316L	PN 16	16	16	14.5	13.4	12.7	11.8	11.4
	PN 25	25	25	22.7	21	19.8	18.5	17.8
	PN 40	40	40	36.3	33.7	31.8	29.7	28.5
	PN 63	63	63	57.3	53.1	50.1	46.8	45
	PN 100	100	100	90.9	84.2	79.5	74.2	71.4
	PN 160	160	160	145.5	134.8	127.2	118.8	114.2
	PN 250	250	250	227.3	210.7	198.8	185.7	178.5

Material Group	Pressure Class	Maximum Temperature Allowed						
		RT	100	150	200	250	300	350
		Maximum Pressure Allowed (bar)						
16E0 1.4410 Super Duplex 1.4462 Duplex	PN 16	16	16	16	16	16	-	-
	PN 25	25	25	25	25	25	-	-
	PN 40	40	40	40	40	40	-	-
	PN 63	63	63	63	63	63	-	-
	PN 100	100	100	100	100	100	-	-
	PN 160	160	160	160	160	160	-	-
	PN 250	250	250	250	250	250	-	-

PRESSURES TABLE FOR SEAL AND LEVEL FLANGES ASME B16.5 2009 STANDARD

Material Group	Pressure Class	Maximum Temperature Allowed								
		-29 to 38	50	100	150	200	250	300	325	350
		Maximum Pressure Allowed (bar)								
Hastelloy C276	150	20	19.5	17.7	15.8	13.8	12.1	10.2	9.3	8.4
	300	51.7	51.7	51.5	50.3	48.3	46.3	42.9	41.4	40.3
	400	68.9	68.9	68.7	66.8	64.5	61.7	57	55	53.6
	600	103.4	103.4	103	100.3	96.7	92.7	85.7	82.6	80.4
	900	155.1	155.1	154.6	150.6	145	139	128.6	124	120.7
	1500	258.6	258.6	257.6	250.8	241.7	231.8	214.4	206.6	201.1
	2500	430.9	430.9	429.4	418.2	402.8	386.2	357.1	344.3	335.3

Material Group	Pressure Class	Maximum Temperature Allowed								
		-29 to 38	50	100	150	200	250	300	325	350
		Maximum Pressure Allowed (bar)								
S31803 Duplex S32750 Super Duplex	150	20	19.5	17.7	15.8	13.8	12.1	10.2	9.3	8.4
	300	51.7	51.7	50.7	45.9	42.7	40.5	38.9	38.2	37.6
	400	68.9	68.9	67.5	61.2	56.9	53.9	51.8	50.9	50.2
	600	103.4	103.4	101.3	91.9	85.3	80.9	77.7	76.3	75.3
	900	155.1	155.1	152	137.8	128	121.4	116.6	114.5	112.9
	1500	258.6	258.6	253.3	229.6	213.3	202.3	194.3	190.8	188.2
	2500	430.9	430.9	422.2	382.7	355.4	337.2	323.8	318	313.7

Functional Specifications												
	Material Group	Pressure Class	Maximum Temperature Allowed									
			-29 to 38	50	100	150	200	250	300	325	350	
	AISI316L	Pressure Class	Maximum Pressure Allowed (bar)									
			150	15.9	15.3	13.3	12	11.2	10.5	10	9.3	8.4
			300	41.4	40	34.8	31.4	29.2	27.5	26.1	25.5	25.1
			400	55.2	53.4	46.4	41.9	38.9	36.6	34.8	34	33.4
			600	82.7	80	69.6	62.8	58.3	54.9	52.1	51	50.1
			900	124.1	120.1	104.4	94.2	87.5	82.4	78.2	76.4	75.2
			1500	206.8	200.1	173.9	157	145.8	137.3	130.3	127.4	125.4
	2500	344.7	333.5	289.9	261.6	243	228.9	217.2	212.3	208.9		
	AISI316	Pressure Class	Maximum Temperature Allowed									
			-29 to 38	50	100	150	200	250	300	325	350	
			150	19	18.4	16.2	14.8	13.7	12.1	10.2	9.3	8.4
300			49.6	48.1	42.2	38.5	35.7	33.4	31.6	30.9	30.3	
400			66.2	64.2	56.3	51.3	47.6	44.5	42.2	41.2	40.4	
600			99.3	96.2	84.4	77	71.3	66.8	63.2	61.8	60.7	
900			148.9	144.3	126.6	115.5	107	100.1	94.9	92.7	91	
1500	248.2	240.6	211	192.5	178.3	166.9	158.1	154.4	151.6			
2500	413.7	400.9	351.6	320.8	297.2	278.1	263.5	257.4	252.7			
Humidity Limits	0 to 100% RH											
Damping Adjustment	User configurable from 0 to 128 seconds (via digital communication).											

Performance Specifications	
Reference Conditions	Span starting at zero, temperature of 25°C (77°F), atmospheric pressure, power supply of 24 Vdc, silicone oil fill fluid, isolating diaphragms in 316L SST and digital trim equal to lower and upper range values.
Accuracy	<p>For differential and gage transmitters ranges 1, 2, 3, 4, 5 and 6: 0.1 URL ≤ span ≤ URL: ± 0.075% of span 0.025 URL ≤ span < 0.1 URL: ± [0.0375 + 0.00375 URL/span]% of span 0.0085 URL ≤ span < 0.025 URL: ± [0.0015+0.00465 URL/span]% of span</p> <p>For Absolute transmitters ranges 2, 3, 4, 5 and 6, diaphragms in Tantalum or Monel or fill fluid in Fluorolube: 0.1 URL ≤ span ≤ URL: ± 0.1% of span 0.025 URL ≤ span < 0.1 URL: ± [0.05 + 0.005 URL/span]% of span 0.0085 URL ≤ span < 0.025 URL: ± [0.01 + 0.006 URL/span]% of span</p> <p>For range 0, differential and gage models, diaphragms in SST 316L and fill fluid in Silicone or Halocarbon: 0.2 URL ≤ span ≤ URL: ± 0.1% of span 0.05 URL ≤ span < 0.2 URL: ± [0.025 + 0.015 URL/span]% of span</p> <p>For Absolute, range 1: 0.2% of span Linearity, hysteresis and repeatability effects are included.</p>
Stability	<p>For ranges 2, 3, 4, 5 and 6: ± 0.15% of URL for 5 years at 20 °C temperature change and up 7 MPa (1000 psi) of static pressure For ranges 0 and 1: ± 0.2% of URL for 12 months at 20 °C temperature change and up to 100 kPa (1 bar) of static pressure For level transmitters: ± 0.2% of URL for 12 months at 20 °C temperature change</p>
Temperature Effect	<p>For ranges 2, 3, 4, 5 and 6: 0.2 URL ≤ span ≤ URL: ± [0.02% URL + 0.06% span] per 20 °C (36 °F) 0.0085 URL ≤ span < 0.2 URL: ± [0.023% URL + 0.045% span] per 20 °C (36 °F)</p> <p>For range 1: 0.2 URL ≤ span ≤ URL: ± [0.08% URL + 0.05% span] per 20 °C (36 °F) 0.025 URL ≤ span < 0.2 URL: ± [0.06% URL + 0.15% span] per 20 °C (36 °F)</p> <p>For range 0: 0.2 URL ≤ span ≤ URL: ± [0.15% URL + 0.05% span] per 20 °C (36 °F) 0.05 URL ≤ span < 0.2 URL: ± [0.1% URL + 0.3% span] per 20 °C (36 °F)</p> <p>For LD303L: 6 mmH₂O per 20 °C for 4" and DN100 17 mmH₂O per 20 °C for 3" and DN80 Consult for other flange dimensions and fill fluid.</p>

Performance Specifications	
Static Pressure Effect	<p>Zero error: For ranges 2, 3, 4, 5 and 6: $\pm 0.033\%$ of URL per 7MPa (1000 psi) For range 1: $\pm 0.05\%$ of URL per 1.7 MPa (250 psi) For range 0: $\pm 0.1\%$ of URL per 0.5 MPa (5 bar) For level transmitters: $\pm 0.1\%$ of URL per 3.5 MPa (500 psi) The zero error is a systematic error that can be eliminated by calibrating at the operating static pressure.</p> <p>Span error: For ranges 2, 3, 4, 5 and 6: correctable to $\pm 0.2\%$ of reading per 7MPa (1000 psi) For range 1 and level transmitters: correctable to $\pm 0.2\%$ of reading per 3.5 MPa (500 psi) For range 0: correctable to $\pm 0.2\%$ of reading per 0.5 MPa (5 bar)</p>
Power Supply Effect	$\pm 0.005\%$ of calibrated span per volt
Mounting Position Effect	Zero shift of up to 250 Pa (1 inH ₂ O) which can be calibrated out. No span effect.
Electromagnetic Interference Effect	Approved according to IEC61326-1:2006, IEC61326-2-3:2006, IEC61000-6-4:2006, IEC61000-6-2:2005.

NOTE
<p>URL = Upper range limit. LRL = Lower range limit.</p>

Physical Specifications	
Electrical Connection	<p>1/2 - 14 NPT M20 X 1.5 PG 13.5 DIN 3/4 - 14 NPT (with 316 SST adapter for 1/2 - 14 NPT) 3/4 - 14 BSP (with 316 SST adapter for 1/2 - 14 NPT) 1/2 - 14 BSP (with 316 SST adapter for 1/2 - 14 NPT)</p> <p>Note: Explosion Proof approvals do not apply to adapter, only to Transmitter.</p>
Process Connection	<p>1/4 - 18 NPT or 1/2 -14 NPT (with adapter) For L models see Ordering Code. See Ordering Code for more options.</p>
Wetted Parts	<p>Isolating Diaphragms: 316L SST, Hastelloy C276, Monel 400 or Tantalum</p> <p>Drain/Vent Valves and Plug: 316 SST, Hastelloy C276 or Monel 400</p> <p>Flanges: Plated Carbon Steel, 316 Stainless Steel - CF8M (ASTM - A351), Hastelloy C276 (CW-12MW, ASTM - A494) or Monel 400</p> <p>Wetted O-Rings (For Flanges and Adapters): Buna N, Viton™, PTFE or Ethylene-Propylene. The LD303 is available in NACE MR-01-75/ISO 15156 compliant materials.</p>
Nonwetted Parts	<p>Electronic Housing: Injected aluminum with polyester painting, epoxy painting or 316 SST - CF8M (ASTM - A351) housing. Complies with NEMA 4X/6P, IP66 or IP66W*, IP68 or IP68W*. *The IP66/68W sealing test (immersion) was performed at 1 bar for 24 hours. For any other situation, please consult Smar. IP66/68W tested for 200h to according NBR 8094 / ASTM B 117 standard.</p> <p>Blank Flange: When flange adapter and Drain/Vent material is carbon steel, blank flange is in carbon steel, otherwise blank flange is in 316 SST - CF8M (ASTM - A351)</p> <p>Level Flange (LD303L): 316 L SST, 304 SST, Hastelloy C276 and Plated Carbon Steel.</p> <p>Fill Fluid: Silicone, Fluorolube, Krytox, Halocarbon 4.2 or Fomblim oils</p> <p>Cover O-Rings: Buna N</p> <p>Mounting Bracket: Plated carbon steel or 316 SST Accessories (bolts, nuts, washers and U-clamps) in carbon steel or 316 SST</p> <p>Flange Bolts and Nuts: Plated carbon steel, Grade 8 or 316 SST For NACE applications: carbon steel ASTM A193 B7M</p> <p>Identification Plate: 316 SST</p>

Physical Specifications	
Mounting	a) Flange mounted for Level models. b) Optional universal mounting bracket for surface or vertical/horizontal 2"-pipe (DN 50). c) Manifold Valve integrated to the transmitter. d) Directly on piping for closely coupled transmitter/orifice flange combinations.
Approximate Weights	3.15 kg (7 lb): all models, except L models. 5.85 to 9.0 kg (13 lb to 20 lb): L models depending on the flanges, extension and materials.
Control Functions Characteristics (Optional)	Function Blocks: Transducer (TRD), Display Transducer (DSP), Analog Input (AI) and Totalization (TOT).

Technical Characteristics of High Performance - CODE L1

High Performance option (code L1) is available under the following conditions only:

Application	Differential and Gage
Range	D2 -50 to 50 kPa -200 to 200 inH ₂ O D3 -250 to 250 kPa -36 to 36 psi D4 -2500 to 2500 kPa -360 to 360 psi M2 -50 to 50 kPa -200 to 200 inH ₂ O M3 -100 to 250 kPa -14.5 to 36 psi M4 -100 to 2500 kPa -14.5 to 360 psi
Diaphragm Material	316L SST Hastelloy C276
Fill fluid	Silicone

Performance Specifications	
Reference Conditions	Span starting at zero, temperature of 25 °C (77 °F), atmospheric pressure, power supply of 24 Vdc, silicone oil fill fluid, isolating diaphragms in 316L SST and digital trim equal to lower and upper range values.
Accuracy	RANGE 2: 0.2 URL ≤ span ≤ URL: ± 0.04% of span 0.05 URL ≤ span < 0.2 URL: ± [0.021667 + 0.003667 URL/span]% of span 0.0085 URL ≤ span < 0.05 URL: ± [0.0021 + 0.004645 URL /span]% of span RANGES 3 and 4: 0.1 URL ≤ span ≤ URL: ± 0.05% of span; 0.05 URL ≤ span < 0.1 URL: ± [0.005 + 0.045 URL/span]% of span 0.0085 URL ≤ span < 0.05 URL: ± [0.0021+ 0.004645 URL/span]% of span
Stability	For range 2: ± 0.05% of URL for 6 months For range 3: ± 0.075% of URL for 12 months For range 4: ± 0.1% of URL for 24 months ± 0.2% of URL for 12 years, at 20 °C temperature change and up to 7 MPa (1000 psi) (70 bar) of static pressure, environment free of hydrogen migration.
Temperature Effect	From -10 °C to 50 °C, protected from direct sun radiation: 0.2 URL ≤ span ≤ URL: ± [0.018% URL + 0.012% span] per 20 °C (68 °F) 0.0085 URL ≤ span < 0.2% URL: ± [0.002% URL + 0.002% span] per 20 °C (68 °F)
Static Pressure Effect	Zero error: ± 0.025% URL per 7MPa (1000 psi) The zero error is systematic and can be eliminated by calibrating at the operating static pressure. Span error: Correctable to ± 0.2% of reading per 7 MPa (1000 psi)

NOTES		
Hastelloy is a trademark of the Cabot Corp.	Fluorolube is a trademark of Hooker Chemical Corp.	Smar Pressure Transmitters are protected by US patent number 6,433,791
Monel is a trademark of International Nickel Co.	Halocarbon is a trademark of Halocarbon.	
Viton and Teflon are trademarks of E. I. DuPont de Nemours & Co	Profibus is a trademark of Profibus International	

Ordering Code

MODEL DIFFERENTIAL , FLOW, GAGE, ABSOLUTE AND HIGH STATIC PRESSURE TRANSMITTER										
LD303 PROFIBUS PA										
COD.	Type	Range Limits		Min. Span	Unit	Range Limits		Min. Span	Unit	
		Min.	Max.			Min.	Max.			
D0	Differential and Flow	-1	1	0.05	kPa	-4	4	0.2	inH ₂ O	NOTE: The range can be extended up to 0.75 LRL* and 1.2 URL** with small degradation of accuracy. *LRL = Lower Range Limit. **URL = Upper Range Limit.
D1	Differential and Flow	-5	5	0.13	kPa	-20	20	0.5	inH ₂ O	
D2	Differential and Flow	-50	50	0.42	kPa	-200	200	1.67	inH ₂ O	
D3	Differential and Flow	-250	250	2.08	kPa	-36	36	0.3	psi	
D4	Differential and Flow	-2500	2500	20.83	kPa	-360	360	3	psi	
M0	Gage	-1	1	0.05	kPa	-4	4	0.2	inH ₂ O	
M1	Gage	-5	5	0.13	kPa	-20	20	0.5	inH ₂ O	
M2	Gage	-50	50	0.42	kPa	-200	200	1.67	inH ₂ O	
M3	Gage	-100	250	2.08	kPa	-14.50	36	0.3	psi	
M4	Gage	-100	2500	20.83	kPa	-14.50	360	3	psi	
M5	Gage	-0.1	25	0.21	MPa	-14.50	3600	30	psi	
M6	Gage	-0.1	40	0.33	MPa	-14.50	5800	48.3	psi	
A1	Absolute	0	5	2.00	kPa	0	37	14.8	mmHga	
A2	Absolute	0	50	2.50	kPa	0	7.2	0.36	psia	
A3	Absolute	0	250	5.00	kPa	0	36	0.73	psia	
A4	Absolute	0	2500	20.83	kPa	0	360	3	psia	
A5	Absolute	0	25	0.21	Mpa	0	3600	30	psia	
A6	Absolute	0	40	0.33	MPa	0	5800	48.3	psia	
H2	Differential – High Static Pressure	-50	50	0.42	kPa	-200	200	1.67	inH ₂ O	
H3	Differential – High Static Pressure	-250	250	2.08	kPa	-36	36	0.3	psi	
H4	Differential – High Static Pressure	-2500	2500	20.83	kPa	-360	360	3	psi	
H5	Differential – High Static Pressure	-25	25	0.21	MPa	-3600	-3600	30	psi	
COD. Diaphragm Material and Fill Fluid										
1	316 SST	Silicone Oil (9)	8	Tantalum	Inert Oil Fluorolube (2) (3) (15)	K	Monel 400	Inert Oil Krytox (1) (3) (15)		
2	316 SST	Inert Oil Fluorolube (2) (15)	9	316L SST	Fomblim Oil	M	Monel 400 Gold Plated	Silicone Oil (1) (3) (9)		
3	Hastelloy C276	Silicone Oil (1) (9)	A	Monel 400	Fomblim Oil (1) (3)	P	Monel 400 Gold Plated	Inert Oil Krytox (1) (3) (15)		
4	Hastelloy C276	Inert Oil Fluorolube (1) (2) (15)	D	316L SST	Inert Oil Krytox (3) (15)	Q	316 SST	Inert Oil Halocarbon 4.2 (2) (3) (15)		
5	Monel 400	Silicone Oil (1) (3) (9)	E	Hastelloy C276	Inert Oil Krytox (1) (3) (15)	R	Hastelloy C276	Inert Oil Halocarbon 4.2 (2) (3) (15)		
7	Tantalum	Silicone Oil (3) (9)	G	Tantalum	Inert Oil Krytox (3) (15)	S	Tantalum	Inert Oil Halocarbon 4.2 (2) (3) (15)		
COD. Flange(s), Adapter(s) and Drain/Vent Valves Material										
C	Plated CS (Drain/Vent in Stainless Steel) (16)					M	Monel 400 (1)			
H	Hastelloy C276 (CW-12MW, ASTM-A494) (1)					N	316 SST – CF8M (ASTM A351) (Drain/Vent in Hastelloy C276) (1)			
I	316 SST – CF8M (ASTM A351)					P	316 SST – CF8M (ASTM A351) Flange with PVDF (Kynar) Insert (4) (5) (7) (11)			
COD. Wetted O-Rings Materials										
0	Without O'Rings					K	Kalrez (3)			
B	Buna N					T	Teflon Note: O-Rings are not available on the sides with remote Seals.			
E	Ethylene – Propylene (12)					V	Viton			
COD. Drain/Vent Position										
O	Without Drain/Vent					D	Bottom Note: For better drain/vent operation, vent valves are strongly recommended.			
A	Drain/Vent (Opposite to Process Connection)					U	Top Note: Drain/Vent valve are not available on the sides with remote seals			
COD. Local Indicator										
0	Without Indicator					1	With Digital Indicator			
COD. Process Connections										
0	1/4 - 18 NPT (Without Adapter)					B	High Side : 1/2 - 14 NPT and Low Side : Remote Seal (With Plug) (10) (12)			
1	1/2 - 14 NPT With Adapter					D	High Side : Remote Seal (With Plug) and Low Side – 1/2 - 14 NPT (10) (12)			
3	Remote Seal (With Plug) (3) (8)					F	High Side : 1/2 - 14 NPT and Low Side - Remote Seal (Low Volume Flange) (10) (12)			
5	1/2 - 14 NPT Axial with PVDF Insert (5) (7) (14)					H	High Side : Remote Seal (Low Volume Flange) and Low Side -1/2 – 14 NPT (10) (12)			
9	Remote Seal (Low Volume Flange) (3) (4) (8)					Q	8mm hole without thread. According to DIN 19213 (3)			
T	1/2 - 14 BSP (With Adapter)					Z	User's specification			
V	Manifold Valve Integrated to the Transmitter									
COD. Electrical Connections										
0	1/2 - 14 NPT (17)					A	M20 X 1.5 (19)			
1	3/4 - 14 NPT with 316 SST adapter for 1/2 - 14 NPT (18)					B	PG 13.5 DIN (20)			
2	3/4 - 14 BSP with 316 SST adapter for 1/2 - 14 NPT (6)					Z	User's specification			
3	1/2 - 14 BSP with 316 SST adapter for 1/2 - 14 NPT (6)									
COD. Zero Span Adjustment										
1	With Zero and Span Adjustment									
COD. Mounting Bracket for 2" Pipe or Surface Mounting										
0	Without Bracket					7	Carbon steel bracket. Accessories: 316 SST (16)			
1	Carbon steel bracket and accessories (16)					9	L Type, carbon steel bracket. Accessories: 316 SST (16)			
2	316 SST bracket and accessories					A	Flat, 304 SST bracket and 316 SST accessories			
5	L type, carbon steel bracket and accessories (16)					Z	User's specification			
6	L type, 316 SST bracket and accessories									
COD. Continues next page										

LD303 D2 1 I B U 1 0 0 1 2 *

← TYPICAL MODEL NUMBER

Notes	
(1) Meets NACE MR – 01 – 75/ISO 15156 recommendations.	(11) O’Ring should be Viton or Kalrez.
(2) Not available for absolute models nor vacuum applications.	(12) Not available for range 0.
(3) Not available for range 0 and 1.	(13) Only available for pressure transmitters D4 or H4 and 7/16 UNF or M10 x 1.5 flange thread for fixing accessories.
(4) Not recommended for vacuum service.	(14) Only available for flange with PVDF (Kynar) insert.
(5) Maximum pressure 24 bar (350 psi).	(15) Inert Fluid: Safe for oxygen service.
(6) Options not certified for use in hazardous locations.	(16) Not applicable for saline atmosphere.
(7) Drain/Vent not applicable.	(17) Certificate for use in Hazardous Locations (CEPEL, NEPSI, NEMKO, EXAM, FM, CSA).
(8) For remote seal only 316 SST – CF8M (ASTM A351) flange is available (thread 7/16 UNF).	(18) Certificate for use in Hazardous Locations (CEPEL, CSA).
(9) Silicone Oil is not recommended for oxygen (O2) or Chlorine service.	(19) Certificate for use in Hazardous Locations (CEPEL, NEPSI, NEMKO, EXAM).
(10) Only available for differential pressure transmitters.	(20) Certificate for use in Hazardous Locations (CEPEL, NEPSI, NEMKO, EXAM).

LD303		DIFFERENTIAL, FLOW, GAGE, ABSOLUTE AND HING STATIC PRESSURE TRANSMITTERS (CONTINUATION)	
COD.		Flanges Bolts and Nuts Material	
A0	Plated Carbon Steel (Default) (4)	A5	Hastelloy C276
A1	316 SST		
A2	Carbon Steel (ASTM A193 B7M) (1) (4)		
COD.		Flange Thread for Fixing Accessories (Adapters, Manifolds, Mounting Brackets, etc)	
D0	7/16" UNF (Default)	D2	M12 X 1.75
D1	M10 X 1.5		
COD.		Housing Material (6) (7)	
H0	Aluminum (Default) (IP/TYPE)	H3	316 SST for saline atmosphere (IPW/TYPEX) (5)
H1	316 SST – CF8M (ASTM – A351) IP/TYPE	H4	Copperfree Aluminium (IPW/TYPEX) (5)
H2	Aluminium for saline atmosphere (IPW/TYPEX) (5)		
COD.		Tag Plate	
J0	With tag, when specified (Default)		
J1	Blank		
J2	According to user's notes		
COD.		Identification Plate	
I1	FM: XP, IS, NI, DI	I6	Without Certification
I3	CSA: XP, IS, NI, DI	I7	EXAM (DMT): Group I, M1 Ex-ia
I4	EXAM (DMT): Ex-ia	IF	CEPEL: Ex-d
I5	CEPEL: Ex-d, Ex-ia	IE	NEPSI: Ex-ia
COD.		Painting	
P0	Gray Munsell N 6.5 Polyester	P8	Without Painting
P3	Black Polyester	P9	Blue Safety Epoxy – Electrostatic Painting
P4	White Epoxy	PC	Blue Safety Polyesters – Electrostatic Painting
P5	Yellow Polyester		

LD303 - D211 - BU10 - 012 A0 D0 H0 J0 I6 P0 *

← TYPICAL MODEL NUMBER

Optional Items

* Leave blank for no optional items

Burn-out	BD – Down Scale (Accordance to NAMUR NE43 specification). BU – Up Scale (Accordance to NAMUR NE43 specification).
Special Applications	C1 – Degrease Cleaning (Oxygen or Chlorine Service) (3).
High Performance	L1 – 0.04% accuracy (2).
Square Root Extraction	M3 – With Square Root extraction.
Special Features	ZZ – User’s specification.

Notes													
(1) Meets NACE MR – 01 – 75/ISO 15156 recommendations.	(5) IP66/68W tested for 200 hours according to NBR 8094 / ASTM B 117 standard.												
(2) Only available for differential and gage pressure models.	(6) IPX8 tested in 10 meters of water column for 24 hours.												
(3) Degrease cleaning not available for carbon steel flanges.	(7) Ingress Protection:												
(4) Not applicable for saline atmosphere.													
	<table border="1"> <thead> <tr> <th>Product</th> <th>CEPEL</th> <th>NEMKO/EXAM</th> <th>FM</th> <th>CSA</th> <th>NEPSI</th> </tr> </thead> <tbody> <tr> <td>LD300</td> <td>IP66/68W</td> <td>IP66/68W</td> <td>Type4X/6(6P)</td> <td>Type4X</td> <td>IP67</td> </tr> </tbody> </table>	Product	CEPEL	NEMKO/EXAM	FM	CSA	NEPSI	LD300	IP66/68W	IP66/68W	Type4X/6(6P)	Type4X	IP67
Product	CEPEL	NEMKO/EXAM	FM	CSA	NEPSI								
LD300	IP66/68W	IP66/68W	Type4X/6(6P)	Type4X	IP67								

MODEL	FLANGED PRESSURE TRANSMITTERS										
LD303	PROFIBUS PA										
COD.	Range Limits		Min. Span	Unit	Range limits		Min. Span	Unit	Note: The range can be extended up to 0.75 LRL and 1.2 URL with small degradation of accuracy. The upper range value must be limited to the flange rating.		
	Min.	Max.			Min.	Max.					
L2	-50	50	1.25	kPa	-200	200	5	inH ₂ O			
L3	-250	250	2.08	kPa	-36	36	0.3	psi			
L4	-2500	2500	20.83	kPa	-360	360	3	psi			
L5	-25000	25000	208.3	kPa	-3625	3625	30.2	psi			
COD. Diaphragm material and Fill Fluid (Low Side)											
1	316L SST	Silicone Oil (2)	7	Tantalum	Silicone Oil (2)	E	Hastelloy C276	Inert Oil Krytox (1)(19)	Q	316L SST	Inert Oil Halocarbon 4.2 (19)
2	316L SST	Inert Oil Fluorolube(3)(19)	8	Tantalum	Inert Oil Fluorolube (3) (19)	G	Tantalum	Inert Oil Krytox (19)	R	Hastelloy C276	Inert Oil Halocarbon 4.2 (1) (19)
3	Hastelloy C276	Silicone Oil (1) (2)	9	316L SST	Fomblim Oil	K	Monel 400	Inert Oil Krytox (1) (19)	S	Tantalum	Inert Oil Halocarbon 4.2 (19)
4	Hastelloy C276	Inert Oil Fluorolube (1)(3)(19)	A	Monel 400	Fomblim Oil (1)	M	Monel 400 Gold Plated	Silicone Oil (1) (2)			
5	Monel 400	Silicone Oil (1) (2)	D	316L SST	Inert Oil Krytox (19)	P	Monel 400 Gold Plated	Inert Oil Krytox (1) (19)			
COD. Flange, Adapter and Drain/Vent Valves material (Low Side)											
A	304L SST					M	Monel 400 (1)				
C	Plated CS (Drain/Vent in Stainless Steel) (20)					N	316 SST – CF8M (ASTM – A351) (Drain/Vent in Hastelloy C276) (1)				
H	Hastelloy C276 (CW – 12MW, ASTM – A494) (1)					P	316 SST – CF8M (ASTM – A351) Flange with PVDF (Kynar) insert (3) (4) (5)				
I	316 SST – CF8M (ASTM – A351)										
COD. Wetted O'Ring Material (Low Side)											
0	Without O'Rings					K	Kalrez				
B	Buna-N					T	Teflon				
E	Ethylene - Propylene					V	Viton				
Note: O'rings are not available on the sides with remote seals.											
COD. Drain/Vent Position (Low Side)											
0	Without Drain/Vent					D	Bottom				
A	Drain/Vent (Opposite to Process Connection)					U	Top				
Note: For better Drain/Vent operation, vent valves are strongly recommended. Drain/Vent valve are not available on the sides with remote seals.											
COD. Local Indicator											
0	Without Indicator					1	With Digital indicator				
COD. Process Connection (Low Side)											
0	1/4 - 18 NPT (Without Adapter)					T	1/2 14 BSP (With Adapter)				
1	1/2 - 14 NPT (With Adapter)					U	Low Volume Flange For Level Welded				
3	Remote Seal (With Plug) (7)					V	Without Connection (Mounting With Gage Flange)				
5	1/2 - 14 NPT Axial with PVDF Insert (3) (4) (6)					W	Without Connection (Absolut Reference)				
9	Remote Seal (Low Volume Flange) (3) (7)										
COD. Electrical Connection											
0	1/2 - 14 NPT (25)					A	M20 x 1.5 (26)				
1	3/4 - 14 NPT (with 316 SST adapter for 1/2 - 14 NPT) (22)					B	PG 13.5 DIN (27)				
2	3/4 - 14 BSP (with 316 SST adapter for 1/2 - 14 NPT) (9)					Z	User's specification				
3	1/2 - 14BSP (with 316 SST adapter for 1/2 - 14 NPT) (9)										
COD. Zero and Span Adjust											
1	With Zero and Span Adjustment										
COD. Process Connection											
U	1" 150 # (ANSI B16.5) (30)			C	3" 600 # (ANSI B16.5)			S	JIS 40A 20K (23)		
V	1" 300 # (ANSI B16.5) (30)			N	3" 600 # (ANSI B16.5 RTJ)			F	JIS 50A 10K (23)		
W	1" 600 # (ANSI B16.5) (30)			3	4" 150 # (ANSI B16.5)			T	JIS 50A 40K (23)		
O	1.1/2" 150 # (ANSI B16.5)			4	4" 300 # (ANSI B16.5)			K	JIS 50A 20K (23)		
P	1.1/2" 300 # (ANSI B16.5)			D	4" 600 # (ANSI B16.5)			G	JIS 80A 10K (23)		
Q	1.1/2" 600 # (ANSI B16.5)			5	DN 25 PN 10/40 (30)			L	JIS 80A 20K (23)		
9	2" 150 # (ANSI B16.5)			R	DN 40 PN 10/40			H	JIS 100A 10K (23)		
A	2" 300 # (ANSI B16.5)			E	DN 50 PN 10/40			M	JIS 100A 10K (23)		
B	2" 600 # (ANSI B16.5)			6	DN 80 PN 10/40			Z	User's specification		
1	3" 150 # (ANSI B16.5)			7	DN 100 PN 10/16						
2	3" 300 # (ANSI B16.5)			8	DN 100 PN 25/40						
COD. Type and Flange Material (Level Tap)											
2	316L SST (Integral Flange)			4	304 SST (Slip-on Flange)			6	Carbon Steel (Slip-on Flange)		
3	Hastelloy C276 (Integral Flange)			5	316 SST (Slip-on Flange)			Z	User's specification		
COD. Extension Length											
0	0 mm (0")			3	150 mm (6")			Note: Extension Material 316L SST			
1	50 mm (2")			4	200 mm (8")						
2	100 mm (4")			Z	User's specification						
COD. Diaphragm Material / Extension (Level Tap)											
A	304L SST / 304L SST					6	316L SST with Teflon Lining (For 2"and 3")				
1	316L SST / 316 SST					7	316L SST Gold plated				
2	Hastelloy C276 / 316 SST					B	Tantalum with Teflon Lining				
3	Monel 400 / 316 SST					L	316L SST Halar Plated (18)				
4	Tantalum / 316 SST (10)					C	Hastelloy Teflon Plated				
5	Titanium / 316 SST (10)										
COD. Fill Fluid											
1	DC – 200/20 Silicone Oil					G	Glycerin (6)				
3	DC704 Silicone Oil					B	Fomblim 06/06				
2	MO – 10 Fluorolube Oil (8)					H	Halocarbon 4.2				
4	Krytox Oil					T	Sytherm 800 Oil				
N	Neobee M20 Propylene Glycol Oil										
COD. Housing Material											
0	Without Gaskets (12)					3	Super Duplex (UNS 32750) (11)				
1	316 SST					4	Duplex (UNS 31803) (11)				
2	Hastelloy C276					5	Stainless Steel 304L (11)				
COD. Gasket Material											
0	Without gasket					C	Copper				
T	Teflon (PTFE)					I	316 L SST				
G	Grafoil (Flexible lead)										
COD. Continues Next Page											

LD303 L2 1 I B U 1 0 0 1 1 2 2 1 1 1 1 T *

← TYPICAL MODEL NUMBER

LD303		FLANGED PRESSURE TRANSMITTERS (CONTINUATION)						
COD.		Flanges Bolts and Nuts Material						
A0	Plated Carbon Steel (Default) (20)			A2	Carbon Steel (ASTM A193 B7M) (1) (20)			
A1	316 SST			A5	Hastelloy C276			
COD.		Flange Thread for Fixing Accessories (Adapters, Manifolds, Mounting Brackets, etc)						
D0	7/16" UNF (Default)			D1	M10 X 1.5 Thread		D2	M12 X 1.75
COD.		Flange Facing Finish (16)						
Q0	Raised Face – RF (Default)			Q2	Ring Joint Face – RTJ (Only available for ANSI standard flange) (15)		Q4	Grooved Face (11)
Q1	Flat Face – FF			Q3	Tongue Face (11)			
COD.		Housing Material (28) (29)						
H0	Aluminum (Default) (IP/TYPE)			H3	316 SST (IPW/TYPEX) (21)			
H1	316 SST – CF8M ASTM – A351 (IP/TYPE)			H4	Copperfree Aluminium (IPW/TYPEX) (21)			
H2	Aluminium (IPW/TYPEX) (21)							
COD.		Tag Plate						
J0	With tag, when specified (Default)			J1	Blank		J2	According to user's notes
COD.		Identification Plate						
I1	FM: XP, IS, NI, DI		I5	CEPEL: Ex-d, Ex-ia		IF	CEPEL: Ex-d	
I3	CSA: XP, IS, NI, DI		I6	Without Certification		IM	BDSR-GOST: Ex-d, Ex-ia	
I4	EXAM (DMT): Ex-ia		I7	EXAM (DMT): Group I, M1 Ex-ia				
COD.		Painting						
P0	Gray Munsell N6,5 Polyesters			P8	Without Painting			
P3	Black Polyester			P9	Blue Safety Epoxy – Electrostatic Painting			
P4	White Epoxy			PC	Blue Safety Polyesters – Electrostatic Painting			
P5	Yellow Polyester							

LD303-L2L-BU10-01-12211 A0 D0 Q0 H0 J0 I6 P0 * ← TYPICAL MODEL NUMBER

Optional Items

* Leave blank for no optional items

Burn-out	BD - Down Scale (Accordance to NAMUR NE43 specification)	BU - Up Scale (Accordance to NAMUR NE43 specification).
Special Applications	C1 - Degrease Cleaning (Oxygen or Chlorine Service (13))	C2 - For vacuum application.
Special Features	ZZ - User's specification.	
Gasket Connection	U0 - With one Flush Connection ¼" NPT (if supplied with gasket) U1 - With two Flush Connections ¼" NPT per 180 °C U2 - With two Flush Connections ¼" NPT per 90 °C U3 - With two Flush Connections ½" NPT - 14 NPT per 180 °C (with cover) U4 - Without Gasket Connection	
Isolator Kit (14)	K0 - Without Kit	K1 - With Kit
Diaphragm Thickness	N0 - Default (24)	N1 - 0.1mm (11)

NOTES

- (1) Meets NACE MR – 01 – 75/ISO 15156 recommendations.
- (2) Silicone Oils not recommendations for Oxygen (O₂) or Chlorine service.
- (3) Not applicable for vacuum service.
- (4) Drain/Vent not applicable.
- (5) O'Ring should be Viton or Kalrez.
- (6) Maximum pressure 24 bar.
- (7) For Remote Seal only 316 SST - CF8M (ASTM A3510 flange is available (thread M12).
- (8) Fluorolube fill fluid is not available for Monel diaphragm.
- (9) Options not certified for use in hazardous locations.
- (10) Attention, check corrosion rate for the process, tantalum plate 0.1 mm, AISI 316L extension 3 to 6mm.
- (11) Item by inquiry.
- (12) Supplied without Gasket.
- (13) Degreaser's cleaning is not available for carbon steel flanges
- (14) The insulator kit is applicable with Raised Face (H0) and Smooth Face (H1) with Gasket material.
T(Teflon) and only for the following models:
- For models with extension the Gasket T (Teflon) it has special share.
- (15) Gasket for housing, available only in Stainless 316.
- (16) Finishing flange faces:
ANSI B 16.5 / MSS-SP6:
- Raised or Smooth Face with gooved lining: 3.2 to 6.3 µm Ra (125 a 250 µ" AA);
Small or Large Tongue Face and Small or Large Groove with smooth finishing
not exceeding: 3.2 µm Rt (125 µ" AA);
RTJ ANSI B 16.20 / MSS-SP6:
- Smooth finishing not exceeding: 1.6 µm Rt (63 µ" AA);
DIN EN-1092-1:
- Grooved finishing "B1" (PN 10 a PN40): 3.2 a 12.5 µm Ra (125 a 500 µ" AA);
Smooth finishing "B2" (PN 63 a PN100), "C" (Tongue) e "D" (Groove): 0.8 a 3.2 µm Ra (32 a 125 µ" AA).

- DIN 2501 (DIN 2526):
- Smooth finishing "E" (PN 160 a PN250): Rz = 16 (3.2 µm Ra (125 µ" AA).
Standard JIS B2201
Grooved finishing 3.2 a 6.3 µm Ra (125 a 250 µ" AA).
- (17) Range of application of temperature from -40 °C to 150 °C.
- (18) Applicable only to:
- Thickness of steel: 0.05 mm
- Diameter/capillary length:
2" ANSI B 16.5 DN 50 DIN, JIS 50 A, for seals up to 3 meters of capillary and level models (by inquiry).
3" ANSI B 16.5 DN 80 DIN, JIS 80 A, for seals up to 5 meters of capillary and level models.
- Faces: RF and FF;
- Temperature Range: +10 °C to 100 °C
+ 101 to 150 ° C (by inquiry)
- Not applicable for diaphragm thickness;
- Not applicable for use with gaskets.
- (19) Inert Fluid: Oxygen Compatibility, safe for oxygen service.
- (20) Not applicable for saline atmosphere.
- (21) IP66/68W tested for 200 hours according to NBR 8094 / ASTM B 117 standard.
- (22) Certificate for use in Hazardous Locations (CEPEL, CSA).
- (23) Not available for slip-on flange.
- (24) Diaphragms of Titanium and Monel available only in 0.1 mm, and diaphragms of Tantalum only in 0.075 mm.
- (25) Certificate for use in Hazardous Locations (CEPEL, NEPSI, NEMKO, EXAM, FM, CSA).
- (26) Certificate for use in Hazardous Locations (CEPEL, NEPSI, NEMKO, EXAM).
- (28) Certificate for use in Hazardous Locations (CEPEL, NEPSI, NEMKO, EXAM).
- (28) IPX8 tested in 10 meters of water column for 24 hours.
- (29) Ingress Protection:

Product	CEPEL	NEMKO/EXAM	FM	CSA	NEPSI
LD300	IP66/68W	IP66/68W	Type4X/6(6P)	Type4X	IP67

- (30) Not available for integral flange.

MODEL	SANITARY PRESSURE TRANSMITTERS											
LD303	PROFIBUS PA											
CODE	Range Limits		Min. Span	Unit	Range Limits		Min. Span	Unit	Note: The range can be extended up to 0.75 LRL and 1.2 URL with small degradation of accuracy. The upper range value must be limited to the connection.			
	Min.	Max.			Min.	Max.						
S2	-50	50	1.25	kPa	-200	200	5	inH ₂ O				
S3	-250	250	2.08	kPa	-36	36	0.3	psi				
S4	-2500	2500	20.83	kPa	-360	360	3	psi				
S5	-25000	25000	208.30	kPa	-3625	3625	30.2	psi				
COD Diaphragm Material and Fill Fluid (Low Side)												
1	316L SST	Silicone Oil (2)	7	Tantalum	Silicone Oil (2)	E	Hastelloy C276	Inert Krytox Oil (1) (17)	Q	316L SST	Inert Haloc 4.2 Oil (17)	
2	316L SST	Inert Fluorolube Oil (3) (17)	8	Tantalum	Inert Fluorolube Oil (3) (17)	G	Tantalum	Inert Krytox Oil (17)	R	Hastelloy C276	Inert Haloc 4.2 Oil (1) (17)	
3	Hastelloy C276	Silicone Oil (1) (2)	9	316L SST	Fomblim Oil	K	Monel 400	Inert Krytox Oil (1) (17)	S	Tantalum	Inert Haloc 4.2 Oil (17)	
4	Hastelloy C276	Inert Fluorolube Oil (1) (3) (17)	A	Monel 400	Fomblim Oil (1)	M	Monel 400 Gold Plated	Silicone Oil (1) (2)				
5	Monel 400	Silicone Oil (1) (2)	D	316L SST	Inert Krytox Oil (17)	P	Monel 400 Gold Plated	Inert Krytox Oil (1) (17)				
CODE Flange(s), Adapter (s) and Drain Valve(s) Material (Low Side)												
C	Plated CS (Drain in Stainless Steel) (15)						M	Monel 400 (1)				
H	Hastelloy C276 (CW-12MW, ASTM - A494) (1)						N	316 SST – CF8M (ASTM – A351) (Drain in Hastelloy C276) (1)				
I	316 SST – CF8M (ASTM - A351)						P	316 SST – CF8M (ASTM – A351) Flange with PVDF (Kynar) insert (3) (4) (5)				
CODE Wetted O-Ring Material (Low Side)												
0	Without O-Ring						K	Kalrez				
B	Buna-N						T	Teflon (Approved 3A)				
E	Ethylene - Propylene						V	Viton (Approved 3A)				
CODE Drain Position (Low Side)												
0	Without Drain						D	Bottom				
A	Drain (Opposite to process connection)						U	Top				
CODE Local Indicator												
0	Without Indicator						1	With Digital Indicator				
CODE Process Connection (Low Side)												
0	1/4 - 18 NPT (Without Adapter)						T	1/2-14 BSP (With Adapter)				
1	1/2 - 14 NPT (With Adapter)						U	Low Volume Flange For Level Welded				
3	Remote Seal (With Plug – Vacuum Assembly) (7)						V	Without Connection (Mounting With Gage Flange)				
5	1/2 - 14 NPT Axial with PVDF insert (3) (4) (6)						W	Without Connection (Absolut Reference)				
9	Remote Seal (Low Volume Flange) (3) (7)											
CODE Electrical Connection												
0	1/2 - 14 NPT (18)						A	M20 X 1.5 (20)				
1	3/4 - 14 NPT (With 316 SST adapter for 1/2 - 14 NPT) (19)						B	PG 13.5 DIN (21)				
2	3/4 - 14 BSP (With 316 SST adapter for 1/2 - 14 NPT) (9)						Z	User's Specification				
3	1/2 - 14 BSP (With 316 SST adapter for 1/2 - 14 NPT) (9)											
CODE Zero and Span Adjust												
1	With Local Adjustment											
CODE Process Connection												
8	Threaded DN25 DIN 11851 – with extension (10)						E	Threaded SMS 2" – without extension (10)				
9	Threaded DN40 DIN 11851 - with extension (10)						M	Threaded SMS 3" - with extension (10)				
H	Threaded DN40 DIN 11851 – without extension (10)						1	Threaded SMS 3" - without extension (10)				
V	Threaded DN50 DIN 11851 - with extension (10)						F	Tri-Clamp 1 1/2" – without extension				
U	Threaded DN50 DIN 11851 - without extension (10)						Q	Tri-Clamp 1 1/2" HP (High Pressure) - without extension (8)				
X	Threaded DN80 DIN 11851 - with extension (10)						6	Tri-Clamp 2" - with extension				
W	Threaded DN80 DIN 11851 - without extension (10)						D	Tri-Clamp 2" – without extension				
4	Threaded IDF 2" - with extension (10)						N	Tri-Clamp 2" HP (High Pressure) - with extension (8)				
B	Threaded IDF 2" – without extension (10)						P	Tri-Clamp 2" HP (High Pressure) – without extension (8)				
K	Threaded IDF 3" - with extension (10)						I	Tri-Clamp 3" - with extension				
3	Threaded IDF 3" - without extension (10)						G	Tri-Clamp 3" – without extension				
5	Threaded RJT 2" - with extension (10)						J	Tri-Clamp 3" HP (High Pressure) - with extension (8)				
C	Threaded RJT 2" - without extension (10)						R	Tri-Clamp 3" HP (High Pressure) – without extension o (8)				
L	Threaded RJT 3" - with extension (10)						A	Tri-Clamp DN50 - with extension				
2	Threaded RTJ 3" - without extension (10)						O	Tri-Clamp DN50 HP (High Pressure) - with extension (8)				
S	Threaded SMS 1 1/2" – without extension (10)						T	Tri-Clamp DN50 – without extension				
7	Threaded SMS 2" - with extension (10)						Z	User's specification				
CODE Flange Material (Level Tap)												
2	316L SST											
Z	User's Specification											
CODE Diaphragm Material												
H	Hastelloy C276											
I	316L SST											
COD Fill Fluid												
S	DC 200 – silicone oil						G	Glycerin + Water (12)				
D	DC 704 – silicone oil						B	Fomblim 06/06				
F	Fluorolube MO-10						K	Krytox 1506				
T	Syltherm 800						H	Halocarbom 4.2				
N	Neobee M20 (Approved 3A) (11) (22)											
CODE Wet O-ring												
0	Without O-ring											
T	Teflon											
B	Buna-N											
V	Viton (Approved 3A) (11) (22)											
CODE Tank Adapter												
0	Without Tank Adapter											
1	With Tank Adapter in 316 SST											
CODE Tri-Clamp												
0	Without Tri-Clamp											
2	With Tri-Clamp in 304 SST											
CODE Continues next page												

LD303 S2 1 I B U 1 0 0 1 A 2 I S T 1 2 *

* Leave it blank when there are not optional items.

LD303		SANITARY PRESSURE TRANSMITTERS (CONTINUATION)						
CODE		Flange Bolts and Nuts Material						
A0	Plated Carbon Steel (Default) (15)			A2	Carbon Steel (ASTM A193 B7M) (1) (15)			
A1	316 SST			A5	Hastelloy C276			
CODE		Flange Thread for Fixing Accessories (Adapters, Manifolds, Mounting Brackets, etc)						
D0	7/16" UNF (Default)			D2	M12 X 1.75			
D1	M10 X 1.5 Thread							
CODE		Housing Material (23) (24)						
H0	Aluminum (Default) (IP/TYPE)			H3	316 SST for Saline Atmosphere (IPW/TYPEX) (16)			
H1	316 SST – CF8M (ASTM – A351) (IP/TYPE)			H4	Copper Free Aluminium (IPW/TYPEX) (16)			
H2	Aluminum for Saline Atmosphere (IPW/TYPEX) (16)							
CODE		Tag Plate						
J0	With tag, when specified (Default)			J1	Blank		J2	According to user's notes
CODE		Identification Plate						
I1	FM: XP, IS, NI, DI			I6	Without Certification			
I3	CSA: XP, IS, NI, DI			I7	EXAM (DMT): Class I, M1 Ex-ia			
I4	EXAM (DMT): Ex-ia			IF	CEPEL: Ex-d			
I5	CEPEL: Ex-d, Ex-ia							
CODE		Painting						
P0	Gray Munsell N 6.5 Polyester			P8	Without Painting			
P3	Black Polyester			P9	Safety Blue Epoxy – Electrostatic Painting			
P4	White Epoxy			PC	Safety Polyester - Electrostatic Painting			
P5	Yellow Polyester							

LD303-S211- BU10-01A2- IST12	A0	D0	H0	J0	I6	P0	*
------------------------------------	----	----	----	----	----	----	---

← TYPICAL MODEL NUMBER

Optional Items

* Leave it blank when there are not optional items.

Burn-out	BD - Down Scale (Accordance to NAMUR NE43 specification) BU - Up Scale (Accordance to NAMUR NE43 specification)
Special Procedures	C1 - Degrease Cleaning (Oxygen or Chlorine Service) (13) C2 - For Vacuum Application C4 - Polishing of the wet parts according to 3A Certification (11) (12)
Special Features	ZZ - User's Specification
Diaphragm Thickness	N0 – Default N1 - 0.1mm (12)

Note													
<p>(1) Meets NACE MR-01-75/ISO 15156 recommendations. (2) Silicone oil not recommended for Oxygen (O2) or Chlorine Service. (3) Not applicable for vacuum service. (4) Drain not applicable. (5) O-Ring material must be of Viton or Kalrez. (6) Maximum pressure 24 bar. (7) For remote seal is only available flange in 316 Stainless Steel - CF8M (ASTM A351) (thread M12). (8) HP – High Pressure. (9) Options not certified for use in hazardous locations. (10) Not available for Tri-clamp. (11) 3A-7403 Standard: - Neobee M2O Fill Fluid - Finishing wet Face: 0.8 µm Ra (32 µ" AA) - Wet O-Ring: Viton (12) Item by inquiry. (13) Degrease cleaning is not available for Carbon Steel Flanges. (14) Temperature application range: -40 to 140 °C.</p>	<p>(15) Not applicable for saline atmosphere. (16) IP66/68W tested for 200 hours according to NBR 8094 / ASTM B 117 standard. (17) The inert fluid guarantees safety for Oxygen (O₂) service. (18) Certificate for use in Hazardous Locations (CEPEL, NEPSI, NEMKO, EXAM, FM, CSA). (19) Certificate for use in Hazardous Locations (CEPEL, CSA). (20) Certificate for use in Hazardous Locations (CEPEL, NEPSI, NEMKO, EXAM). (21) Certificate for use in Hazardous Locations (CEPEL, NEPSI, NEMKO, EXAM). (22) Compliant with 3A-7403 standard for food and other applications where sanitary connections are required. (23) IPX8 tested in 10 meters of water column for 24 hours. (24) Ingress Protection:</p> <table border="1" style="width: 100%; text-align: center;"> <thead> <tr> <th>Product</th> <th>CEPEL</th> <th>NEMKO/EXAM</th> <th>FM</th> <th>CSA</th> <th>NEPSI</th> </tr> </thead> <tbody> <tr> <td>LD300</td> <td>IP66/68W</td> <td>IP66/68W</td> <td>Type4X/6(6P)</td> <td>Type4X</td> <td>IP67</td> </tr> </tbody> </table>	Product	CEPEL	NEMKO/EXAM	FM	CSA	NEPSI	LD300	IP66/68W	IP66/68W	Type4X/6(6P)	Type4X	IP67
Product	CEPEL	NEMKO/EXAM	FM	CSA	NEPSI								
LD300	IP66/68W	IP66/68W	Type4X/6(6P)	Type4X	IP67								

CERTIFICATIONS INFORMATION

European Directive Information

Consult www.Smar.com for the EC declarations of conformity and certificates.

Authorized representative/importer located within the Community:

Smar Europe BV De Oude Wereld 116 2408 TM Alphen aan den Rijn Netherlands

ATEX Directive 2014/34/EU - "Equipment for explosive atmospheres" (applicable from 20 April 2016)

The EC-Type Examination Certificate is released by DNV GL Presafe AS (CE2460) and DEKRA EXAM GmbH (CE0158).

Designated certification body that monitors manufacturing and released QAN (Quality Assurance Notification) and QAR (Quality Assessment Report) is Nemko AS (CE0470).

LVD Directive 2014/35/EU – "Low Voltage" (applicable from 20 April 2016)

According to the LVD directive Annex II, electrical equipment for use in an explosive atmosphere is outside the scope of this directive.

According to IEC standard: IEC 61010-1:2010 - Safety requirements for electrical equipment for measurement, control, and laboratory use - Part 1: General requirements.

PED Directive 2014/68/EU - "Pressure Equipment" (applicable from 19 July 2016)

This product is in compliance with Article 4 paragraph 3 of the Pressure Equipment Directive 2014/68/EU and was designed and manufactured in accordance with the sound engineering practice. This equipment cannot bear the CE marking related to PED compliance. However, the product bears the CE marking to indicate compliance with other applicable European Community Directives.

ROHS Directive 2011/65/EU - "Restriction of the use of certain hazardous substances in electrical and electronic equipment"

According to ROHS directive Article 2, paragraph 2, member states shall provide that EEE that was outside the scope of Directive 2002/95/EC, but which would not comply with this Directive, may nevertheless continue to be made available on the market until 22 July 2019.

EMC Directive 2014/30/EU - "Electromagnetic Compatibility" (applicable from 20 April 2016)

For products evaluation the standard IEC 61326-1:2013 were consulted and to comply with the EMC directive the installation must follow these special conditions:

Use shielded, twisted-pair cable for powering the instrument and signal wiring.

Keep the shield insulated at the instrument side, connecting the other one to the ground.

Hazardous locations general information

Ex Standards:

IEC 60079-0 General Requirements

IEC 60079-1 Flameproof Enclosures "d"

IEC 60079-7 Increased Safe "e"

IEC 60079-11 Intrinsic Safety "i"

IEC 60079-18 Encapsulation "m"

IEC 60079-26 Equipment with equipment protection level (EPL) Ga

IEC 60079-31 Equipment dust ignition protection by enclosure "t"

IEC 60529 Classification of degrees of protection provided by enclosures (IP Code)

IEC 60079-10 Classification of Hazardous Areas

IEC 60079-14 Electrical installation design, selection and erection

IEC 60079-17 Electrical Installations, Inspections and Maintenance

ISO/IEC80079-34 Application of quality systems for equipment manufacture

Warning:

Explosions could result in death or serious injury, besides financial damage.

Installation of this instrument in hazardous areas must be in accordance with the local standards and type of protection. Before proceedings with installation make sure that the certificate parameters are in accordance with the classified hazardous area.

Maintenance and Repair

The instrument modification or replaced parts supplied by any other supplier than authorized representative of Smar is prohibited and will void the Certification.

Marking Label

The instrument is marked with type of protection options. The certification is valid only when the type of protection is indicated by the user. Once a particular type of protection is installed, do not reinstall it using any other type of protection.

Intrinsic Safety / Non Incendive application

In hazardous areas with intrinsic safety or or non-incendive requirements, the circuit entity parameters and applicable installation procedures must be observed.

The instrument must be connected to a proper intrinsic safety barrier. Check the intrinsically safe parameters involving the barrier and equipment including the cable and connections. Associated apparatus ground bus shall be insulated from panels and mounting enclosures. Shield is optional, when using shielded cable, be sure to insulate the end not grounded.

Cable capacitance and inductance plus Ci and Li must be smaller than Co and Lo of the Associated Apparatus. It is recommended do not remove the housing covers when powered on.

Explosionproof / Flameproof application

Only use Explosionproof/Flameproof certified Plugs, Adapters and Cable glands.

The electrical connections entries must be connected using a conduit with sealed unit or closed using metal cable gland or metal blanking plug with at least IP66.

Do not remove the housing covers when powered on.

Enclosure

The electronic housing and sensor threads installed in hazardous areas must have a minimum of 6 fully engaged threads.

The covers must be tightening with at least 8 turns, to avoid the penetration of humidity or corrosive gases, and until it touches the housing. Then, tighten more 1/3 turn (120°) to guarantee the sealing.

Lock the housing and covers using the locking screw.

Degree of Protection of enclosure (IP)

IPx8: Second numeral meaning continuous immersion in water under special condition defined as 10m for a period of 24 hours (Ref: IEC60529).

IPW/ TypeX: Supplementary letter W or X meaning special condition defined as saline environment tested in saturated solution of NaCl 5% w/w at 35°C for a period of 200 hours (Ref: NEMA 250/ IEC60529).

For enclosure with IP/IPW/TypeX applications, all NPT threads must apply a proper water-proof sealant (a non-hardening silicone group sealant is recommended).

Hazardous Locations Approvals

FM Approvals

FM 4Y3A4.AX

IS Class I, II, III Division 1, Groups A, B, C and D, E, F, G

XP Class I, Division 1, Groups A, B, C, D

DIP Class II, III Division 1, Groups E, F, G

NI Class I, Division 2, Groups A, B, C, D

Option: Type 4X/6/6P or Type 4/6/6P

Entity Parameters Fieldbus Power Supply Input (report 3015629):

Vmax = 24 Vdc, Imax = 250 mA, Pi = 1.2 W, Ci = 5 nF, Li = 12 uH

Vmax = 16 Vdc, Imax = 250 mA, Pi = 2 W, Ci = 5 nF, Li = 12 uH

Temperature Class T4

Ambient Temperature: 60°C (-20 to 60 °C)

Overpressure Limits: 5800 psi (report 3024465)

The range H2 to H5 are similar to D2 to D5, the H ranges are differential type with high static pressure feature.

The ranges H, A5, A6, M5 and M6 need parback for correct and safe operation.

Drawing 102A-0078, 102A-1220, 102A-1343, 102A-1642, 102A-1643

ATEX DNV GL Presafe AS

Explosion Proof (PRESAFE 18 ATEX 12410X)

II 2 G Ex db IIC T6 Gb

Ta -20 °C to +60 °C

Options: IP66/68W or IP66/68
 Special Conditions for Safe Use

Repairs of the flameproof joints must be made in compliance with the structural specifications provided by the manufacturer. Repairs must not be made on the basis of values specified in tables 1 and 2 of EN/IEC 60079-1.

The Essential Health and Safety Requirements are assured by compliance with:
 EN IEC 60079-0:2018 General Requirements
 EN 60079-1:2014 Flameproof Enclosures “d”

Drawing 102A-1467, 102A-1523

IECEX DNV GL Presafe AS

Explosion Proof (IECEX PRE 18.0031X)
 Ex db IIC T6 Gb
 Ta -20 °C to +60 °C
 Options: IP66/68W or IP66/68

Special Conditions for Safe Use

Repairs of the flameproof joints must be made in compliance with the structural specifications provided by the manufacturer. Repairs must not be made on the basis of values specified in tables 1 and 2 of EN/IEC 60079-1.

The Essential Health and Safety Requirements are assured by compliance with:
 IEC 60079-0:2017 General Requirements
 IEC 60079-1:2014-06 Equipment protection by flameproof enclosures “d”

Drawing 102A-2115, 102A-2116

ATEX DEKRA Testing and Certification GmbH

Intrinsic Safety (DMT 00 ATEX E 067)
 Ex I M1 Ex ia I Ma
 Ex II 1/2 G Ex ia IIC T4/T5/T6 Ga/Gb

FISCO Field Device

Supply circuit for the connection to an intrinsically safe FISCO fieldbus-circuit:

Ui = 24 Vdc, Ii = 380 mA, Pi = 5.32 W, Ci ≤ 5nF, Li = Neg

Parameters of the supply circuit comply with FISCO model according to Annex G EN 60079-11:2012, replacing EN 60079-27: 2008.



Ambient Temperature:
 -40°C ≤ Ta ≤ +60°C (T4)
 -40°C ≤ Ta ≤ +50°C (T5)
 -40°C ≤ Ta ≤ +40°C (T6)

The Essential Health and Safety Requirements are assured by compliance with:
 EN 60079-0:2012 +A11:2013 General Requirements
 EN 60079-11:2012 Intrinsic Safety “i”
 EN 60079-26:2015 Equipment with equipment protection level (EPL) Ga

Drawing 102A-1467, 102A-1523, 102A-1469, 102A-1525

CEPEL (Centro de Pesquisa de Energia Elétrica)

Segurança Intrínseca (CEPEL 96.0075X)

 <p>CEPEL 96.0075X Equipamento de campo FISCO Ex ia IIC T* Ga/Gb</p>		 <p>CEPEL 95.0075X Equipamento de campo FISCO Ex ia IIIC T* Da/Db</p>	
IP66W/IP68W (aço inox e alumínio Copper Free)	IP66/IP68 (alumínio)	IP66W/IP68W (aço inox e alumínio Copper Free)	IP66/IP68 (alumínio)
Ui = 30 V Ii = 380 mA Pi = 5,32 W Ci = 5,0 nF Li = desp		Ui = 30 V Ii = 380 mA Pi = 5,32 W Ci = 5,0 nF Li = desp	
Tamb: -20 °C a +50 °C para T5 Tamb: -20 °C a +65 °C para T4		Tamb: -20 °C a +50 °C para T100 °C Tamb: -20 °C a +65 °C para T135 °C	

Prova de Explosão (CEPEL 98.0054)

 <p>Segurança</p> <p>CEPEL 98.0054</p> <p>Ex db IIC T6 Ga/Gb</p> <p>Ex tb IIIC T85 °C Db</p>	
IP66W/IP68W	IP66/IP68
(aço inox e alumínio Copper Free)	(alumínio)

Observações:

A validade deste Certificado de Conformidade está atrelada à realização das avaliações de manutenção e tratamento de possíveis não conformidades, de acordo com as orientações do Cepel, previstas no Regulamento de Avaliação da Conformidade. Para verificação da condição atualizada de regularidade deste Certificado de Conformidade deve ser consultado o banco de dados de produtos e serviços certificados do Inmetro.

O número do certificado é finalizado pela letra "X" para indicar que para a versão do Transmissor de pressão, intrinsecamente seguro, modelos LD292, LD293, LD302 e LD303 equipado com invólucro fabricado em liga de alumínio, somente pode ser instalado em "Zona 0", se durante a instalação for excluído o risco de ocorrer impacto ou fricção entre o invólucro e peças de ferro/aço.

O A tampa do invólucro possui uma plaqueta de advertência com a seguinte inscrição: "ATENÇÃO - NÃO ABRA ENQUANTO ENERGIZADO", ou similar tecnicamente equivalente.

O produto adicionalmente marcado com a letra suplementar "W" indica que o equipamento foi ensaiado em uma solução saturada a 5% de NaCl p/p, à 35 °C, pelo tempo de 200 h e foi aprovado para uso em atmosferas salinas, condicionado à utilização de acessórios de instalação no mesmo material do equipamento e de bujões de aço inoxidável ASTM-A240, para fechamento das entradas roscadas não utilizadas. Os materiais de fabricação dos equipamentos aprovados para letra "W" são: aço inoxidável AISI 316 e alumínio Copper Free SAE 336 pintados (Procedimento P-CQ-FAB764-10) com tinta Resina Poliéster ou Resina Epoxy com espessura da camada de tinta de 70 a 150 µm e 120 a 200 µm, respectivamente, ou pintados com o plano de pintura P1 e P2 (Procedimento P-CQ-FAB-765-05) com tinta Resina Epoxy ou Poliuretano Acrílico Alifático com espessura de camada de tinta de 290 µm a 405 µm e 185 µm a 258 µm, respectivamente.

Os planos de pintura P1 e P2 são permitidos apenas para equipamento fornecido com plaqueta de identificação com marcação para grupo de gás IIB.

O grau de proteção IP68 só é garantido se nas entradas roscadas de ½" NPT for utilizado vedante não endurecível à base de silicone conforme Procedimento P-DM-FAB277-07.

O segundo numeral oito indica que o equipamento foi ensaiado para uma condição de submersão de dez metros por vinte e quatro horas. O acessório deve ser instalado em equipamentos com grau de proteção equivalente.

É responsabilidade do fabricante assegurar que todos os transformadores da placa analógica tenham sido submetidos com sucesso aos ensaios de rotina de 1500 V durante um minuto.

Este certificado é válido apenas para os produtos dos modelos avaliados. Qualquer modificação nos projetos, bem como a utilização de componentes ou materiais diferentes daqueles definidos pela documentação descritiva dos produtos, sem a prévia autorização do Cepel, invalidará este certificado.

É responsabilidade do fabricante assegurar que os produtos fornecidos ao mercado nacional estejam de acordo com as especificações e documentação descritiva avaliada, relacionadas neste certificado.

As atividades de instalação, inspeção, manutenção, reparo, revisão e recuperação dos equipamentos são de responsabilidade dos usuários e devem ser executadas de acordo com os requisitos das normas técnicas vigentes e com as recomendações do fabricante.

A marcação é executada conforme a Norma ABNT NBR IEC 60079-0:2020 e o Requisito de Avaliação da Conformidade de Equipamentos Elétricos para Atmosferas Explosivas nas Condições de Gases e Vapores Inflamáveis (RAC), e é fixada na superfície externa do equipamento, em local visível. Esta marcação é legível e durável, levando-se em conta possível corrosão química.

Normas Aplicáveis:

ABNT NBR IEC 60079-0:2013 Atmosferas explosivas - Parte 0: Equipamentos – Requisitos gerais

ABNT NBR IEC 60079-1:2016 Atmosferas explosivas - Parte 1: Proteção de equipamento por invólucro à prova de explosão "d"

ABNT NBR IEC 60079-11:2013 Atmosferas explosivas - Parte 11: Proteção de equipamento por segurança intrínseca "i"

ABNT NBR IEC 60079-26:2016 Equipamentos elétricos para atmosferas explosivas - Parte 26: Equipamentos com nível de proteção de equipamento (EPL) Ga

ABNT NBR IEC 60079-31:2014 Atmosferas explosivas - Parte 31: Proteção de equipamentos contra ignição de poeira por invólucros "t"

ABNT NBR IEC 60529:2017 Graus de proteção para invólucros de equipamentos elétricos (Código IP)

Desenhos 102A1376, 102A1256, 102A2036, 102A2035, 102A2090

Identification Plates

FM Approvals

smar LD303 Pressure Transmitter
BR - 14160
Made in Brazil

Temp.Class:T4	XP CL I, DIV 1, GP A,B,C,D.
Tamb. 60°C max.	DIP CL II,III, DIV 1, GP E,F,G.
Vmax. 24 VDC	S CL III, DIV 1.
I max. 250 mA	IS CL I,II,III, DIV 1, GP A,B,C,D,E,F,G.
Ci 5 nF	NI CL I, DIV 2, GP A,B,C,D.
Li 8 uH	Per inst. dwg 102A0078. Pmax= 5800 psi.

FM APPROVED Type 4X/6/6P

0044333 - 2007 PROFIBUS-PA  122000

smar LD303 Pressure Transmitter
BR - 14160
Made in Brazil

Temp.Class:T4	XP CL I, DIV 1, GP A,B,C,D.
Tamb. 60°C max.	DIP CL II,III, DIV 1, GP E,F,G.
Vmax. 24 VDC	S CL III, DIV 1.
I max. 250 mA	IS CL I,II,III, DIV 1, GP A,B,C,D,E,F,G.
Ci 5 nF	NI CL I, DIV 2, GP A,B,C,D.
Li 8 uH	Per inst. dwg 102A0078. Pmax= 5800 psi.

FM APPROVED Type 4X/6/6P

0044333 - 2007 PROFIBUS-PA  134300

smar LD303 Pressure Transmitter
TX - 77040
Made in USA

Temp.Class:T4	XP CL I, DIV 1, GP A,B,C,D.
Tamb. 60°C max.	DIP CL II,III, DIV 1, GP E,F,G.
Vmax. 24 VDC	S CL III, DIV 1.
I max. 250 mA	IS CL I,II,III, DIV 1, GP A,B,C,D,E,F,G.
Ci 5 nF	NI CL I, DIV 2, GP A,B,C,D.
Li 8 uH	Per inst. dwg 102A0078. Pmax= 5800 psi.

FM APPROVED Type 4/6/6P

0000000 - 0000 PROFIBUS-PA  164201

smar LD303 Pressure Transmitter
TX - 77040
Made in USA

Temp.Class:T4	XP CL I, DIV 1, GP A,B,C,D.
Tamb. 60°C max.	DIP CL II,III, DIV 1, GP E,F,G.
Vmax. 24 VDC	S CL III, DIV 1.
I max. 250 mA	IS CL I,II,III, DIV 1, GP A,B,C,D,E,F,G.
Ci 5 nF	NI CL I, DIV 2, GP A,B,C,D.
Li 8 uH	Per inst. dwg 102A0078. Pmax= 5800 psi.

FM APPROVED Type 4X/6/6P

0000000 - 0000 PROFIBUS-PA  164301

DNV GL Presafe A/S / EXAM (BBG Prüf - und Zertifizier GmbH)

smar LD303 Pressure Transmitter
Nova Smar S/A
Av. Dr Antônio Furlan Jr
1028 Sertãozinho-SP
14170-480
Brazil

Ex II 1/2G Ex ia IIC T4/T5/T6 Ga/Gb DMT 00 ATEX E 067 ()
Pi = 5,32 W -40°C ≤ Ta ≤ +60°C
Ui = 24 VDC li = 380 mA Li = neg Ci ≤ 5 nF

IP66
IP68 10m/24h

0000000 - 0000 PROFIBUS-PA  0470 146704

smar LD303 Pressure Transmitter
Nova Smar S/A
Av. Dr Antônio Furlan Jr
1028 Sertãozinho-SP
14170-480
Brazil

Ex II 1/2G Ex ia IIC T4/T5/T6 Ga/Gb DMT 00 ATEX E 067 ()
Pi = 5,32 W -40°C ≤ Ta ≤ +60°C
Ui = 24 VDC li = 380 mA Li = neg Ci ≤ 5 nF

IP66W
IP68W 10m/24h

0000000 - 0000 PROFIBUS-PA  0470 152304

smar LD303 Pressure Transmitter
Nova Smar S/A
Av. Dr Antônio Furlan Jr
1028 Sertãozinho-SP
14170-480
Brazil

Ex db IIC T6 Gb IECEx PRE 18.0031X ()
Tamb = -20°C to 60°C
U = 28 VDC

IP66
IP68 10m/24h

0000000 - 0000 PROFIBUS-PA 211501

smar LD303 Pressure Transmitter
Nova Smar S/A
Av. Dr Antônio Furlan Jr
1028 Sertãozinho-SP
14170-480
Brazil

Ex db IIC T6 Gb IECEx PRE 18.0031X ()
Tamb = -20°C to 60°C
U = 28 VDC

IP66W
IP68W 10m/24h

0000000 - 0000 PROFIBUS-PA 211601

smar LD303 Pressure Transmitter
BR - 14160
Sertãozinho
Brazil

Ex I M1 Ex ia I Ma DMT 00 ATEX E 067
-40°C ≤ Ta ≤ +60°C
Pi = 5,32 W
Ui = 24 VDC li = 380 mA Li = neg Ci ≤ 5 nF

IP 66 68

0000000 - 0000 PROFIBUS-PA  0470 146901

smar LD303 Pressure Transmitter
BR - 14160
Sertãozinho
Brazil

Ex I M1 Ex ia I Ma DMT 00 ATEX E 067
-40°C ≤ Ta ≤ +60°C
Pi = 5,32 W
Ui = 24 VDC li = 380 mA Li = neg Ci ≤ 5 nF

IP 66 W 68 W

0000000 - 0000 PROFIBUS-PA  0470 152501



CEPEL (Centro de Pesquisa de Energia Elétrica)

smar LD303 Transmissor de Pressão
 Nova Smar S/A
 Av. Dr. Antônio Furlan Jr
 1028 Sertãozinho-SP
 14170-480
 Brazil

FISCO Field Device - Ex ia IIC T4 Ga
 FISCO Field Device - Ex ic IIC T4 Gc

Ex db IIC T6 Ga/Gb CEPEL 98.0054 ()
 Ex ia IIC T4/T5 Ga/Gb CEPEL 96.0075 X ()

Tamb= -20° a 65°C (T4) -20° a 50°C (T5)
 Ui= 30V li= 380mA Pi= 5,32W
 Ci= 5nF Li= desp

Segurança



IP 66 68



0000000 - 0000 PROFIBUS-PA  137603

smar LD303 Transmissor de Pressão
 Nova Smar S/A
 Av. Dr. Antônio Furlan Jr
 1028 Sertãozinho-SP
 14170-480
 Brazil

FISCO Field Device - Ex ia IIC T4 Ga
 FISCO Field Device - Ex ic IIC T4 Gc

Ex db IIC T6 Ga/Gb CEPEL 98.0054 ()
 Ex ia IIC T4/T5 Ga/Gb CEPEL 96.0075 X ()

Tamb= -20° a 65°C (T4) -20° a 50°C (T5)
 Ui= 30V li= 380mA Pi= 5,32W
 Ci= 5nF Li= desp

Segurança



IP 66W 68W



0000000 - 0000 PROFIBUS-PA  125603

smar LD303 Transmissor de Pressão
 Nova Smar S/A
 Av. Dr. Antônio Furlan Jr
 1028 Sertãozinho-SP
 14170-480
 Brazil

FISCO Field Device - Ex ia IIC T4 Ga
 FISCO Field Device - Ex ic IIC T4 Gc

Ex db IIB T6 Ga/Gb CEPEL 98.0054 ()
 Ex ia IIB T4/T5 Ga/Gb CEPEL 96.0075 X ()

Tamb= -20° a 65°C (T4) -20° a 50°C (T5)
 Ui= 30V li= 380mA Pi= 5,32W
 Ci= 5nF Li= desp

Segurança



IP 66 68
 P1/P2 Pintura



0000000 - 0000 PROFIBUS-PA  203601

smar LD303 Transmissor de Pressão
 Nova Smar S/A
 Av. Dr. Antônio Furlan Jr
 1028 Sertãozinho-SP
 14170-480
 Brazil

FISCO Field Device - Ex ia IIC T4 Ga
 FISCO Field Device - Ex ic IIC T4 Gc

Ex db IIB T6 Ga/Gb CEPEL 98.0054 ()
 Ex ia IIB T4/T5 Ga/Gb CEPEL 96.0075 X ()

Tamb= -20° a 65°C (T4) -20° a 50°C (T5)
 Ui= 30V li= 380mA Pi= 5,32W
 Ci= 5nF Li= desp

Segurança





IP 66W 68W
 P1/P2 Pintura

0000000 - 0000 PROFIBUS-PA  203501

smar LD303 Transmissor de Pressão
 Nova Smar S/A
 Av. Dr. Antônio Furlan Jr
 1028 Sertãozinho-SP
 14170-480
 Brazil

Ex tb IIIC T85°C Db CEPEL 98.0054 ()
 Ex ia IIIC T135°C/T100°C Da CEPEL 97.0075 X ()

Tamb= -20° a 65°C (T135°C)
 -20° a 50°C (T100°C)
 Ui= 30V li= 380mA Pi= 5,32W
 Ci= 5nF Li= desp

Segurança



IP 66 68

0000000 - 0000 PROFIBUS-PA  209001

FM Approvals

NON HAZARDOUS OR DIVISION 2 AREA

SAFE AREA APPARATUS

UNSPECIFIED, EXCEPT THAT IT MUST NOT BE SUPPLIED FROM, NOR CONTAIN UNDER NORMAL OR ABNORMAL CONDITIONS, A SOURCE OF POTENTIAL IN RELATION TO EARTH IN EXCESS OF 250VAC OR 250VDC.

ASSOCIATED APPARATUS

OPTIONAL SHIELDING

FIELDBUS BARRIER

GROUND BUS

POWER SUPPLY

HAZARDOUS AREA

REQUIREMENTS:

- 1 - INSTALLATION MUST BE IN ACCORDANCE WITH THE NATIONAL ELECTRICAL CODE (ANSI/NFPA 70) AND ANSI/ISA-RP12.6
- 2 - TRANSMITTER SPECIFICATION MUST BE IN ACCORDANCE TO APPROVAL LISTING.
- 3 - ASSOCIATED APPARATUS GROUND BUS TO BE INSULATED FROM PANELS AND MOUNTING ENCLOSURES.
- 4 - WIRES: TWISTED PAIR, 22AWG OR LARGER.
- 5 - SHIELD IS OPTIONAL IF USED, BE SURE TO INSULATE THE END NOT GROUNDED.
- 6 - CABLE CAPACITANCE AND INDUCTANCE PLUS C_i AND L_i MUST BE SMALLER THAN C_g AND L_g OF THE ASSOCIATED APPARATUS.

INTRINSICALLY SAFE APPARATUS

ENTITY VALUES: C_i = 5nF L_i = 8uH
V_{max} ≤ 24V
I_{max} ≤ 250mA

COMPONENTS CAN NOT BE SUBSTITUTED WITHOUT PREVIOUS MANUFACTURER APPROVAL.

CLASS I,II,III DIV.1, GROUPS A,B,C,D,E,F & G
MODELS LD292, LD293, LD302 AND LD303 - SERIES
ABSOLUTE, GAGE AND DIFFERENTIAL
PRESSURE AND LEVEL TRANSMITTERS
MAXIMUM WORKING PRESSURE RATING: 40MPa (5800 psi). SEE MANUAL.

APPROVAL CONTROLLED BY C.A.R.

8	MARCIAL 20/10/08	MISSAWA 20/10/08	ALT-DE- 0049/08	DRAWING	DESIGN	VERIFIED	APPROVED
7	MELONI 16/07/07	MISSAWA 16/07/07	ALT-DE- 0004/07	MELONI 23/03/95	M.MISSAWA 23/03/95	SINASTRE 23/03/95	PELUSO 23/03/95
6	J.RODRIGO 19/09/05	MISSAWA 19/09/05	ALT-DE- 0076/05	CUSTOMER:			
5	MOACIR 05/05/03	CASSIOLATO 05/05/03	ALT DE 0043/03	EQUIPMENT: LD292/293/302/303			
REV.	DESIGN	APPROVED	AREA	CONTROL DRAWING			

APPROVED

smar	
DRAWING N. 102A0078	REV 08
:	SH. 01/01

Appendix B

		SRF – Service Request Form Pressure Transmitters		Proposal No.: (1)	
Company:			Unit:		Invoice:
COMMERCIAL CONTACT			CUSTOMER CONTACT		
Full Name:			Full Name:		
Function:			Function:		
Phone:		Extension:		Phone:	
Fax:		Extension:		Fax:	
Email:			Email:		
EQUIPMENT DATA					
Model:		Serial Number:		Sensor Number:	
Technology: () 4-20 mA () HART [®] () HART [®] SIS () WIRELESS HART [®] () ISP () FOUNDATION fieldbus [™] () PROFIBUS PA					Firmware Version:
PROCESS DATA					
Process Fluid:					
Calibration Range (4)		Ambient Temperature (°F)		Process Temperature (°F)	
Min.:	Max.:	Min.:	Max.:	Min.:	Max.:
Process Pressure (4)		Static Pressure (4)		Vacuum (4)	
Min.:	Max.:	Min.:	Max.:	Min.:	Max.:
				() Transmitter () Repeater	
Normal Operation Time:				Failure Date:	
FAILURE DESCRIPTION (Please, describe the observed behavior, if it is repetitive, how it reproduces, etc.)					
Did device detect the fail? (2) () Yes () No		What is the final value of the current? (2) _____ mA		What is the message in the display? (2)	
MAINTENANCE INFORMATION					
Did you allow the upgrade in the firmware? () Yes () No			Certification plate: Will it maintained the certification? () Yes () No		
Main board configuration: () Original factory configuration () Default configuration () Special configuration (should be informed by the client. Please, use the space below)					
OBSERVATIONS					
SUBMITTER INFORMATION					
Company:					
Submitted by:		Title:		Section:	
Phone:		Extension:		E-mail:	
Date:		Signature:			
For warranty or non-warranty repair, please contact your representative. Further information about address and contacts can be found on www.smar.com/contactus.asp .					
NOTE					
(1) This field should be filled out by the Smar.		(3) Required for Wireless HART [®] devices.			
(2) Required for SIS devices.		(4) Required to specify the pressure unit.			

