

Operating Manual Linear Actusafe CM FS



Inhaltsverzeichnis

Inhaltsverzeichnis	2
Manual for Linear Failsafe-Actuators - CM FS	5
1 Safety instructions	5
2 Introduction	6
3 Functional Description of the CM FS Failsafe Drive	7
3.1 Failsafe-direction	8
3.2 Moving-behaviour of the actuator	8
3.2.1 Moving behaviour electrical mode	8
3.2.2 Moving behaviour failsafe mode	8
4 General Information	8
4.1 Serial number	8
4.2 Protection class	8
4.3 Mounting position	8
4.4 Direction of rotation	8
4.5 Protective devices	9
4.6 Ambient temperature	9
4.7 Condition on delivery of the actuators	9
4.8 Note (tag)	9
5 Transport and Storage	9
6 Installation Instructions	9
6.1 Mechanical connection; preparations	9
6.2 Mounting of Linear Failsafe actuator	10
6.2.1 Mounting procedure for valve without required sealing force	10
6.2.2 Alternative procedure for valve with required sealing force	12
6.3 Mounting position of the control unit	12
6.4 Electrical connection	12
7 Commissioning	12
7.1 General information	12
7.2 Manual operation	12
7.2.1 Activate manual operation	13
7.2.2 Deactivate manual operation	13
7.2.3 Direction of rotation handwheel for closing the valve, Failsafe „move out“	14
7.2.4 Direction of rotation handwheel for closing the valve, Failsafe „move in“	15
7.3 Mechanical default setting, preparation	15
7.4 Setting the end positions	15
7.5 Adjusting of Failsafe speed	16
7.6 Final work	17
8 The control unit	17
9 Maintenance	18
10 Technical data failsafe brake	19
10.1 CM03FS	19
10.2 CM06FS	19
11 Spare parts	19
12 Lubricant recommendation / Lubricant requirements	19
12.1 Basic lubricant service interval	19
13 Training	19

Operating Manual ACTUSMART CM.V1.2	20
1 Introduction/Notes	20
2 General	20
2.1 Overview	20
2.2 Serial number and type label	21
2.3 Operating mode	21
2.4 Protection class	21
2.5 Mounting position	22
2.6 Direction of rotation	22
2.7 Protection devices	22
2.7.1 Torque	22
2.7.2 Motor temperature	22
2.7.3 Input fuse, thermal fuse	23
2.8 Ambient temperature	23
2.9 Delivery condition of the actuators	23
2.10 Information notice (tag)	23
3 Packaging, transport and storage	24
3.1 General	24
3.2 Storage	24
3.3 Long-term storage	24
4 Installation instructions	25
4.1 Mechanical connection	25
4.2 Mounting position of the operating unit	26
4.3 Electrical connection	27
4.3.1 Power supply connection	27
5 Commissioning	29
5.1 General	29
5.2 Manual operation	29
5.3 Mechanical default settings, preparation	29
5.4 End limit setting	29
5.4.1 End limit OPEN	29
5.4.2 End limit CLOSE	33
5.5 Final works	33
6 Control Unit	33
6.1 Operating unit	33
6.2 Display elements	34
6.2.1 Graphic display	34
6.2.2 LED Display	34
6.3 Operation	35
6.3.1 Operation mode	36
6.3.2 Configuration	37
6.3.3 Configuration example	37
6.3.4 „TEACHIN“	39
7 Parameter menu	40
7.1 Parameter group: End limit	40
7.2 Parameter group: Torque	42
7.3 Parameter group: Speed	43
7.4 Parameter group: Ramp (optional)	43
7.5 Parameter group: Control	43
7.6 Parameter group: Password	43
7.7 Parameter group: Position	44
7.8 Parameter group: Binary inputs	44
7.9 Parameter group: Binary outputs	47
7.10 Parameter group: Position output (optional)	50
7.11 Parameter group: Step mode	51
7.12 Parameter group: Positioner (optional)	52

7.13	Parameter group: PID controller (optional)	55
7.14	Parameter group: Bus systems (optional)	56
7.15	Parameter group: Characteristic curves (optional)	56
7.15.1	Torque characteristic	56
7.15.2	Speed characteristic	57
7.15.3	Valve characteristic	58
7.16	Parameter group: Identification (optional)	59
7.17	Parameter group: System parameters (locked)	59
7.18	Parameter group: Miscellaneous	60
8	Status area	61
8.1	Status	61
8.1.1	Status – binary outputs	61
8.1.2	Status – binary inputs	61
8.1.3	Status – analog values	61
8.1.4	Status – absolute values	62
8.1.5	Status – firmware	62
8.1.6	Status – serial number	63
8.1.7	Status – meter readings	63
8.2	History	63
9	Infrared connection	63
10	Bluetooth connection	64
11	Maintenance	64
12	Troubleshooting	65
12.1	Error list	66
13	Fuses	68
14	Spare parts	68
15	Lubricant recommendation, lubricant requirements	68
15.1	Main body: -25 to +60°C	69
15.2	Main body: -40 to +60°C	69
15.3	Output type A and spindle drives (linear actuators) -40 to +60°C	69
15.4	Basic lubricant service interval	69
16	Training	70
17	Original Declaration of Incorporation of Partly Completed Machinery	71
18	Declaration of Conformity	72
19	Declaration of Conformity	73
20	Technical data	74
20.1	Binary outputs	74
20.2	Binary inputs	74
20.3	Analog inputs	76
20.4	Analog output	77
20.5	Auxiliary voltage input and output	77
20.6	Connections	78
20.6.1	Connections for non explosion-proof version	78
20.6.2	Connections for explosion-proof version	78
20.7	Miscellaneous	78
21	Technical data CM03	78
21.1	Standard version CM03	79
21.2	24 VDC version CM03	79
21.3	400 V version CM03	79
22	Technical data CM06	79
22.1	Standard version CM06	79
22.2	400V version CM06	80

Manual for Linear Failsafe-Actuators - CM FS

1 Safety instructions

WARNING

When operating electrical devices, certain parts are inevitably under dangerous voltage. Work on the electrical systems or components may only be carried out by electricians or by individuals who have been instructed how to do so, working under the guidance and supervision of an electrician in accordance with electro technical regulations.



When working in potentially explosive areas, heed European Standards EN 60079-14 "Installing Electrical Systems in Explosion Endangered Areas" and EN 60079-17 "Inspection and Maintenance of Electrical Installations in Explosion Endangered Areas".



Working in potentially explosive areas is subject to special regulations (European Standard EN 60079-17), which must be complied with. Any additional national regulations must be heeded.

Working on the opened and energized actuator may only be carried out if it is ensured that there is no risk of explosion for the duration of the work.



2 Introduction

NOTICE: Also heed the Operating Manual for ACTUSMART CM



Linear Actusafe actuators are designed to operate appropriate valves when a fail-safe functionality is required.

Appropriate valves are all kind of valves that require a lineare movement to operate(valves, gate valves, etc.).

In the event of a power failure or if the fail-safe function is triggered deliberately, the linear Actusafe actuator shifts the valve to the fail-safe position, using the built-in energy storage device to do so.



Bild 1

3 Functional Description of the CM FS Failsafe Drive

In normal operation, the actuator is operated by the motor (1). Via a worm gear stage (2) and a planetary gear train (3), the motor drives the spindle nut of a ball screw (4). The sun gear shaft of the planetary gear train is fixed in place by an operating current brake (5).

The ball screw converts the rotational movement of the gear unit into linear motion, which, on the one hand, tension the spring (6), which acts as an energy storage device. On the other hand, the linear motion is transmitted to the valve stem (8) via a spring-loaded spindle pin (7).

There are no engaging or disengaging elements between the motor, the energy storage device and the fitting shaft in the actuator. All the gear unit components are permanently engaged.

While moving against the fail-safe direction, the electric motor has to move both the valve and the energy storage device (spring) for the fail-safe stroke.

If the supply for the operating current brake is interrupted (by a power failure, or intentionally to trigger a fail-safe stroke, the actuator will no longer be held, and the energy stored in the spring will be converted into kinetic energy. The actuator starts, forced by the spring, to move the valve in the failsafe position. In this case, the entire gear chain of the actuator with the exception of the worm gear stage will be moved until the end stop of the valve is reached. The spring-loaded spindle pin (7) dampens the stop to protect the valves seat.

Owing to this operating principle, neither an initialising stroke nor resetting of the actuator is required after a failsafe stroke. As soon as the power supply is restored, the actuator is ready for operation.



Bild 2: 1... Motor, 2... Worm gear stage, 3... Planetary gear train, 4... Ball screw, 5... Electrical holding brake, 6... Spring, 7... spring-loaded spindle pin, 8... valve stem

3.1 Failsafe-direction

This type of failsafe actuator can be built in a version for „Failsafe: stem move out“ or „Failsafe: stem move in“. A subsequent change of failsafe-direction is not possible!

3.2 Moving-behaviour of the actuator

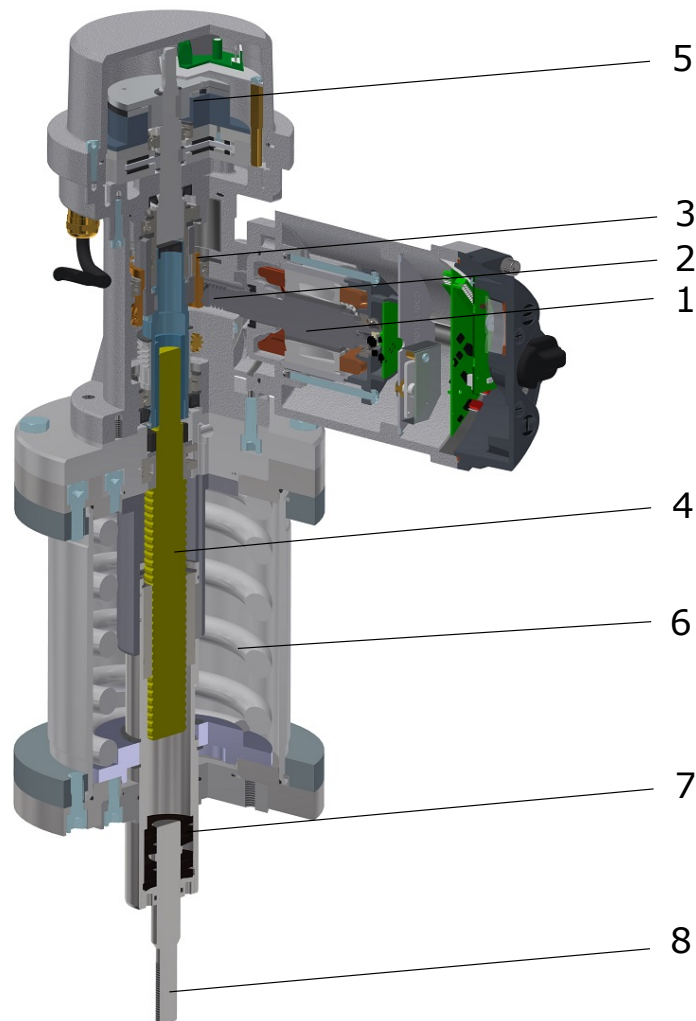
How the actuator moves to the end limits depends on whether the actuator is in failsafe mode or in electrical mode.

3.2.1 Moving behaviour electrical mode

- **Moving in failsafe direction**

In this case the actuator moves in failsafe direction electrically by motor till the adjusted electrical end position. If the end limit is set travel dependent the actuator stops at this point. If the end limit is set force dependent the actuator moves electrically till the end position. In the end position the electrical holding brake is released and the actuator build up the force by the tensioned spring. **Attention: For force dependent end limit the end position should be set in a sufficient range before the mechanical end position to avoid damage on the valve.**

- **Moving against failsafe direction**

The actuator moves to the end position electrically by motor. If the end limit is set force dependent the force is build up by the motor. **Attention: For force dependent end limit the end position should be set in a sufficient range before the real end position to avoid damage on the valve.**

3.2.2 Moving behaviour failsafe mode

- **Moving in failsafe direction**

In failsafe mode the actuator can only move in failsafe direction. When the electrical holding brake is released the actuator moves against the end limit by spring. In this case the end limit is generally force dependent. The force in end position is build up by the residual spring force. If the end limit should be travel dependent this is only possible by changing the mechanical connection to the valve so the actuator reaches the internal end stop before the end stop of the valve.

The mechanical end stops in the actuator are not designed to move against them by torque regularly!



4 General Information

4.1 Serial number

See Operating Manual ACTUSMART CM.V1.2, section 2.2, page 21

4.2 Protection class

See Operating Manual ACTUSMART CM.V1.2, section 2.4, page 21

4.3 Mounting position

See Operating Manual ACTUSMART CM.V1.2, section 2.5, page 22

4.4 Direction of rotation

The standard direction of rotation for the actuator is:

- Clockwise = actuator stem to be retracted (move in)
- counter-clockwise = actuator stem to be extended (move out)

All the information in this Operating Manual refers to the standard direction of rotation.



4.5 Protective devices

See Operating Manual ACTUSMART CM.V1.2, section 2.7, page 22

4.6 Ambient temperature

See Operating Manual ACTUSMART CM.V1.2, section 2.8, page 23

4.7 Condition on delivery of the actuators

See Operating Manual ACTUSMART CM.V1.2, section 2.9, page 23

4.8 Note (tag)

See Operating Manual ACTUSMART CM.V1.2, section 2.10, page 23

5 Transport and Storage

See Operating Manual ACTUSMART CM.V1.2, section 3, page 24

6 Installation Instructions

Installation work of any kind for the actuator may only be performed by qualified personnel.

6.1 Mechanical connection; preparations:

Check:

- whether valve flange and actuator base match
- if the bore of the coupling piece coincides with the spindle pin and sufficient thread engagement is available

Make sure that both the valve and the actuator are in the failsafe position.

General procedure:

- Clean the bare parts on the actuator coated with rust protectant.
- Clean the mounting surface for the fitting thoroughly.
- Lightly grease the valve stem.
- Put the actuator on the valve.
- Pay attention to the centered position and full support surface of the flanges.
- Fasten the actuator with suitable bolts:
 - Minimum strength grade: 8.8 or A2-70
 - Ensure sufficient thread engagement (min. 1xd)
 - Screws that are too long may go against the thread root, creating the risk of the actuator moving radially vis-à-vis the fitting. This may lead to the bolts shearing off.

NOTICE: Unsuitable bolts may result in the actuator falling off!

- Tighten bolts to the correct torque, alternating between bolts on opposite sides



Thread	Tightening torque [Nm] for bolts with strength grade	
	8.8	A2-70 / A4-70
M6	11	8
M8	25	18
M10	51	36
M12	87	61
M16	214	150
M20	431	294
M30	1489	564

6.2 Mounting of Linear Failsafe actuator

General:

Schiebel CM Failsafe actuators move the stem of valve to the failsafe position in case of failsafe event. In general stem of actuator is at failsafe position at delivery!

Depending on valve has to be closed or opened by force (sealing force is required in Failsafeposition) or by travel (actuator shall stop before touching the seat), mounting procedure has to be done different:

6.2.1 Mounting procedure for valve without required sealing force:

- Connect mounting kit to valve and fix according valve producer specification.
- Be sure stem of valve is exact in desired failsafe end position.
- Be sure stem of actuator is in failsafe position:
actuator must not be electrically connected!
handwheel must not be engaged
(if applicable, refer to section 7.2, page 12, Manual operation)!
- Mount actuator to mounting kit and fix with 4 screws.
- Check distance between end of stem of actuator and end of stem of valve:
allowed range of distance is 2 – 25mm.
- Connect both stems with coupling and note symmetrical engagement of both threads!
- Fix coupling with 4 screws and note both halves of coupling have to be parallel after tighten the screws.



Bild 3: Mounting Linear Failsafe with Linear Adapter

6.2.2 Alternative procedure for valve with required sealing force:

- Connect mounting kit to valve and fix according valve producer specification.
- Be sure stem of valve is exact in desired failsafe end position.
actuator must not be electrically connected!
handwheel must not be engaged
(if applicable, refer to section 7.2, page 12, Manual operation)!
- Mount actuator to mounting kit and fix with 4 screws.
- Check distance between end of stem of actuator and end of stem of valve:
allowed range of distance is 2 – 25mm.
- Move the Actuator electrically or by the handwheel 3-5mm out of the failsafe position.
- Connect both stems with coupling and note symmetrical engagement of both threads!
- Fix coupling with 4 screws and note both halves of coupling have to be parallel after tighten the screws.

6.3 Mounting position of the control unit

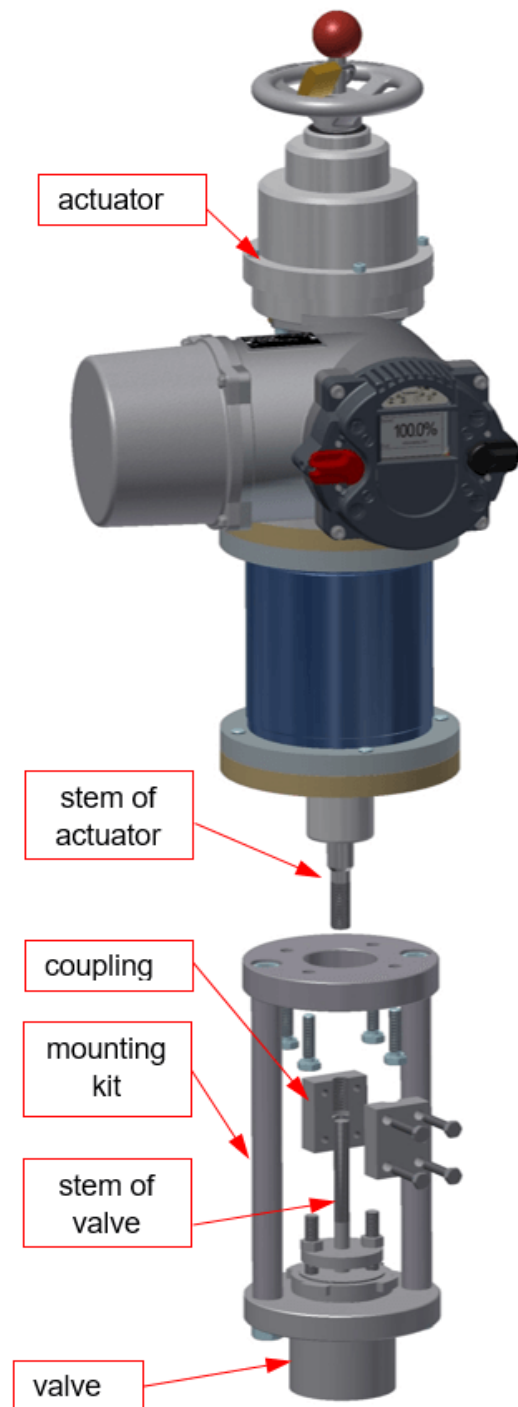
See Operating Manual ACTUSMART CM.V1.2, section 4.2, page 26

6.4 Electrical connection

See Operating Manual ACTUSMART CM.V1.2, section 4.3, page 27

7 Commissioning

It is assumed that the actuator has been installed and electrically connected correctly. (See section 4, page 25)

NOTICE: Remove silica gel from the alarm cover.

**7.1 General information**

NOTICE: When commissioning and each time after dismantling the actuator, the electrical end positions have to be reset (see chapter 5.4, Seite 29).

7.2 Manual operation

The manual operation is only possible if the actuator is delivered with the optional handwheel. This option allows an adjustment of the valve in de-energized state.

Caution:

- By activating the manual drive the failsafe function is disabled
- By activating the manual drive the electrical function of the drive is disabled. In normal operation, the hand wheel (9) has no effect, it rotates idly by.
- Note: The manual mode can be activated only when the drive is in the failsafe position.





Bild 4: 9... Handwheel, 10... coupling rod, 11... padlock

7.2.1 Activate manual operation

To activate manual mode:

- the padlock has to be removed
- the coupling rod has to be pushed all the way into the actuator.

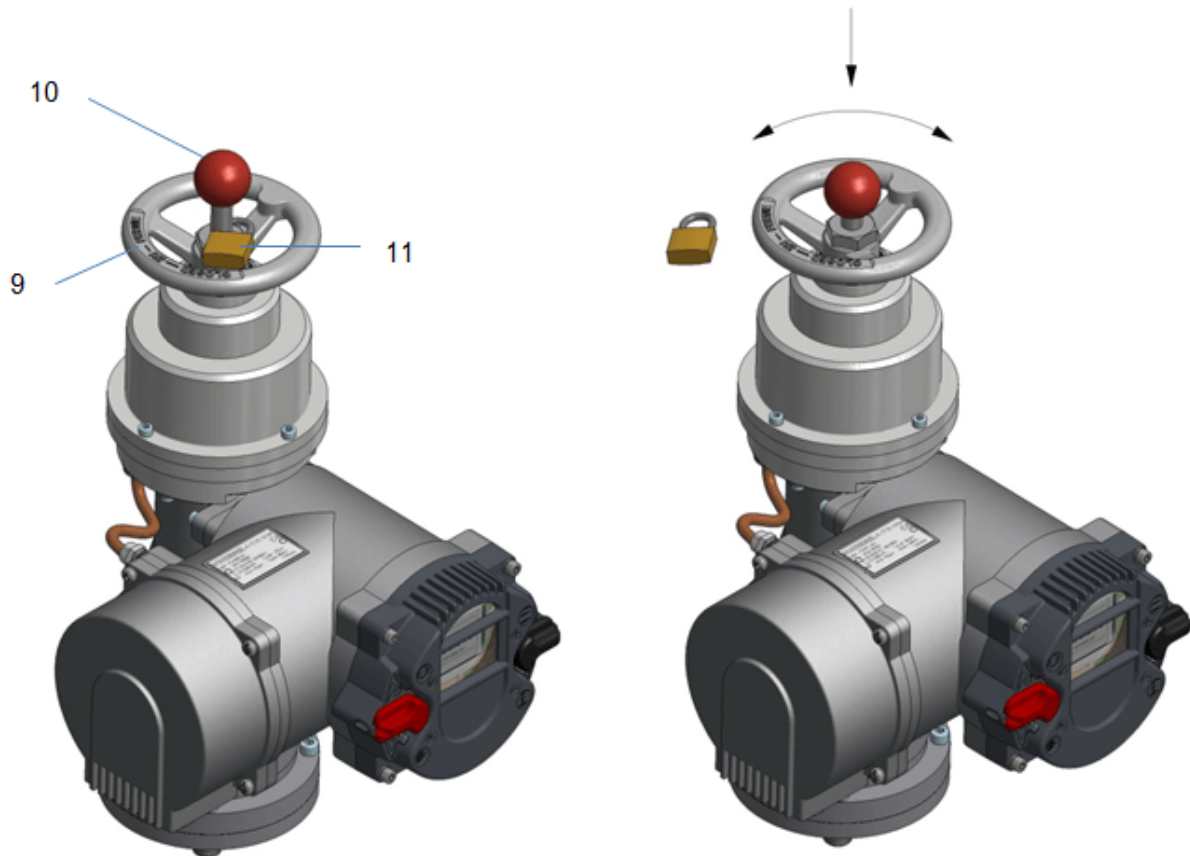
For easier clutch engagement move the hand wheel easily back and forth. Through the engagement the actuator is automatically electrically disabled and the display shows „manual operation“.

7.2.2 Deactivate manual operation

To exit the manual mode and enable the actuator again for the automatic mode must:

- the actuator be driven in the failsafe position by handwheel.
- the coupling rod be pulled up to the stop of the actuator.
- the coupling rod again secured with the padlock.

7.2.3 Direction of rotation handwheel for closing the valve, Failsafe „move out“



Bild 5: Rotation of direction for Failsafe direction „move out“.

7.2.4 Direction of rotation handwheel for closing the valve, Failsafe „move in“

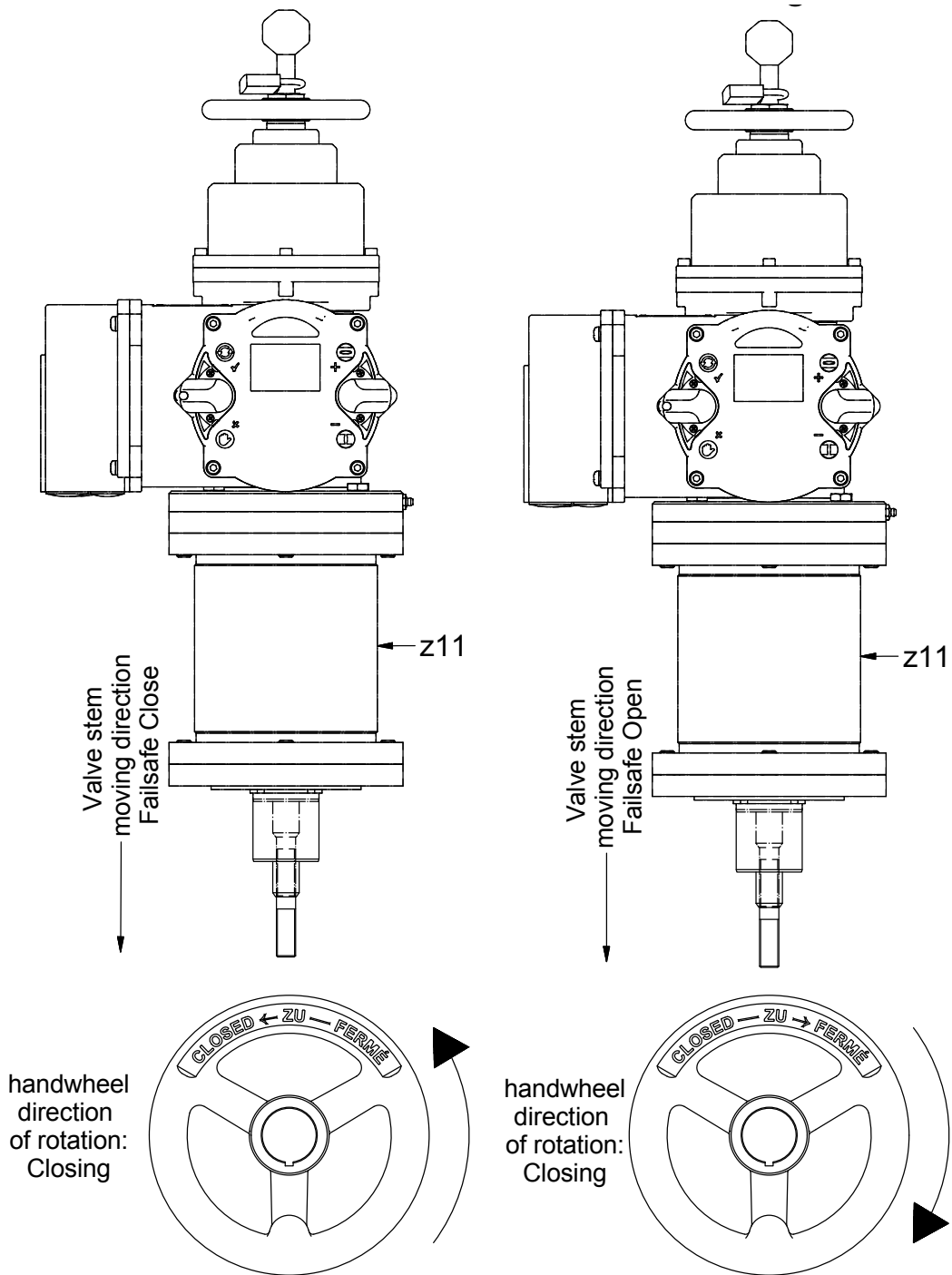

Bild 6: Rotation of direction for Failsafe direction „move in“.

7.3 Mechanical default setting, preparation

See Operating Manual ACTUSMART CM.V1.2, section 5.3, page 29

7.4 Setting the end positions

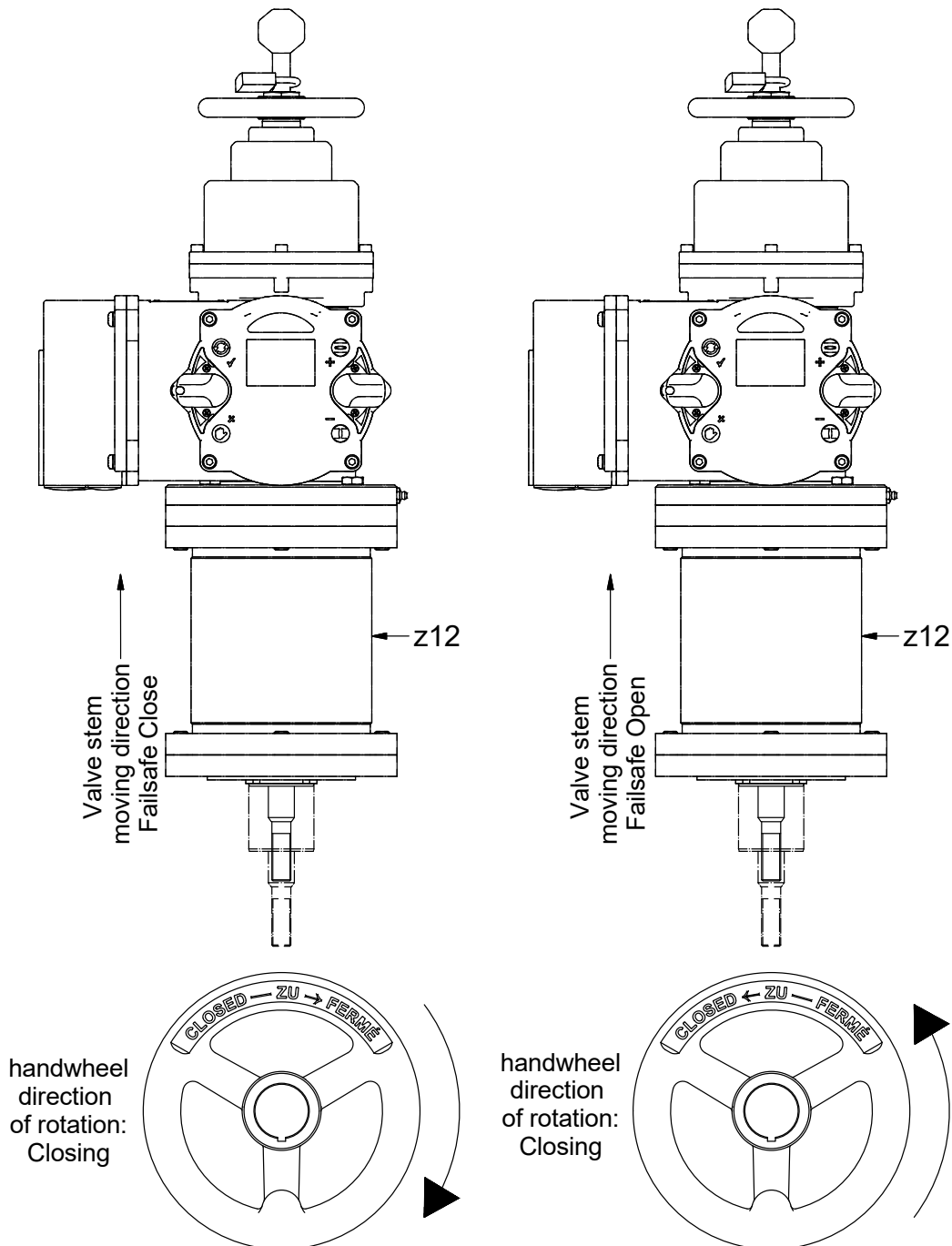
See Operating Manual ACTUSMART CM.V1.2, section 5.4, page 29

7.5 Adjusting of Failsafe speed

General:

Schiebel CM Failsafe actuators are equipped with an adjustable passive eddy current brake, by which it is possible to change the failsafe speed. When delivered the failsafe speed is set to minimum.

After mounting the actuator to valve and test run, failsafe speed can be increased if necessary.

NOTICE: Valve or piping may be damaged due to high actuating speed!

Setting procedure:

All adjustment work may only be performed with the actuator disconnected from the power supply. Due to this requirement, the actuator has to be in the fail-safe position! Any powering up must be ruled out during maintenance!

When working in potentially explosive areas, heed European Standards EN 60079-14 "Installing Electrical Systems in Explosion Endangered Areas" and EN 60079-17 "Inspection and Maintenance of Electrical Installations in Explosion Endangered Areas"



Bild 7: Cover removing

1. Remove cover according picture 7, page 16
NOTICE: In the version with handwheel there is a cable connection which has to be unplugged.
2. Loosen but do not remove 4pcs of screws according picture 8, page 17
3. Insert 3mm allen key into radial borehole of flange.
4. Turn flange by use of allen key in direction according picture 8, page 17
Half of possible rotating angle will approximately double failsafe speed of actuator.
While holding flange with key in desired position retighten screws.
5. In the version with handwheel reconnect the cable to the cover
6. Remount the cover while be aware of correct position of O-ring sealing
7. Retest actuator to check for correct failsafespeed

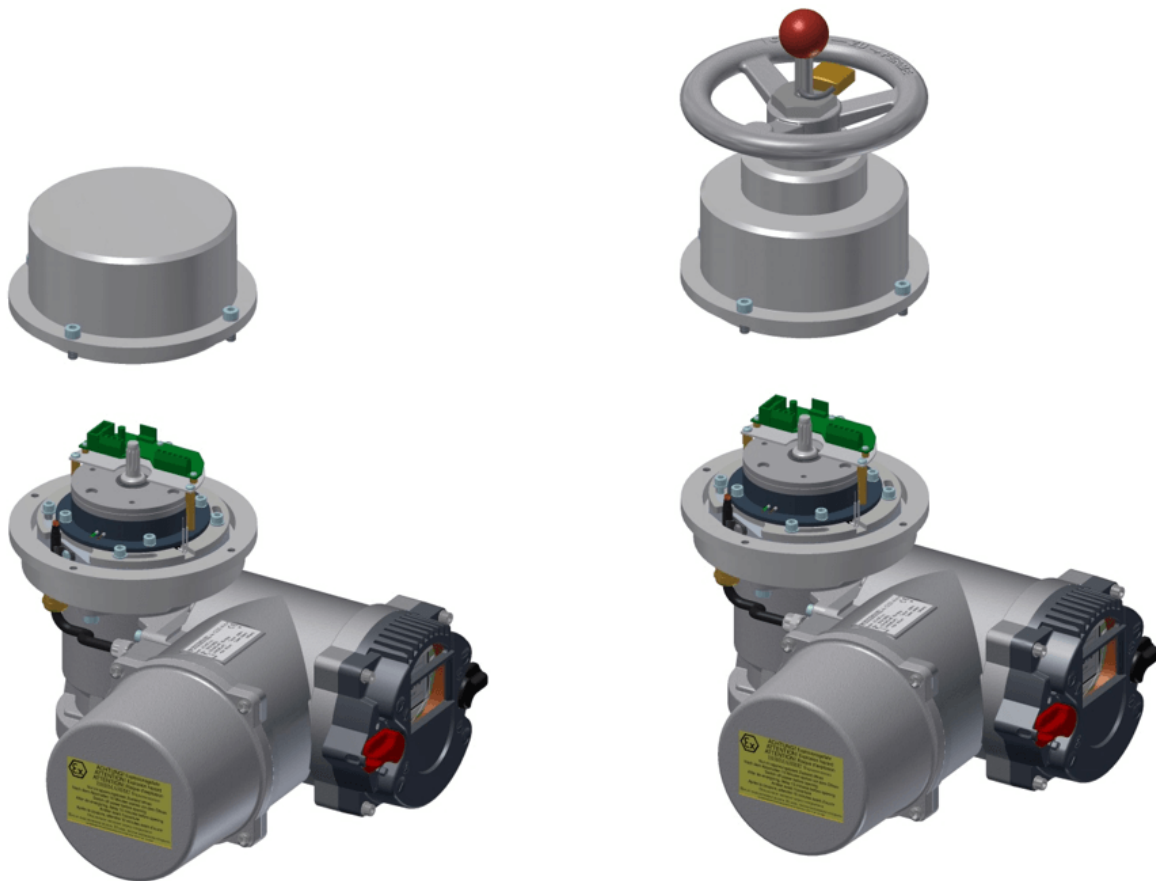

Bild 8: Adjusting speed

7.6 Final work

See Operating Manual ACTUSMART CM.V1.2, section 5.5, page 33

8 The control unit

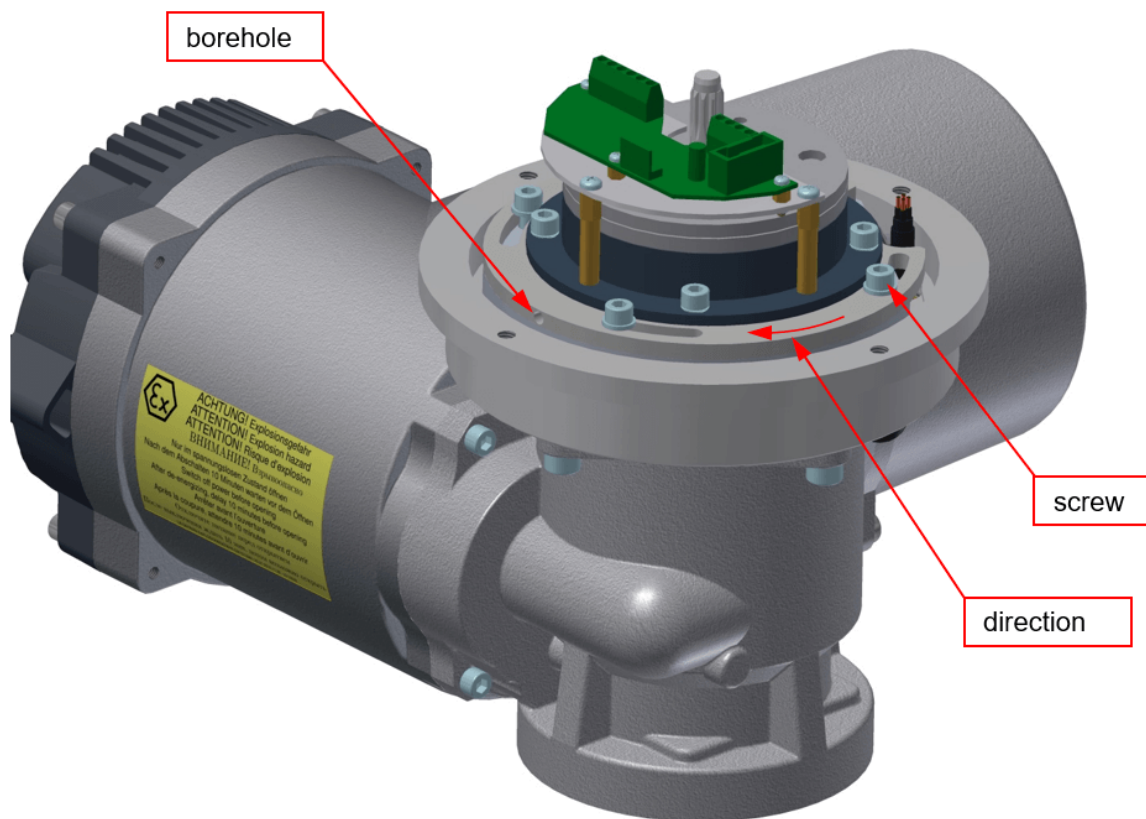
See Operating Manual ACTUSMART CM.V1.2, section 6, page 33

9 Maintenance

All maintenance work may only be performed with the actuator disconnected from the power supply.

Due to this requirement, the actuator has to be in the fail-safe position!

If this is not the case, it may be because of a fault in the fitting (stuck valve stem).



WARNING

The actuator has a pre-loaded coil spring or a disk spring assembly! When loosening the flange mounting bolts, the spring force against the valve can cause the actuator to come loose from the valve. Adequate safety measures must be taken



WARNING

Any powering up must be ruled out during maintenance! Work on the electrical systems or components may only be carried out by electricians or by individuals who have been instructed how to do so, working under the guidance and supervision of an electrician in accordance with electro technical regulations. After completing their commissioning, the actuators are ready for use. The actuator is filled with oil as standard when shipped.



Routine checks:

- Be mindful of increased running noises. In cases of long down times, operate the actuator at least every three months.
- Check the fail-safe function (check the operating time and smoothness of running in fail-safe operation). Lengthening in the running time may also be caused by an increased torque requirement for the fitting after long down times.

WARNING

The actuator has a pre-stressed coil spring or disk spring assembly. Improper dismantling may lead to both damage to the actuator as well as serious injuries! If maintenance work is needed requiring the actuator to be dismantled, contact SCHIEBEL Antriebstechnik GesmbH regarding detailed instructions and/or any special-purpose tools for relaxing the spring assembly!



The actuators are designed for any mounting position (See section 2.5, page 22), which is why there is neither a filling level indicator nor a drain plug on the main casing.

Depending on the stressing subjected to, do the following approx. every 10,000 to 20,000 hours (about 5 years; see section 15, page 68):

- Oil change
- Replace seals
- Check all the roller bearings and the worm gear assembly and replace if necessary.

Take the types of oils and greases to be used from our Lubricant Table. (See section 15, page 68)

Check the cable glands at regular intervals (annually) for tightness of the cables and retighten if necessary.



If the visual inspection (eg. dust or water penetration) indicates that the effectiveness of the Sealing elements of the cable entry has suffered damage or aging, such elements have to be replaced preferably by using the original spare parts from the manufacturer of the equipment or through cable entries of comparable quality as well as the same ex- or IP protection class.

10 Technical data failsafe brake

10.1 CM03FS

Torque:	15 Nm
Power:	16 W
Voltage:	24 V
Current:	0,67 A

10.2 CM06FS

Torque:	30 Nm
Power:	21 W
Voltage:	24 V
Current:	0,875 A

11 Spare parts

When ordering spare parts, let us know the serial number of the actuator.
A separate exploded diagram and a spare parts list is available for selecting spare parts.

12 Lubricant recommendation / Lubricant requirements

See Operating Manual ACTUSMART CM.V1.2, section 15, page 68

12.1 Basic lubricant service interval

See Operating Manual ACTUSMART CM.V1.2, section 15, page 68

13 Training

See Operating Manual ACTUSMART CM.V1.2, section 16, page 70

Operating Manual ACTUSMART CM.V1.2

1 Introduction/Notes

These operating instructions apply to SCHIEBEL actuators of the ACTUSMART CM series.

The scope of application covers the operation of industrial valves, e.g., globe valves, gate valves, butterfly valves and ball valves. For other applications please consult with the factory.

The manufacturer shall not be liable for incorrect use and possible damage arising thereof. The risk shall be borne solely by the user.

Using the unit as intended also entails the observance of these operating instructions!



When operating electrical equipment, certain parts inevitably carry hazardous voltage levels. Work on the electrical system or equipment must be carried out only in accordance with electrical regulations by a qualified electrician himself or by specially instructed personnel under the control and supervision of a qualified electrician.

Maintenance instructions must be observed as otherwise the safe operation of the actuator cannot be guaranteed.

Failure to follow the warning information may result in serious bodily injury or property damage. Qualified personnel must be thoroughly familiar with all warnings contained in this operating manual.

Proper transport, storage, installation, assembly and careful commissioning are essential to proper and safe operation.

When working in potentially explosive areas, observe the European Standards EN 60079-14 "Electrical Installations in Hazardous Areas" and EN 60079-17 "Inspection and Maintenance of Electrical Installations in Hazardous Areas".



Maintenance work on open actuators may only be conducted if these are de-energized. Reconnection during maintenance is strictly prohibited.



2 General

The actuator of the ACTUSMART CM series is a compact rotary actuator with integrated controller for valve operation. The integral multi-turn sensor allows setting the travel up to 105 revolutions without opening the housing.

2.1 Overview



Bild 9: 1... Handwheel, 2... Control unit (operating unit), 3... Connection compartment 4... Gear component

2.2 Serial number and type label

Each actuator of the ACTUSMART CM series carries a serial number. The serial number is a 10-digit number that begins with the year and that can be read from the type label (see Bild 10) of the actuator (the type label is located next to the handwheel – see Bild 11).

Using this serial number, SCHIEBEL can uniquely identify the actuator (type, size, design, options, technical data and test report).

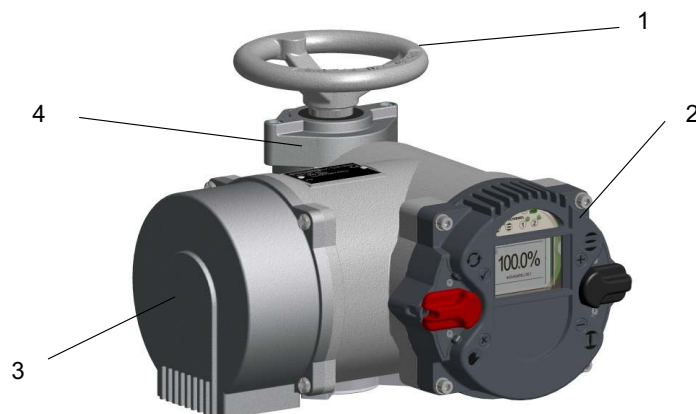

Bild 10: Type label



Bild 11: 1... Type label

Actuators which are suitable for operation in explosive atmosphere (see EU Directive 94/9/EG and EN 60079-0 Standard) are separately designated by a special type label (EEx, TÜV Standard, Bild 12).

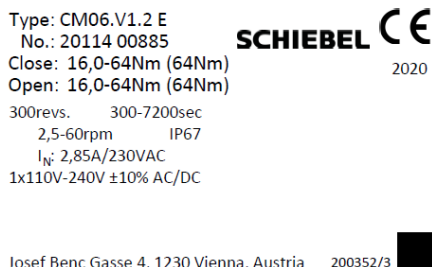

Bild 12: Type label of the actuator for operation in explosive atmosphere

2.3 Operating mode

ACTUSMART CM actuators are suitable for open-loop control (S2 operating mode – on/off duty) and closed-loop control (S4 operating mode – modulating duty) according to EN 60034-1.

2.4 Protection class

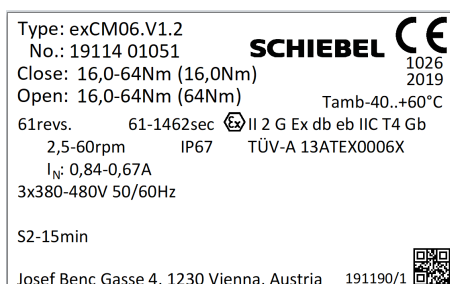
ACTUSMART CM actuators come by default with IP 67 (EN 50629) protection.

CAUTION: The protection class specified on the type label is only effective when the cable glands also provide the required protection class, the cover of the connection compartment is carefully screwed closed, and the mounting position (see section 2.5, page 22) is observed.



We recommend metallic screwed cable glands with a metrical thread. Furthermore, cable inlets that are not needed must be closed with screw plugs. On explosion-proof actuators, cable glands with protection class



EEx e acc. EN 60079-7 must be used. **After removing covers** for assembly purposes or adjustment work, take special care upon reassembly so that seals are not damaged and remain properly fastened. Improper assembly may lead to water ingress and to failures of the actuator.

The cover of the control unit – the operating unit (see Bild 9, page 20) – must not be opened!



Allow a certain sag in the connector cables before reaching the screwed cable glands so that water can drip off from the connector cables without running to the screwed cable glands. This way, forces acting on the screwed cable glands are also reduced (see section 2.5).

2.5 Mounting position

Generally, the installation position is irrelevant. However, based on practical experience, it is advisable to consider the following for outdoors use or in splash zones:

- Mount actuators with cable inlet facing downwards.
- Ensure that sufficient cable slack is available.

2.6 Direction of rotation

Unless specifically ordered otherwise, the standard direction is (see Bild 13 and Bild 14):

- **right turning (clockwise) = CLOSING**
- **left turning (counter-clockwise) = OPENING**

Clockwise rotation of the actuator is given when the output shaft turns counter clockwise when looking at the output shaft.



Bild 13: clockwise = close



Bild 14: counter-clockwise = close

CAUTION: All specifications in this operating manual refer to the standard direction of rotation.

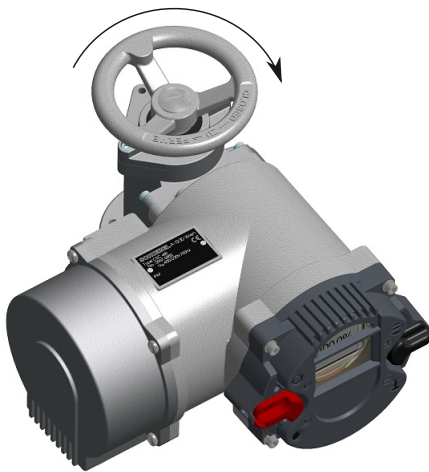

2.7 Protection devices

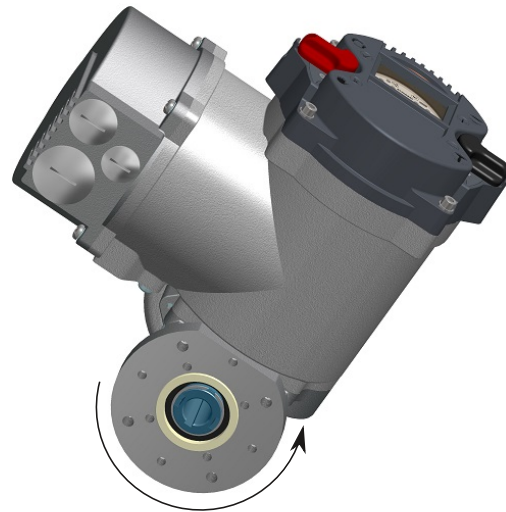
2.7.1 Torque

ACTUSMART actuators provide electronic torque monitoring.

The switch-off torque can be modified in the controller menu for each direction separately. By default, switch-off torque is set to the ordered value. If no torque was specified with the order, the actuator is supplied from the factory with the maximum configurable torque.

For more information, see section 7.2, page 42.

2.7.2 Motor temperature

All ACTUSMART CM actuators are normally equipped with motor winding temperature sensors, which protect the motor against excessive winding temperature.

The display will show the corresponding error upon exceeding the permissible motor temperature (see section 12.1, page 66).

2.7.3 Input fuse, thermal fuse

The frequency inverter is protected by an input fuse and the explosion-proof version also has a thermal fuse. If one of these fuses releases, a serious defect occurs and the frequency inverter will be disconnected permanent from the power supply. Then the frequency inverter must be changed.

2.8 Ambient temperature

Unless otherwise specified upon ordering, the following operating temperatures apply:

- On/off duty (open-loop control) -25 ... +60°C
- Modulating duty (closed-loop control) -25 ... +60°C
- explosion-proof version -20 ... +40°C (acc. EN 60079-0)
- explosion-proof version with extended temperature range -40 ... +60°C

CAUTION: The maximum operating temperature can also depend on further order-specific components. Please refer to the technical data sheets to confirm the as-delivered product specifications.



2.9 Delivery condition of the actuators

For each actuator, an inspection report is generated upon final inspection. In particular, this comprises a full visual inspection, calibration of the torque measurement in connection with an extensive run examination and a functional test of the micro controllers.

These inspections are conducted and documented according to the quality system and can be made available if necessary.

The basic setting of the end position must be performed after assembly on the actuator.

CAUTION: Commissioning instructions (see section 5, page 29) must be strictly observed!

During assembly of the supplied valves at the factory, end positions are set and documented by attaching a label (see Bild 15). During commissioning at the plant, these settings must be verified.



Bild 15: Label

2.10 Information notice (tag)

Each actuator is provided with a bilingual tag containing key information, which is attached to the handwheel after final inspection. This tag also shows the internal commission registration number (see Bild 16, page 24).



Bild 16: Tag

3 Packaging, transport and storage

Depending on the order, actuators may be delivered packed or unpacked. Special packaging requirements must be specified when ordering. Please use extreme care when removing or repackaging equipment

CAUTION: Use soft straps to hoist the equipment; do not attach straps to the handwheel. If the actuator is mounted on a valve, attach the hoist to the valve and not to the actuator.

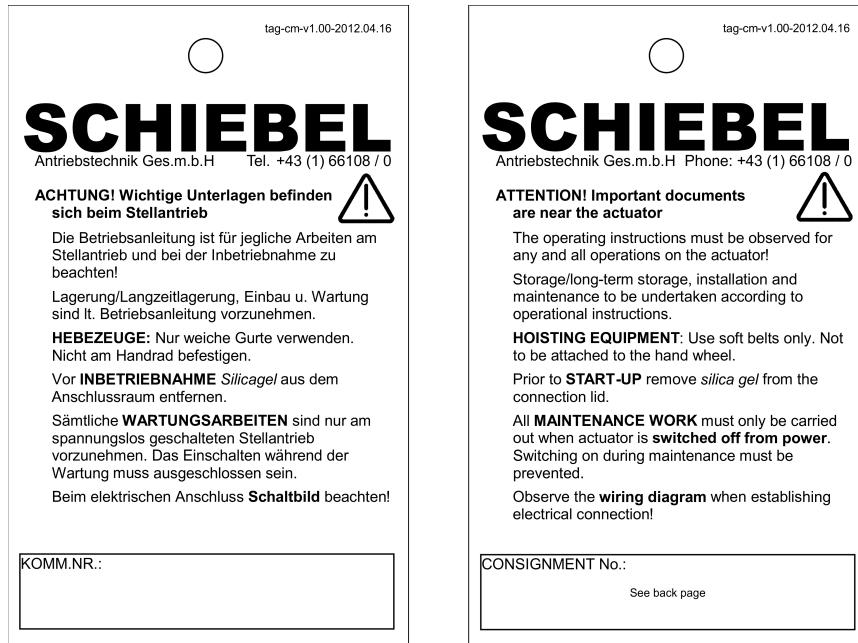

3.1 General

The connection compartment of ACTUSMART CM actuators contains 5g of factory supplied silica gel.

CAUTION: Please remove the silica gel before commissioning the actuator (see section 5, page 29).



3.2 Storage

CAUTION: Please observe the following measures to avoid damage during the storage of actuators:

- Store actuators in well-ventilated, dry premises.
- Protect against floor dampness by storing actuators on wooden grating, pallets, mesh boxes or shelves.
- Protect the actuators against dust and dirt with plastic foil.
- Actuators must be protected against mechanical damage.
- The storage temperature must be between -20°C and +40°C.

It is not necessary to open the controller of the actuator for servicing batteries or similar operations.

3.3 Long-term storage

CAUTION: If you intend to store the actuator for more than 6 months, additionally follow the instructions below:



- **CAUTION:** The silica gel in the connection compartment must be replaced after 6 months of storage (from date of delivery from SCHIEBEL's factory in Vienna).
- After replacing the silica gel, brush the connection cover seal with glycerine. Then, carefully close the connection compartment again.
- Coat screw heads and bare spots with neutral grease or long-term corrosion protection.
- Renovate damaged paintwork arising from transport, improper storage, or mechanical influences.

CAUTION: For explosion-proof actuators, it is not allowed to extensively overpaint the actuator. According to the standard, in order to avoid electrostatic charge, the maximal thickness of the varnish is limited to 200 μm .

- Every 6 months, all measures and precautions for long-term storage must be checked for effectiveness, and corrosion protection and silica gel must be renewed.
- Failure to follow the above instructions may lead to condensation which can damage the actuator.

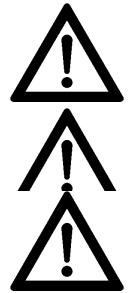

4 Installation instructions



Bild 17: 1... mounting flange, 2... bore pattern G0/F10, 3... centring ring, 4... bore pattern F07, 5... shaft connection, 6... ground connection

Installation work of any kind on the actuator may only be performed by qualified personnel.

4.1 Mechanical connection

see Bild 17, page 25

Check whether the valve flange, actuator flange and valve shaft correspond to the shaft connector of the actuator. For output type "Äm"(threaded bushing with bore), check whether the thread of the valve matches the

thread of the actuator.

In general, proceed as follows:

- Clean the bare parts of the actuator uncoated with corrosion protection.
- Thoroughly clean the screw mounting surfaces of the valve.
- In the actuator, appropriately lubricate the output shaft and the valve of the driven shaft.
- In the "Äm"-version, ensure that the valve bushing is amply lubricated.
- Attach the actuator to the valve or gearbox.
- Tighten fastening screws (torque according to table below).
- By means of the handwheel, check the ease of movement of the actuator-valve connection.

Thread	Tightening [Nm] for screws with strength class	
	8.8	A2-70 / A4-70
M6	11	8
M8	25	18
M10	51	36
M12	87	61
M16	214	150
M20	431	294
M30	1489	564

For output type A (unbored threaded bushing), you must sufficiently lubricate both needle bearings in the output form after processing and cleaning the spindle nut.

For this purpose, use the optional SCHIEBEL grease lubricant or a grease lubricant according to our recommendation (see section 15.3, page 69).

4.2 Mounting position of the operating unit

The mounting position of the operating unit can be rotated in 90° steps.



Bild 18

- Disconnect the actuator and control system from the power supply.

- To prevent damage to the electronic components, both the control system and the person have to be earthed!
- Unscrew the bolts for the interface surface and carefully remove the service cover.
- Turn service cover to new position and put back on.

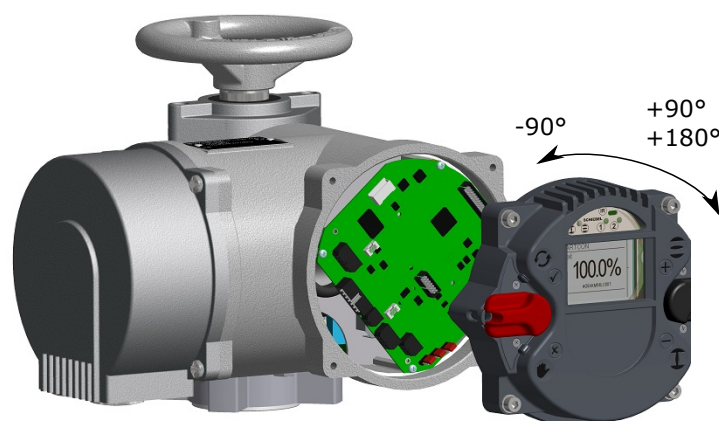

- Ensure correct position of the O-ring.
- Turn service cover by max. of 180°.
- Put service cover on carefully so that no cables get wedged in.



- Screw the bolts shut evenly in a crosswise sequence. IMPORTANT: max. torque 5 Nm



4.3 Electrical connection

Electrical connections may only be carried out by qualified personnel. Please observe all relevant national security requirements, guidelines, and regulations. The equipment should be de-energized before working on electrical connections. Furthermore, confirm the absence of electrostatic discharges during the connection. First of all, connect the ground screw.



The line and short circuit protection must be done on the system side. The ability to unlock the actuator for maintenance purposes must be provided. For the dimensioning, the rated current is to be used (see Technical Data).



Check whether the power supply (voltage, frequency) is consistent with the connection data (see type label – Bild 10, page 21). The connection of electrical wiring must follow the circuit diagram. This can be found in the appendix of the documentation. The circuit diagram can be ordered from SCHIEBEL by specifying the serial number. When using options, such as a Profibus connection, the relevant guidelines must be followed.



4.3.1 Power supply connection

ACTUSMART CM actuators feature an integrated motor controller, i.e. only a connection to the power supply is required. In **non explosion-proof actuators**, the wiring uses a connector independent from control signals (see Bild 19, page 28).



Bild 19: 1... Metric screw M32x1,5, 2... M40x1,5, 3... M25x1,5, 4... Plug insert Han6E (for power supply), 5... Plug insert Han24E (for control cables), 6... Connector for options, 7... Connector plate, 8... Connecting housing

The connection on **explosion-proof actuators** or, on special request also on non explosion-proof actuators) will be made via terminals (see Bild 20).

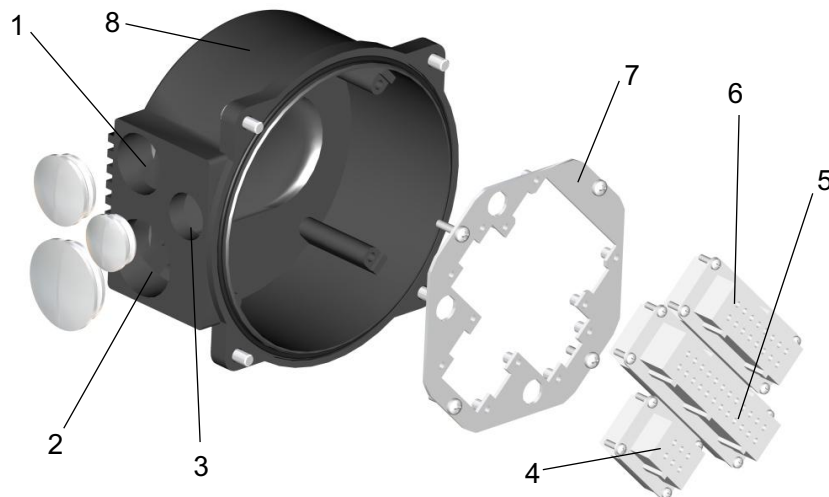

Bild 20: Terminal box: 1... Metric screw M40x1,5, 2... 2 pcs. M20x1,5, 3... Terminals for the control signals, 4... Terminals for the power supply, 5... Terminal for ground connection, 6... Outside ground connection

If, during outdoor installation, commissioning is not carried out immediately after electrical connection, the power supply must be connected at a minimum to achieve a heating effect. In this case, the silica gel may remain in the connection compartment until commissioning.

CAUTION: see section 3.3, page 24

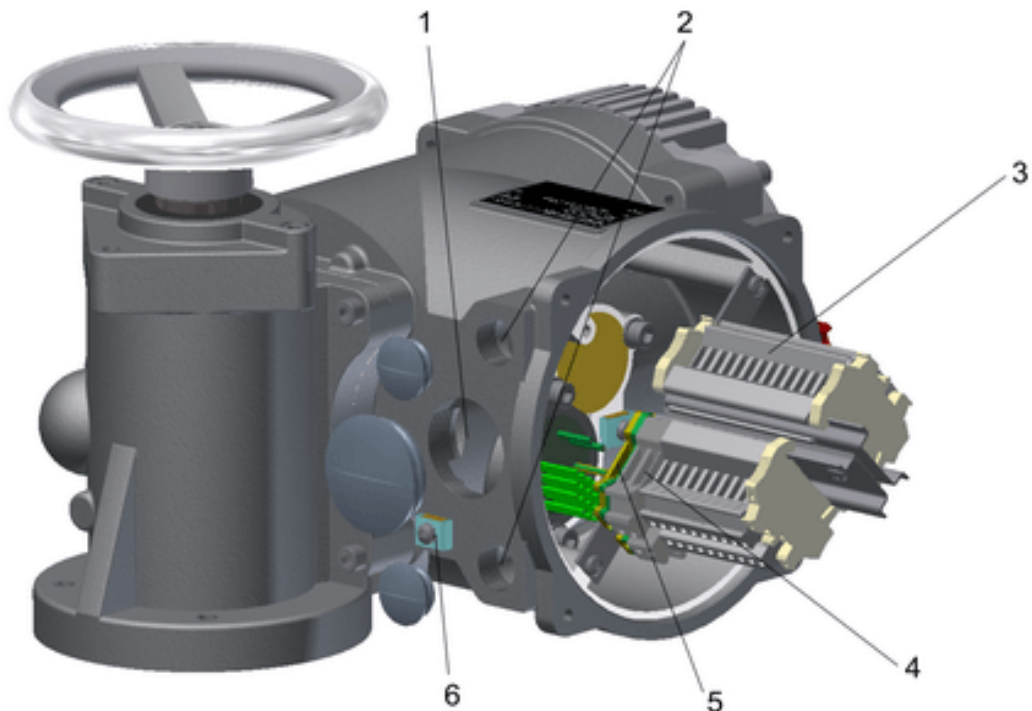

5 Commissioning

Before commissioning, ensure that the actuator is correctly assembled and electrically connected (see section 4, page 25).

CAUTION: Remove silica gel from the connection compartment.

5.1 General

CAUTION: During commissioning and after every disassembly of the actuator, the electric end positions (see section 5.4, page 29) must be reset.



5.2 Manual operation

The use of a differential gearbox in the handwheel assembly makes mechanical switching unnecessary during manual operation.

CAUTION: Manual operation with mechanical or electromechanical equipment (such as: lever, drilling machine, etc.) is NOT ALLOWED, as this may damage the product.



5.3 Mechanical default settings, preparation

The use of multi-turn sensors makes mechanical settings unnecessary.

CAUTION: Before the motorised operation of the valve, it is essential to check and eventually adjust torque settings.



5.4 End limit setting

A detailed description of the operation of the ACTUSMART CM controller can be found in section 6.3, page 35.

5.4.1 End limit OPEN

Set the selector switch and control switch to the center position.



Bild 21: 1... Selector switch (red), 2... Control switch (black)

Scroll through the menu with the control switch. Move the control switch towards the first menu item ⊖ "P 1.1 End limit – Open".



Bild 22

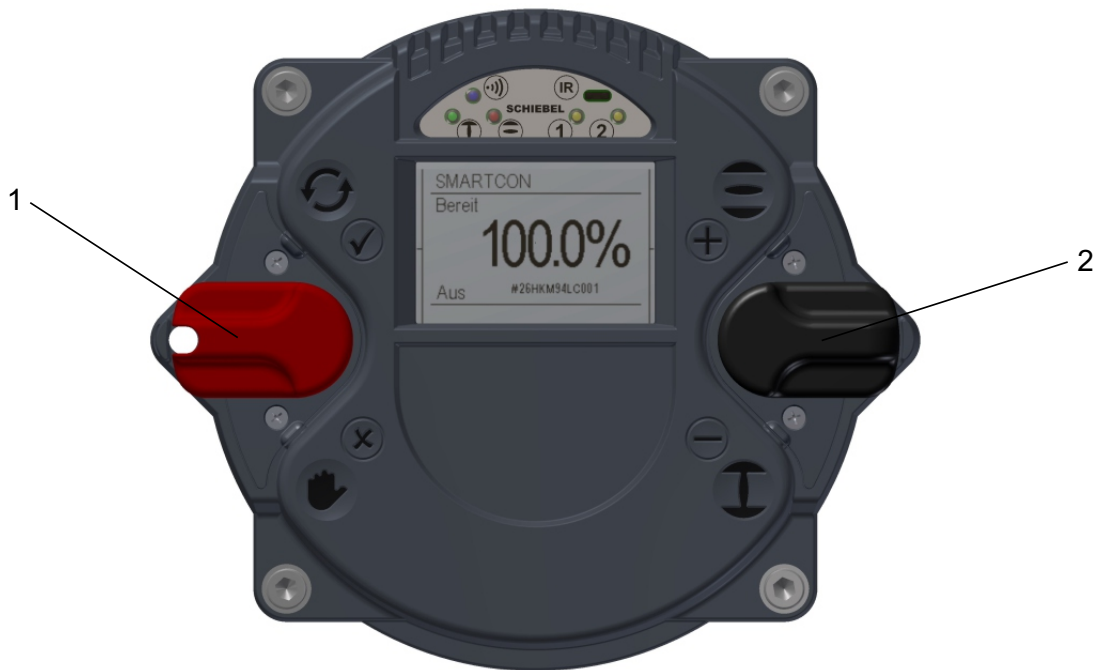

Bild 23

Afterwards, flip up the selector switch slightly and let it snap back to its neutral position ✓.

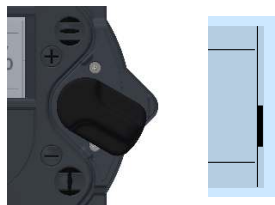

Bild 24

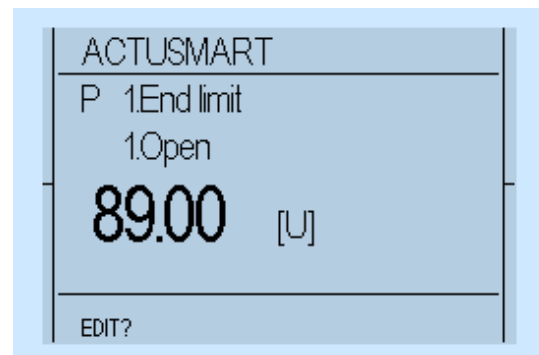

Bild 25



Bild 26

This changes the bottom line of the display from EDIT?" to SSAVE?"

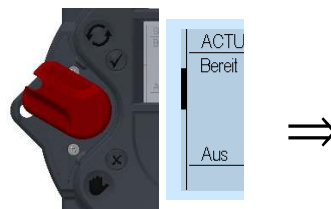

Bild 27

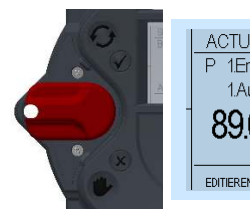

Bild 28

Then, push down the selector switch until it snaps into place. In doing so, the bottom right now on the display will show "TEACHIN"⊗

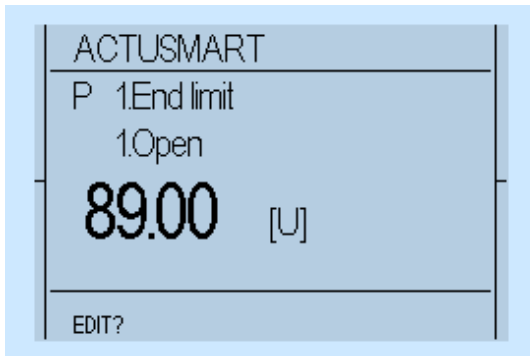
CAUTION: Once the display shows "TEACHIN", use the operating switch (black switch) to start the motorised operation of the actuator. In this mode, no travel-dependent switch off occurs in the end position.

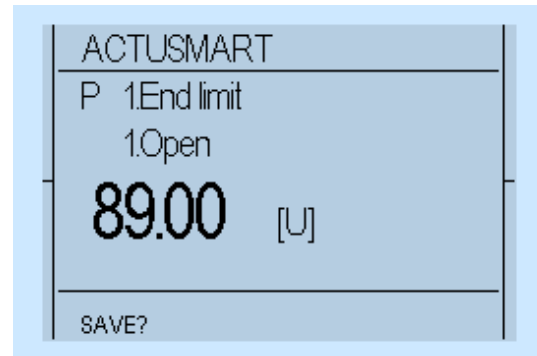

CAUTION: Please note that, during motor operation, only torque monitoring remains active, as travel adjustment will happen subsequently. Therefore, please check beforehand whether the maximum torque has been already parameterised.



Absolute and relative values on the display will change continuously along with position changes.



Bild 29



Bild 30

Manually move the actuator with the handwheel (see section 2.1, page 20, or section 2.6, page 22) or by motor via the operating switch (black switch) to the end position OPEN of the valve.

- Absolute value: Absolute value of the position feedback
- Relative value: The value to the other end position

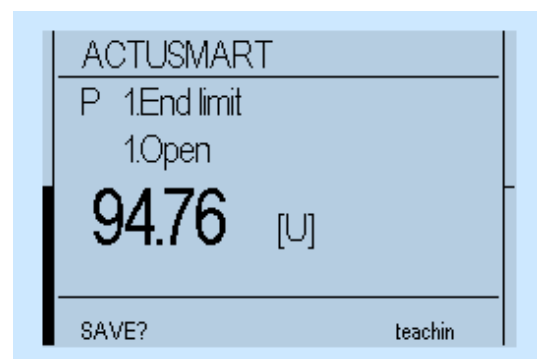

Bild 31: 1... Absolute value, 2... Relative value

When the desired end position OPEN of the valve is reached, move the selector switch back to the middle position. Thus, the line "TEACHIN" disappears.



Bild 32

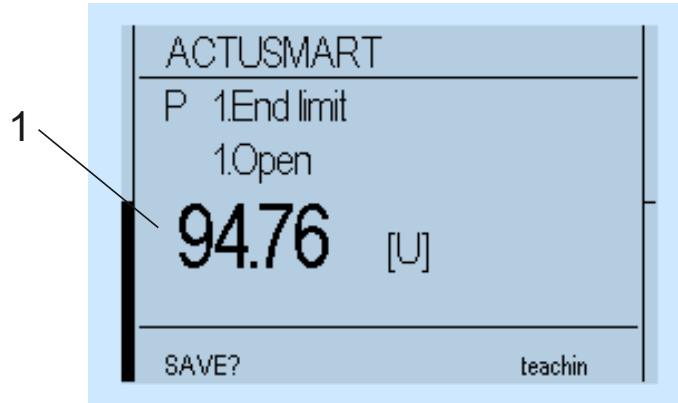

Bild 33

In order to confirm the end position (save), slightly flip up the selector switch towards ☑ and let it snap back to its neutral position.

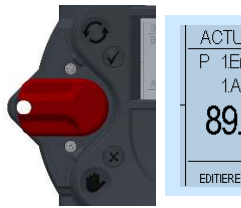

Bild 34

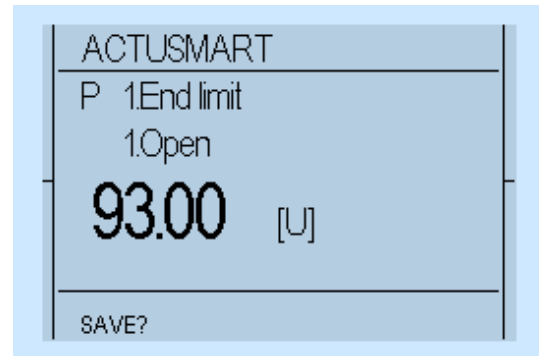

Bild 35

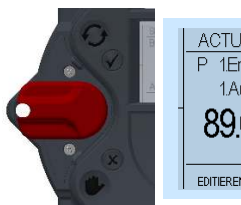

Bild 36

This changes the bottom line of the display for "SSAVE?" to "EDIT?" and the end position is stored.

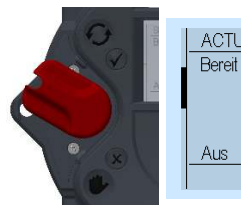

Bild 37



Bild 38

5.4.2 End limit CLOSE

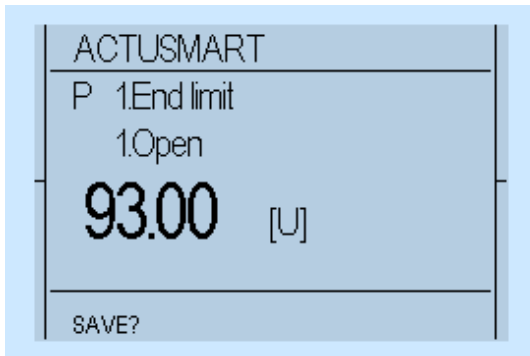
Use menu item "P 1.2 End limit - End limit CLOSEäs for End limit OPEN

5.5 Final works

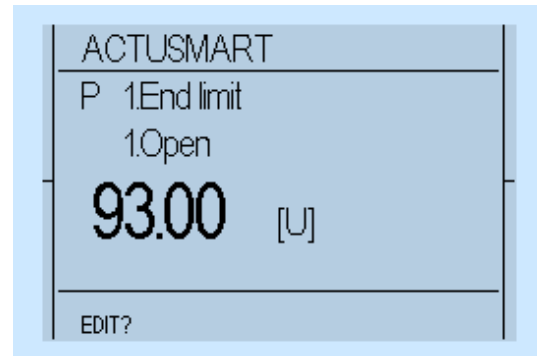
Following commissioning, check for proper sealing the covers to be closed and cable inlets (see section 2.4, page 21). Check actuator for paint damage (by transport or installation) and repair if necessary.

6 Control Unit

The controller is intended to monitor and control the actuator and provides the interface between the operator, the control system and the actuator.

6.1 Operating unit

Operation relies on two switches: the control switch and a padlock-protected selector switch. Information visualization is provided by 4 integrated indicator lights, as well as the graphic display. For better visibility, switch symbols (✓, ✗, ⊕, ⊖) are on the cover



Bild 39: 1... Selector switch, 2... Control switch, 3... Graphic display, 4... LED display

The controller switches serve on the one hand for electric-motor operation of the actuator and, on the other

hand, to configure and view various menu items.

The controller cover may be wiped clean with a damp cloth.

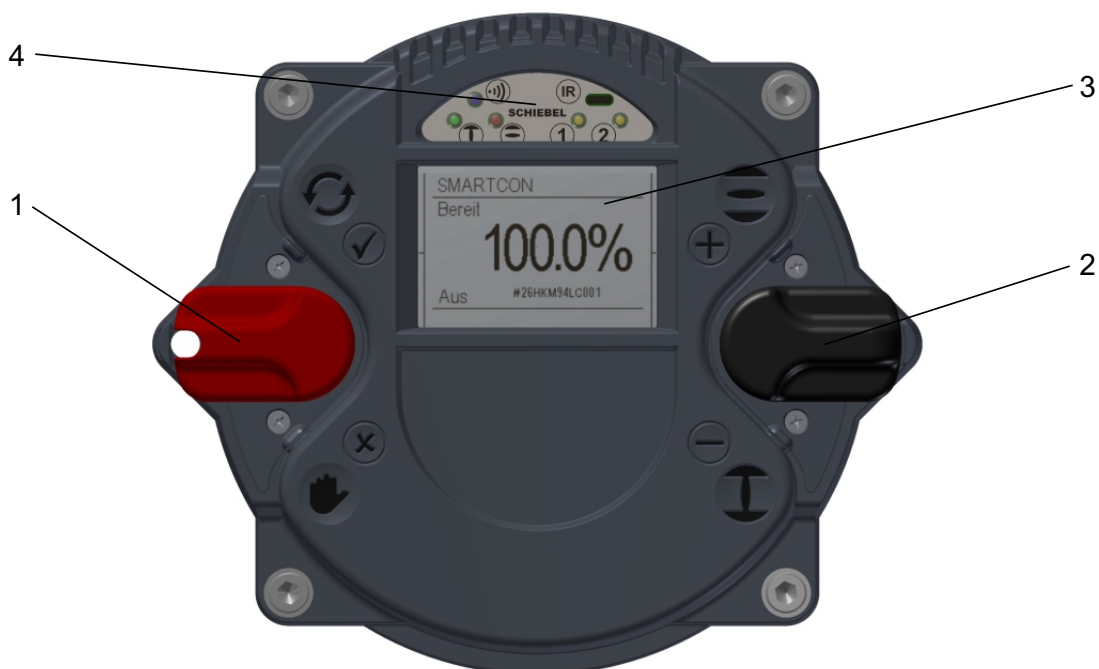
The mounting position of the control unit can be turned in 90° steps (see section 4.2, page 26).

6.2 Display elements

6.2.1 Graphic display

The graphic display used in the controller allows text display in different languages.



Bild 40

During operation, the displays shows the position of the actuator as a percentage, operation mode and status. When using the option 'identification', a customer-specific label is shown at the bottom of the display (e.g., PPS Number).

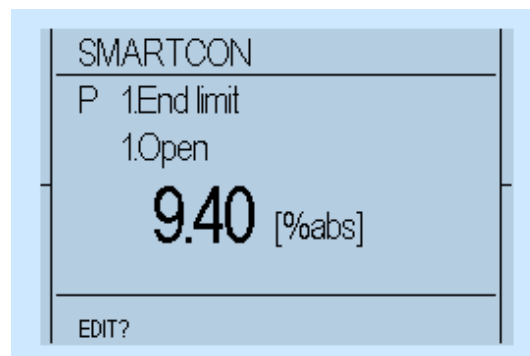

Bild 41: 1... Status, 2... Operation mode, 3... Position

6.2.2 LED Display

To provide users with better status information, basic status data is displayed using 4-colour LEDs. As the device powers up, it undertakes a self-test whereby all 4 LEDs briefly lit up simultaneously.

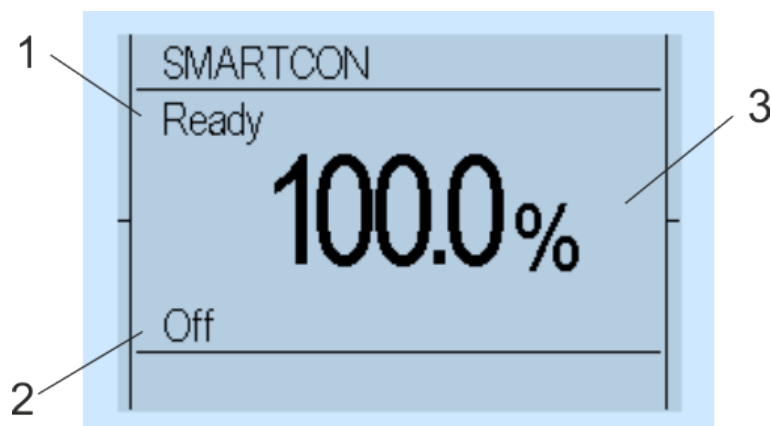

Bild 42

Description	Colour	Lits up	Flashes quickly	Flashes slowly	Does not light up
L1	Yellow	No torque error	Torque fault	—	¹⁾
L2	Yellow	Ready (operational readiness)	Travel fault (no operational readiness!)	—	Error (no operational readiness) motor temperature, supply voltage absent, internal error ¹⁾
L3	Green ²⁾	CLOSE ³⁾	Moving to CLOSE position	Applies upon torque-dependent closing: Occurs when the end position CLOSE is reached but the cut-out torque has not yet been reached	Actuator is not in the CLOSE position.
L4	Red ²⁾	OPEN ³⁾	Moving to OPEN position	Applies upon torque-dependent opening: Occurs when the end position OPEN is reached but the cut-out torque has not yet been reached	Actuator is not in the OPEN position.
L5	Blue	Bluetooth connected	Bluetooth data transmission	Bluetooth ON, not connected	Bluetooth/Infrared OFF
	Red	Infrared connected	Infrared data transmission	Infrared ON, not connected	

6.3 Operation

The actuator is operated via the switches located on the controller (selection- and control switch). All actuator settings can be entered with these switches. Furthermore, configuration is also possible via the IR interface or the Bluetooth Interface (see section 9, page 63). Flip the switch up or down to regulate the parameter menu scrolling speed.

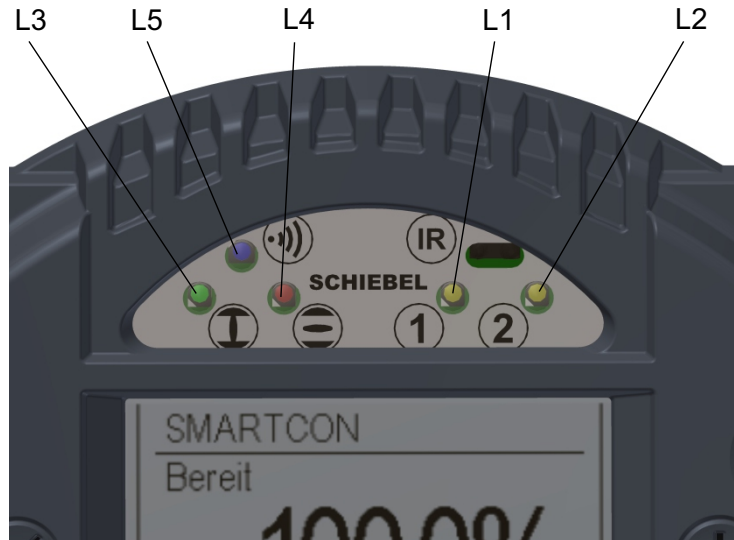
¹⁾LED L1 and L2 are turned off as long as an infrared connection is active.

²⁾Colour of LED L3 and L4 can be changed by parameter P1.7 - see section 7.1, page 40.

³⁾A travel fault is indicated by a lit L3 and L4



Bild 43: Neutral position



Bild 44: Slight switch flip (it will move to the next parameter)

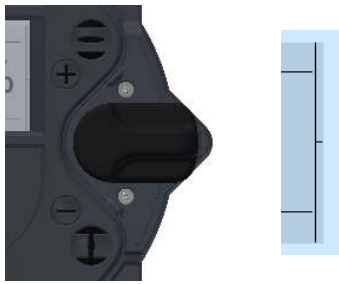

Bild 45: halfway switch flip (it will jump to the next parameter category)



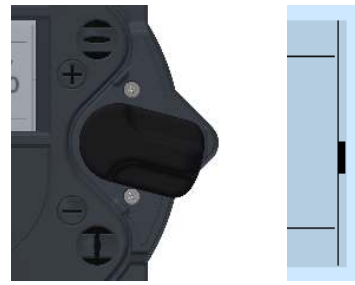

Bild 46: Full switch flip (it will jump to the end of the menu)

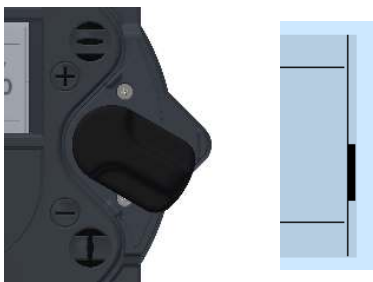
6.3.1 Operation mode

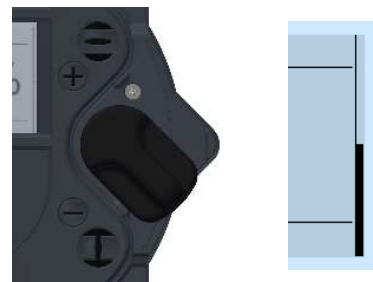

Use the selector switch (red) to determine the various operating states of the actuator. In each of these positions, it is possible to block the switch by means of a padlock and thus protect the actuator against unauthorized access.

The selector switch has the following positions:

OFF	The actuator can be neither operated via the remote control nor via the control switches of the controller.
Local 	It is possible to operate the actuator by motor via the control switch. Control via the remote inputs may be possible with appropriate configuration (superimposed control commands, emergency commands)
Remote 	The actuator is ready to process control commands via input signals. The control switch for the motor operation of the actuator is not enabled.

Besides defining the operational status, the selector switch is used in configuration mode to confirm or cancel parameter inputs.

Depending on the selector switch position, the control switch performs different functions:

Selector switch in the OFF position:	The control switch is used to scroll up or down the menu according to internal symbolism. From the neutral position towards \oplus you reach the status and history data areas. Towards the \ominus symbols you reach the parameter menu. Here, the selection switch either confirms \checkmark or rejects \otimes the current input according to associated symbolism.
Selector switch in the REMOTE position 	The control switch gives you access to status, history data and parameter area.
Selector switch in the LOCAL position 	With the control switch, the actuator can be operated by motor. You may also operate the actuator in inching and self-hold mode. Switches are spring-loaded to snap back automatically into their neutral position. (To confirm a control command, the control switch must be pushed all the way into its mechanical locking position.)

6.3.2 Configuration

In principle, all parameters are shown as numbers in the corresponding parameter point. From the actuator menu, use the control switch to access different menu points. The lower left corner of the display shows the EDIT option.



Bild 47

Confirm the selector switch (with a slight flip towards \checkmark , (see Bild 34, page 32 to Bild 36, page 32) to change the selected parameter. To confirm this input readiness, the display changes from EDIT"to SSAVE".

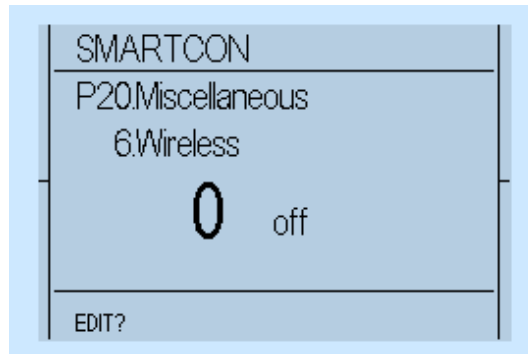

Bild 48

Use the control switch towards to the characters to change the parameter. \oplus or \ominus (see Bild 43 til Bild 46, page 36) After reaching the desired parameter value, confirm the value with the selector switch (again, flip it slightly towards \checkmark , (see Bild 34, page 32 til Bild 36, page 32).

6.3.3 Configuration example

By way of example, we will change parameter P20.6 (wireless) from 0 (wireless off) to 2 (Bluetooth communication on). Thus, the Bluetooth connection is activated for a short time and then deactivated again automatically:

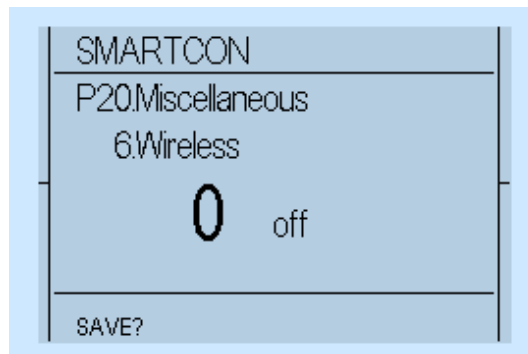
The operating and control switch must be in the neutral position



Bild 49: 1... Selector switch (red) , 2... Control switch (black)

Now, move the control switch down (towards) until the menu item "P 20.6 Miscellaneous - Wireless" is displayed.



Bild 50

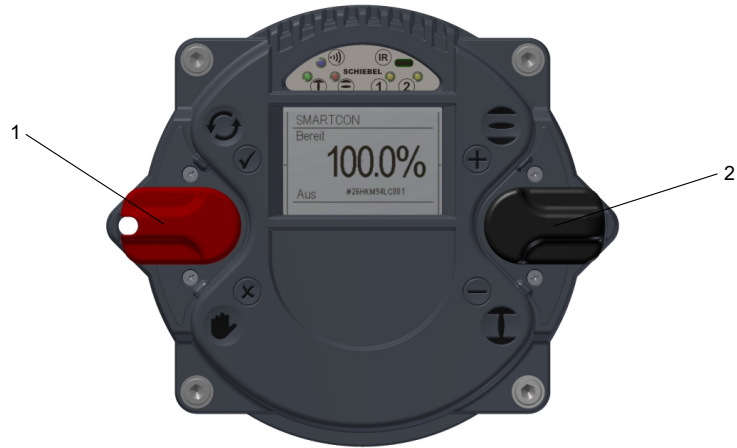

Bild 51

Afterwards, flip up slightly the selector switch (towards) and let it snap back to its neutral position

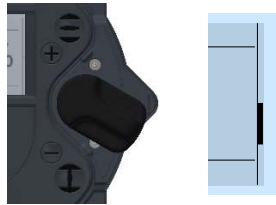

Bild 52

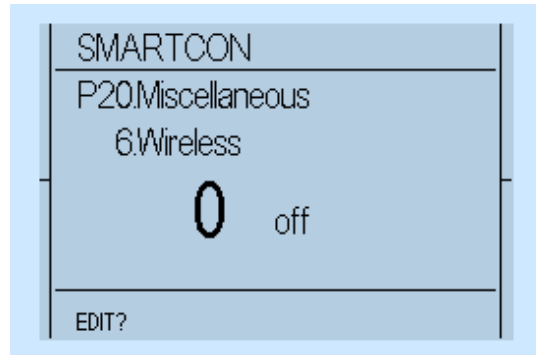

Bild 53



Bild 54

This changes the bottom line of the display from "EDIT?" to "SSAVE?"

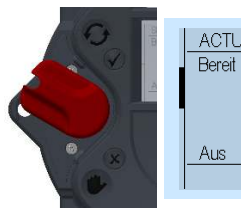

Bild 55

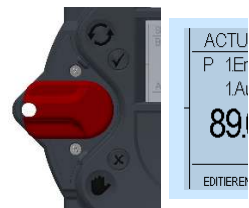

Bild 56

Thereafter, flip up the control switch (toward) to change the value from 0 (off) to 2 (Bluetooth)

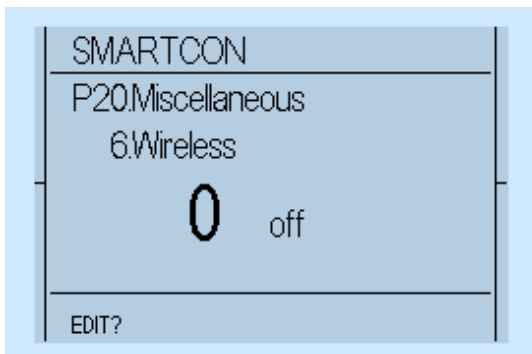

Bild 57

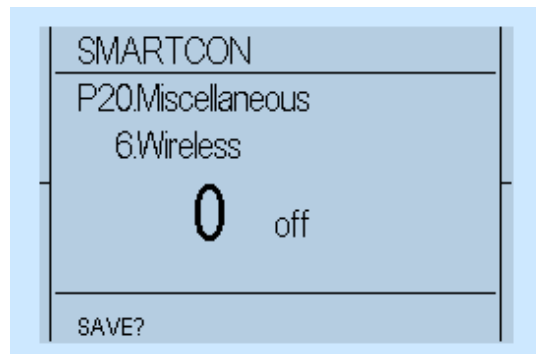

Bild 58

If the value changes to 1, confirm the selection by flipping halfway up the selector switch (towards) and letting it snap back to its neutral position (see Bild 52 til Bild 54).



Bild 59

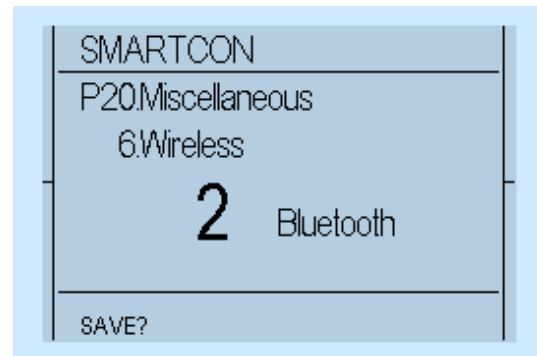

Bild 60

This changes the bottom line of the display from SSAVE?"to EDIT?"and the parameter is stored.

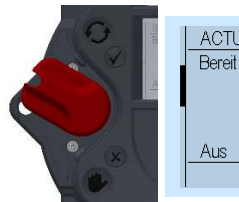
6.3.4 „TEACHIN“

Furthermore, certain parameters (end positions, intermediate positions).can be set using "TEACHIN". Thus, their configuration is greatly simplified.

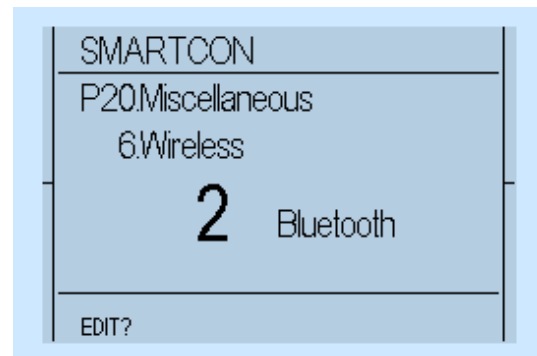
After selecting the appropriate menu item (for example: End position) and changing the the input type from EDIT?"to SSAVE?", move the selector switch (red) to "manual mode"and lock it into place. As you do so, the display will show the message "TEACHIN"and the current position value will be applied continuously to the parameter value. In this mode, further to manual operation by hand wheel, the actuator can be motor-driven with the control switch to the desired position. (see section 30, Bild 30, page 31)



Bild 61

CAUTION: Please note that, during motor operation, only torque monitoring remains active, as travel adjustment will happen subsequently. Therefore, please check beforehand whether the maximum torque has been already set.

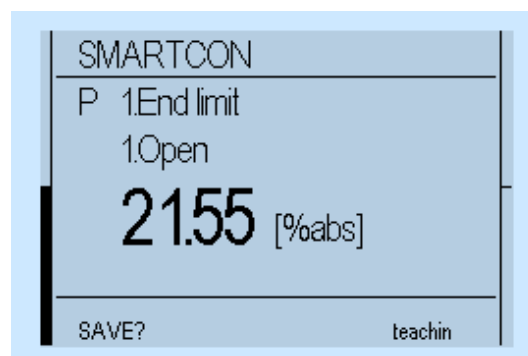

After reaching the desired, to-be-defined position, move the selector switch back to the neutral position. Finally, the parameter value must still be saved by flipping the selector switch halfway up and letting it snap back to the neutral position (see Bild 52 til Bild 54, page 38).

7 Parameter menu

For each parameter group, you can find a description, tabular overview of the menu items and possible configurations. The parameter list below also includes all possible options per menu item. Please note that some of the menu items listed and described may not be delivered with your configuration.

7.1 Parameter group: End limit

These parameters are used to configure the end position and switch off behavior of the actuator. In this regards, it is important to ensure that the basic mechanical configuration described in section 5.4, page 29 has already been made.

Ensure that these parameters are set during commissioning before operating the actuator. In addition, the settings in the "Torque" menu (see section 7.2, page 42 must be compared with the permissible values of the valve and corrected as appropriate)



CAUTION: Generally, 100% stands for fully open and 0% for fully closed. Please note that these values cannot be changed. The end position range is reached as soon as 0% or 100% is shown on display.



	Menu item	Sub-menu item	poss. setting	Notes / comments
P1.1	End limit	Open	TEACHIN; 0... 100 U ¹⁾	The parameter value can be set using TEACHIN. With a known travel, the second end position can be entered after setting the first end position.
P1.2	End limit	Close	TEACHIN; 0... 100 U ¹⁾	The parameter value can be set using TEACHIN. With a known travel, the second end position can be entered after setting the first end position.
P1.3	End limit	Switch-off Open	0: travel	The actuator uses end-position signals to switch off and report the end position. Attention: For failsafe-actuators in failsafe-direction not applicable. End limit by travel in failsafe-position only possible by changing the mechanical connection to the valve.
			1: torque	The actuator signals the end position or stops the motor only after reaching the specified torque in the end position. If the torque is reached and end position signal not, the actuator reports an error. If the end position is reached and the control command drops off during the build-up of the torque, the motor stops and the required torque is not reached. Attention: For failsafe-actuators in failsafe-direction not applicable. Torque/Force in failsafe-position depends on residual spring torque/force

continued on next page

¹⁾representative for CM03; U...number of revolutions

continued from previous page

	Menu item	Sub-menu item	poss. setting	Notes / Comments
			2: torque1	Like „torque“, but in the end position range, the torque is also increased when the control command drops off during the build-up of the torque, until the required torque is reached. Attention: For failsafe-actuators in failsafe-direction not applicable. Torque/Force in failsafe-position depends on residual spring torque/force
			3: torque2	Like „torque1“, but in the end position range automatically an additional control command is generated to reach and hold the torque. If the torque decrease and the actuator is in the end position it will be restored automatically. e.g.: Changes due to temperature differences, settlement. Attention: For failsafe-actuators in failsafe-direction not applicable. Torque/Force in failsafe-position depends on residual spring torque/force
			4: travel1	Like „travel“, however, the actuator still continues to drive the set Overrun time after reaching the end position, even when the positioning command is released. Only relevant if Overrun time (P1.10, P1.11) is greater than 0. Attention: For failsafe-actuators in failsafe-direction not applicable.
P1.4	End limit	Switch-off Close	1: travel	see P1.3
			1: torque	see P1.3
			2: torque1	see P1.3
			3: torque2	see P1.3
			4: travel1	see P1.3
P1.5	End limit	Closing direction	right (0)	Actuator is designed for clockwise = closing.
			left (1)	Reverse direction of rotation! Counterclockwise = closing. The crossing of all signals and commands is performed by the controller.
P1.6	End limit	Rot. sense pos.	0	Rotation sense of the Potentiometer. No function in ACTUSMART CM series.
			1	
P1.7	End limit	LED function	Close = green (0)	Definition of the LED colour of the CLOSED or OPEN end position signalization.
			Close = red (1)	
P1.8	End limit	End limit hyst.	0.1... 10.0%	Hysteresis range for end position signals: Example: End position hysteresis 1% means that the End position OFF is reached when closing 0%, and will be left when opening only at 1%, i.e., a re-closing can only take place after leaving this hysteresis.
P1.9	End limit	Ramp	0.1... 100%	When approaching the end position, the speed is reduced.

continued on next page

continued from previous page

	Menu item	Sub-menu item	poss. setting	Notes / Comments
P1.10	End limit	Range	0...100%	End position range for torque (P1.3, P1.4). Permissible range in which the torque is to be achieved. If the actuator comes to the end of the end position range, the motor shuts off even if the torque has not been reached.
P1.11	End limit	Overrun Open	0...60 s	Switch-off delay after reaching the end position see travel1 (P1.3, P1.4)
P1.12	End limit	Overrun Close	0...60 s	Switch-off delay after reaching the end position travel1 (P1.3, P1.4)

CAUTION: When installing the actuator on a gear or a thrust unit, please take into account the limits and factors of the gear / thrust unit at parametrization.



When using end-limit switch-off by torque, the end position limit must be set before reaching the torque limit. Accordingly, the actuator will only signal the final end position if the configured torque and the associated end position are reached. If the end position is not reached, a torque error is reported (see section 6.2.2, page 34).

7.2 Parameter group: Torque

If no torque was specified with the order, the actuator is supplied from the factory with the maximum configurable torque.

	Menu item	Sub-menu item	poss. setting	Notes / comments
P2.1	Torque	Open	8...32 Nm ²⁾	Switch-off torque in OPEN direction CAUTION: The range can be restricted via menu item P2.3.
P2.2	Torque	Close	8...32 Nm ²⁾	As P2.1, but in CLOSED direction.
P2.3	Torque	Torque limit	8...32 Nm ²⁾	Torque to protect the valve, the transmission, or the thrust unit. This value limits the setting of parameters P2.1 and P2.2 to prevent an erroneous increase above the allowed value of these two parameters.
P2.4	Torque	Latching	0: Off	Unassigned in ACTUSMART CM series

When installing the actuator on an additional gear, please take into account the corresponding values of the gear / thrust unit as you enter the actuator parameters. To achieve an effective output torque (incl. gear) / output power (including thrust unit) ratio, the factor gear/thrust unit must be considered.



²⁾representative for CM03

7.3 Parameter group: Speed

	Menu item	Sub-menu item	Poss. setting ²⁾	Notes / comments
P4.1	Speed	Local Open	2.5... 72.2 rpm	Output speed for local operation in direction OPEN.
P4.2	Speed	Local Close	2.5... 72.2 rpm	As P4.1, but in direction CLOSE.
P4.3	Speed	Remote Open	2.5... 72.2 rpm	Output speed for remote operation in direction OPEN.
P4.4	Speed	Remote Close	2.5... 72.2 rpm	As P4.3, but in direction CLOSE.
P4.5	Speed	Emergency Open	2.5... 72.2 rpm	Output speed for emergency operation in direction OPEN.
P4.6	Speed	Emergency Close	2.5... 72.2 rpm	As P4.5, but in direction CLOSE.
P4.7	Speed	Torque-dependent	2.5... 72.2 rpm	Seal-tight speed. Speed at which the actuator runs near the end position at torque-dependent switch-off (see P1.3 and P1.4).
P4.8	Speed	Minimum	2.5... 72.2 rpm	Minimum speed.

CAUTION: The max. speed for the 24 VDC actuator version is reduced to 20 rpm.



7.4 Parameter group: Ramp (optional)

The start ramp can be set separately for each operation mode. Thus, a 100% start ramp means that the motor attains its maximum speed in about a second. Higher speeds (see section 7.3) lead to shorter runtimes. If the ramp is set below 100%, the starting time increases in an inversely proportional fashion.

	Menu item	Sub-menu item	poss. setting	Notes / comments
P5.1	Ramp	Local	1... 100%	Start ramp for local operation
P5.2	Ramp	Remote	1... 100%	Start ramp for remote operation
P5.3	Ramp	Emergency	1... 100%	Start ramp for emergency operation

7.5 Parameter group: Control

	Menu item	Sub-menu item	poss. setting	Notes / comments
P6.2	Control	Ready delay	0... 10 sec	Drop-out delay for the ready signal (bin. outputs)
P6.5 ³⁾	Control	24 V output	0	24 V auxiliary output is deactivated (section 20.5, page 77). The function of the auxiliary input is still activated.
			1	24 V auxiliary output is activated (section 20.5, page 77).
P6.6	Control	Min. impuls	0.1... 2.0 sec	Minimum switch-on time of the motor.

7.6 Parameter group: Password

The actuator control can be password-protected to prevent access at different levels. It is possible to prevent entry by unauthorized personnel or to entirely lock motor operation. Default password is set to "000" and thus deactivated.

³⁾since firmware 1.303

You can use both numbers and capital letters in your password. After entering a password, password protection is activated. To remove password protection, enter an empty password (000).

When accessing a password-protected parameter, the user is automatically prompted for its introduction. Only after correctly entering the password, it is possible to change the corresponding parameters.

	Menu item	Sub-menu item	poss. setting	Notes / Comments
P7.1	Password	Reading PWD	3-digit	Status display and history data are still viewable; access to the parameter menu is locked until this password is introduced. Parameter menu scrolling is only enabled after entering the password. Electric motor operation is unlocked.
P7.2	Password	Writing PWD	3-digit	Status display, history data and parameter menu can be viewed. However, parameters become read-only.
P7.3	Password	Bluetooth PWD	15-digit	password for the Bluetooth connection, empty password deactivates the password request.

7.7 Parameter group: Position

In addition to OPEN and CLOSED end positions, you may define intermediate positions. These can be used as feedback signals for the binary outputs or as target value for fix position approach.

CAUTION: If you change the end positions (see section 7.1, page 40), intermediate positions are retained percentage-wise, i.e., the absolute positions of the intermediate positions change.



	Menu item	Sub-menu item	Poss. setting	Notes / comments
P8.1	Position	Intermed.pos.1	TEACHIN 0...100%	Position value of intermediate position 1
P8.2	Position	Intermed.pos.2	TEACHIN 0...100%	see above
P8.3	Position	Intermed.pos.3	TEACHIN 0...100%	see above
P8.4	Position	Intermed.pos.4	TEACHIN 0...100%	see above
P8.5	Position	Emerg.position	TEACHIN 0...100%	Position value of the emergency position.
P8.6	Position	Hysteresis	0.1...10.0%	Hysteresis range of intermediate positions. Within this hysteresis, no repositioning occurs upon reaching the intermediate positions (option: fix position approach). Furthermore, the output functions for position = intermediate position are active within this range (see P10.1 ...).

7.8 Parameter group: Binary inputs

The controller is equipped with 5 freely configurable binary inputs. Please find further information on technical data of the binary inputs in section 20.2, page 74. Binary inputs are also effective during actuator control via Profibus (option).

Default binary inputs are as follows:

Input 1: OPEN

Input 2: CLOSED

Input 3: STOP

Input 4: EMERGENCY OPEN

Input 5: EMERGENCY Closed

	Menu item	Sub-menu item	poss. setting	Notes / comments
P9.1	Bin. Input	Input 1	0: no function	this input has no function
			1: Open	OPEN command in REMOTE mode (selector switch in position REMOTE).
			2: Closed	CLOSED command in REMOTE mode (selector switch in position REMOTE).
			3: Stop	STOP command in REMOTE mode (selector switch in position REMOTE).
			4: Open Self-hold	Self-hold for OPEN, i.e., a short pulse is sufficient and the actuator moves then into the end position. Use the STOP command to stop the actuator.
			5: Closed Self hold	Self-hold for CLOSED, see OPEN SELF-HOLD
			6: Emergency Open	Superimposed run command; run the actuator in direction OPEN regardless of whether the selection switch is set to REMOTE or LOCAL operation
			7: Emergency Closed	Superimposed run command; run the actuator in direction CLOSED regardless of whether the selection switch is set to REMOTE or LOCAL
			8: Release	The actuator may be operated only with a switched signal. Both in local and remote operation
			9: Open/Closed	The actuator moves towards OPEN if input is active and towards CLOSED otherwise
			10: Close/Open	The actuator moves towards CLOSED if input is active and towards OPEN otherwise
			11: Positioner	Release of the positioner
			12: Open inv.	As open but active low
			13: Close inv.	As CLOSED but active low
			14: Stop inv.	As STOP but active low
			15: Open Self-Hold.inv	As Open Self-Hold but active low
			16: Closed Self-Hold inv	As Closed Self-Hold. but active low
			17: Emergency-Open inv.	As Emergency-Open but active low
			18: Emergency-Closed inv.	As Emergency-Closed but active low
			19: Block	with activated (switched) signal, the actuator is locked for operation also in local mode
			20: Contoller lock	Positioner lock
			21: Release Local	The actuator may be operated only with a switched signal.
			22: Block Local	as Release Local but active low
23: Lock Open	Trigger lock OPEN (in LOCAL and REMOTE mode). Actuator moves with the highest priority to OPEN; command continues internally active after reaching the end position OPEN. Dropping only with LOCK OFF, Supply OFF or operating mode OFF.			

continued on next page

continued from previous page

	Menu item	Sub-menu item	poss. setting	Notes / comments
			24: Lock Closed	Trigger lock CLOSED (in LOCAL and REMOTE mode). Actuator moves with the highest priority to CLOSED; command continues internally active after reaching the end position CLOSED. Dropping only with LOCK OFF, Supply OFF or operating mode OFF.
			25: Lock Off	Drop the lock
			26: Failsafe	Trigger the failsafe function in all operating modes (only functional in Failsafe actuators).
			27: Failsafe inv.	As Failsafe, but active low
			28: Lock Open inv.	As Lock Open, but active low
			29: Lock Closed inv	As Lock Closed, but active low
			30: Lock Off inv.	As Lock Off, but active low
			31: Intermediate position1	Approach intermediate position 1 (P8.1) in REMOTE mode (fix position approach). There is no repositioning upon reaching the intermediate position within the hysteresis (see P8.6). Higher priority than intermediate position 2, 3 and 4
			32: Intermediate position2	As intermediate position 1, but with higher priority than intermediate positions 3 and 4
			33: Intermediate position3	As intermediate position 1, but with higher priority than intermediate position 4
			34: Intermediate position4	As intermediate position 1, but with lowest priority.
			35: Emergency position	Approach emergency position (P 8.5). As intermediate position 1, but with higher priority than intermediate positions 1, 2
			36: Intermediate position1 inv.	As Intermediate position 1, but active low
			37: Intermediate position2 inv.	As Intermediate position 2, but active low
			38: Intermediate position3 inv.	As Intermediate position 3, but active low
			39: Intermediate position4 inv.	As Intermediate position 4, but active low
			40: Emergency position inv.	As Emergency position, but active low
			41: Travel Open	reserved for future use
			42: Travel Close	reserved for future use
			43: Travel Open inv.	reserved for future use
			44: Travel Close inv.	reserved for future use
			45: Failsafe lock	reserved for future use (only for Failsafe actuators)
			46: Failsafe lock inv.	reserved for future use (only for Failsafe actuators)
P9.2	Bin. Input	Input 2	see Input 1	
P9.3	Bin. Input	Input 3	see Input 1	

continued on next page

continued from previous page

	Menu item	Sub-menu item	poss. setting	Notes / comments
P9.4	Bin. Input	Input 4	see Input 1	
P9.5	Bin. Input	Input 5	see Input 1	

7.9 Parameter group: Binary outputs

The controller is equipped with 8 freely configurable binary outputs. Please find further information on technical data of the binary outputs in section 20.1, page 74. Provided with external supply, binary outputs are optically isolated from the rest of the controller.

Default binary outputs are as follows:

Output 1: Ready	Output 2: End position OPEN
Output 3: End position CLOSED	Output 4: Run OPEN
Output 5: Run CLOSED	Output 6: Torque
Output 7: LOCAL	Output 8: REMOTE

	Menu item	Sub-menu item	poss. setting	Notes / comments
P10.1	Bin. Output	Output 1	0: User defined	Optional
			1: Ready	Actuator is ready
			2: Fault	General fault; actuator is not ready
			3: Open	Actuator is in open position
			4: Closed	Actuator is in closed position
			5: Running Open	Actuators runs in direction Open
			6: Running Closed	Actuators runs in direction Closed
			7: Runing	Actuator is running in either Open or Closed
			8: Torque Open	Switch-off torque was reached in Open direction, actuator has been switched off
			9: Torque Closed	Switch-off torque was reached in Closed direction, actuator has been switched off
			10: Torque	Switch-off torque was reached in either Closed or Open direction
			11: Travel Open	The Open end position has been reached
			12: Travel Closed	The Closed end position has been reached
			13: Pos. > Int.1	Position > Intermediate position 1
			14: Pos. < Int.1	Position < Intermediate position 1
			15: Pos. > Int.2	Position > Intermediate position 2
			16: Pos. < Int.2	Position < Intermediate position 2
			17: Pos. > Int.3	Position > Intermediate position 3
			18: Pos. < Int.3	Position < Intermediate position 3
			19: Pos. > Int.4	Position > Intermediate position 4
			20: Pos. < Int.4	Position < Intermediate position 4
			21: Local	Local operating mode (selector switch in position)
			22: Remote	Remote operating mode (selector switch in position Remote)
23: Off	Off operating mode (selector switch in the Off position)			

continued on next page

continued from previous page

Menu item	Sub-menu item	poss. setting	Notes / comments
		24: no function	no function
		25: motor error	The motor temperature sensor has reported an error
		26: Always	Signal is always on
		27: Never	Signal is always off
		28: Bin. Input 1	Forwarding of binary input to output
		29: Bin. Input 2	Forwarding of binary input to output
		30: Bin. Input 3	Forwarding of binary input to output
		31: Bin. Input 4	Forwarding of binary input to output
		32: Bin. Input 5	Forwarding of binary input to output
		33: Torque Open ma.	As Torque OPEN, but it will suppress (mask) this signal in the end position upon torque-dependent switch-off.
		34: Torque Closed ma.	As Torque CLOSED, but it will suppress (mask) this signal in the end position upon torque-dependent switch-off.
		35: Ready Remote	Ready and Remote operating mode
		36: Ready Local	Ready and Local operating mode
		37: Ready Local/remote	Ready and Local or Remote mode
		38: Lock Open	Lock OPEN is enabled. OPEN command is internally queued with the highest priority and will not be dropped even in the end position.
		39: Lock Closed	Lock CLOSED is enabled. CLOSED command is internally queued with the highest priority and will not be dropped even in the end position.
		40: Failsafe OK1	Failsafe OK (only for Failsafe actuators)
		41: Failsafe OK2	Failsafe OK and Ready (only for Failsafe actuators)
		42: Failsafe OK3	Failsafe OK, Ready and Remote (only for Failsafe actuators)
		43: Lock	Lock Open or Lock Closed is enabled.
		44: Ready/TorqueOK	Actuator is ready and no torque switch-off
		45: Ready / Remote / TorqueOK	Actuator is ready for operation in REMOTE mode and no torque switch-off
		46: Pos.=Int1	Position = Intermediate position 1. The width of the interval is set with the parameter P8.6.
		47: Pos.=Int2	Position = Intermediate position 2. The width of the interval is set in parameter P8.6.
		48: Pos.=Int3	Position = Intermediate position 3. The width of the interval is set in parameter P8.6.
		49: Pos.=Int4	Position = Intermediate position 4. The width of the interval is set in parameter P8.6.
		50: Pos.=EmergPos	Position = emergency position. The width of the interval is set in parameter P8.6.

continued on next page

continued from previous page

	Menu item	Sub-menu item	poss. setting	Notes / comments
			51: Bus Bit 1	In existing bus interface (hardware option), the output is set according to the selected bit bus. ⁴⁾
			52: Bus Bit 2	
			53: Bus Bit 3	
			54: Bus Bit 4	
			55: Bus Bit 5	
			56: Bus Bit 6	
			57: Bus Bit 7	
			58: Bus Bit 8	
			59: Virtual 1	Configurable output function
			60: Virtual 2	
			61: Virtual 3	
			62: Virtual 4	
			63: Line voltage OK	Supply voltage for the motor is OK
			64: Control voltage OK	The auxiliary voltage for the SMARTCON control is OK. This function is only available if the auxiliary voltage output is not switched on (P6.5 to 0).
			65: Oil pressure OK	The oil pressure is higher than the minimum pressure (P6.10).
			66: Oil level OK	The oil level is OK.
			67: pump OK	The temperature sensor in the pump motor and the external motor protection have not tripped.
4-5 P10.2	Bin. Output	Output conf. 1	0: normal	Output 1 is set to normal, i.e. if the condition in point P10.1 is met, Output 1 is set to HIGH (active HIGH).
			1: inverted	If the condition in point P10.1 is met, Output 1 is set to LOW (active LOW).
			2: norm. flashing	If the condition in point P10.1 is met, Output 1 starts blinking (active HIGH).
			3: inv. flashing	If the condition in point P10.1 is not met, Output 1 starts blinking (otherwise it is set to HIGH).
P10.3	Bin. Output	Output 2	see Output 1	
P10.4	Bin. Output	Output 2 Konf.	see Output 1 conf.	
P10.5	Bin. Output	Output 3	see Output 1	
P10.6	Bin. Output	Output 3 Konf.	see Output 1 conf.	
P10.7	Bin. Output	Output 4	see Output 1	
P10.8	Bin. Output	Output 4 Konf.	see Output 1 conf.	
P10.9	Bin. Output	Output 5	see Output 1	
P10.10	Bin. Output	Output 5 Konf.	see Output 1 conf.	
P10.11	Bin. Output	Output 6	see Output 1	
P10.12	Bin. Output	Output 6 Konf.	see Output 1 conf.	

continued on next page

⁴⁾from Firmware 1.323

continued from previous page

	Menu item	Sub-menu item	poss. setting	Notes / comments
P10.13	Bin. Output	Output 7	see Output 1	
P10.14	Bin. Output	Output 7 Konf.	see Output 1 conf.	
P10.15	Bin. Output	Output 8	see Output 1	
P10.16	Bin. Output	Output 8 Konf.	see Output 1 conf.	

CAUTION: When using the parameters torque-dependent OPEN or torque-dependent CLOSED (see section 7.1, page 40, items P1.3 and P1.4), the actuator will only be open or closed when the set torque and the associated end position is reached. If the end position is not reached, a torque error is reported (see section 6.2.2, page 34).



7.10 Parameter group: Position output (optional)

Position output is used to indicate the current position of the actuator using 0/4...20 mA; it can be retrofitted using a Smartcode.

If this option is not enabled, the menu point shows the message "inactive".

No adjustment to the end positions or the travel is required. Adjustment is automatically performed during the configuration of travel limit positions (see section 7.1, page 40).

No further settings are necessary for torque-dependent switch-off, because the controller exclusively uses travel limit positions for the calculation, regardless of whether this is defined by the torque or the travel limit positions.

The factory default setting is:

4 mA at 0% position

20 mA at 100% position

	Menu item	Sub-menu item	poss. setting	Notes / comments
P11.1	Position-Output	Function 1	0: off	mA output disabled
			1: Position	mA output corresponds to the actual position value.
			2: Pos. Valvechar.	mA output corresponds to the actual position value taking into account the valve characteristic.
			3: Torque 1	mA output corresponds to the actual torque value.
				torque = 100% Close: mA output = start
				torque = 0%: mA output = center
				torque = 100% Open: mA output = end
			4: Torque 2	mA output corresponds to the actual torque value.
				torque = 100% Close: mA output = end
				torque = 0%: mA output = start
				torque = 100% Open: mA output = end
			5: Torque 3	mA output corresponds to the actual torque value.
				torque = 150% Close: mA output = start
				torque = 0%: mA output = center
	torque = 150% Open: mA output = end			
	6: Torque 4	mA output corresponds to the actual torque value.		
		torque = 150% Close: mA output = end		

continued on next page

continued from previous page

	Menu item	Sub-menu item	poss. setting	Notes / comments
				torque = 0%: mA output = start
				torque = 150% Open: mA output = end
P11.2	Position output	Begin 1 (at 0%)	0...20.5 mA {4 mA}	mA value for the Closed (0%) position
P11.3	Position output	End 1 (at 100%)	0...20.5 mA {20 mA}	mA value for the On (100%) position
P11.4	Position output	Calib. 20 mA 1	-10%...+10%	Calibrating the output position during the setting of this parameter will output a 20 mA (100%) signal. Use this parameter to calibrate accurately the 20 mA output signal (e.g., if you measure 19.8 mA at the output, just add 1% (0.2 mA... 1% of 20 mA) to the displayed value).
P11.5	Analog output	Function 2	see Function 1	
P11.6	Analog output	Begin 2 (at 0%)	see Begin 1	
P11.7	Analog output	End 2 (at 100%)	see End 1	
P11.8	Analog output	Calib. 20 mA 2	see Calib. 20 mA 1	

7.11 Parameter group: Step mode

Step mode operation can be used to extend the operating time in certain ranges or for the whole travel; it is available in local, remote and emergency mode.

Step mode operation can be activated individually for the directions OPEN and CLOSED.

Cycle start, cycle end, cycle duration and interval time can be set separately for both directions (see Bild 62, page 52).

	Menu item	Sub-menu item	poss. setting	Notes / comments
P12.1	Step mode function	Mode	0: disabled	Step mode operation is disabled
			1: enabled	Step mode operation is enabled in LOCAL, REMOTE and EMERGENCY operation
			2: Local only	Step mode mode is only enabled in LOCAL mode
			3: Remote only	Step mode mode is only enabled in REMOTE mode
			4: Local + Remote only	Step mode mode is enabled in REMOTE and LOCAL mode
P12.2	Step mode function	Start Open	0...100%	In OPEN direction, position in % from which the step mode operation should start.
P12.3	Step mode function	End Open	0...100%	In OPEN direction, position in % of which the step mode operation should end.
P12.4	Step mode function	Runtime Open	0.1...60	Runtime in OPEN direction
P12.5	Step mode function	Pause time Open	0.2...60	Pause time in OPEN direction

continued on next page

continued from previous page

	Menu item	Sub-menu item	poss. setting	Notes / comments
P12.6	Step mode function	Start Closed	0...100%	In CLOSED direction, position in % from which the step mode operation should start.
P12.7	Step mode function	End Closed	0...100%	In CLOSED direction, position in % of which the step mode operation should end.
P12.8	Step mode function	Run time Closed	0.1...60	Runtime in Closed direction
P12.9	Step mode function	Pause time	0.2...60	Pause time in Closed direction
P12.10	Step mode function	Timebase	0: Seconds	Time basis for run and pause times
			1: Minutes	
P12.11	Step mode function	Speed adaption	0:	Speed adaption not activated. Normal step mode function.
			1:	Speed adaption is activated. The speed is reduced according to the runtime and pause time in the step mode range. (Example: Running time 1 sec and pause time 1 sec results in half the speed). If the minimum speed is undershot, the actuator clocks in the converted ratio with the minimum speed. The speed adjustment is only applicable to actuators of the type CM and AB CSC.



Bild 62

NOTE: It is important to ensure that the mode of operation is not exceeded!
The running info on the actuator (see section 6.2.2, page 34) only flashes while the drive is running, i.e. during the break, no flash!

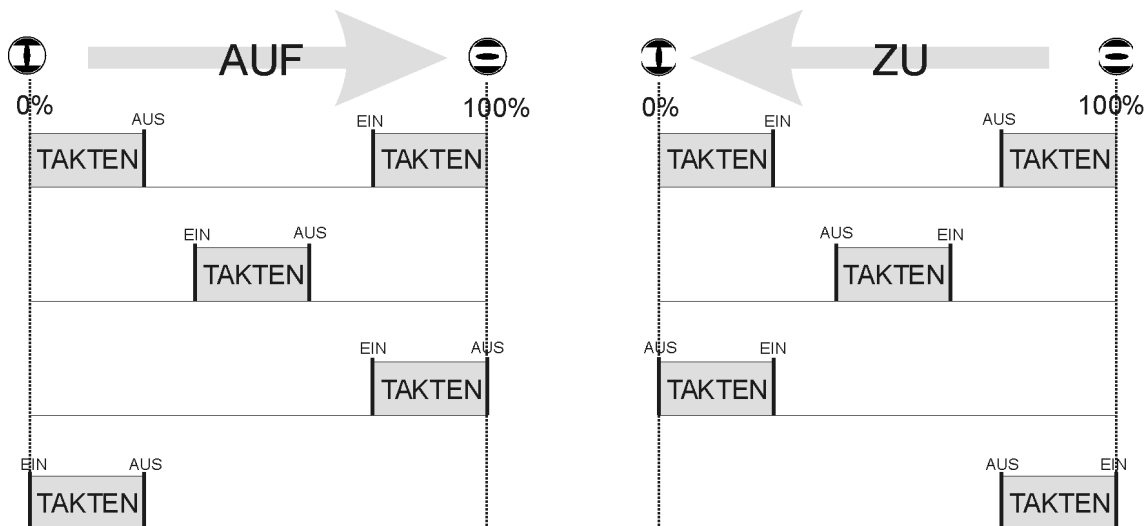

7.12 Parameter group: Positioner (optional)

The positioner SR option is used to control the electric actuator by means of a set point input 0/4...20 mA signal. The SR helps control the position of the actuator, i.e. the positioner ensures that the actual value and thus the position of the actuator matches the desired set point.

	Menu item	Sub-menu item	poss. setting	Notes / comments
P13.1	Positioner	Function	off	Positioner disabled
			1: Position	mA input for the position setpoint
			2: Pos. valvechar.	mA input for the position setpoint, taking into account the valve characteristic
P13.2	Positioner	Begin (at 0%)	0 ... 20.5 mA {4.0 mA}	mA value of the setpoint for the CLOSED (0%) position
P13.3	Positioner	End (at 100%)	0 ... 20.5 mA {20.0 mA}	mA value of the setpoint for the OPEN (100%) position
P13.4	Positioner	Dead band	0.1 ... 10.0% {1.0%}	Tolerance range for the control deviation (set point position – actual position) where no adjustment occurs. The deadband should not be set too low to prevent actuator oscillation.
P13.5	Positioner	Gain	1 ... 100% {100%}	The gain (gradient) affects the positioning close to the target position. The smaller the gain selected (e.g. 20%), the earlier the actuator starts reducing its speed in case of speed variable actuators on approaching the target position. In case of actuators with fixed speed (reversing starters), the speed reduction is done by pulsing (also see params P13.9 and P13.10). This leads to better positioning (smaller reachable deadband). A 100% setting disables this gradient.
P13.6	Positioner	Live zero detect.	Ignore	The setpoint monitoring (monitoring the setpoint to below approximately 2 mA = loss of signal) is disabled.
			1: Stop	Actuator stops on signal failure.
			2: Open	On signal failure, actuator moves the OPEN position.
			3: Close	Actuator moves on signal failure to the CLOSED position.
			4: Emerg.pos.	On signal failure, the actuator moves the defined emergency position (see parameter P13.7).
			5: Emerg. PID	reserved for future use
P13.7	Positioner	Emergency pos.	0 ... 100% {50,0%}	Determination of the emergency position (Can also be set in the menu P8.5)
P13.8	Positioner	Calib. setpoint	-10% ... +10%	Calibration value for the mA setpoint. Calibration process: By applying 20 mA on the setpoint input, this parameter is corrected until the readout matches 20 mA.
P13.9	Positioner	Min. impulse	{0,2 s}	Variable speed actuators (Actusmart CM and Smartcon CSC FU): Without function Fixed speed actuators (Smartcon CSC): Minimum activation time of the reversing contactors. For very small activation times (<0.3 ... 0.5 s), the motor will be switched off during start-up process, which significantly increases mechanical wear on reversing contactors. With frequent periods of very small activation times (restless loop, small dead zone, clocking near to the target value), we therefore recommend electronic reversing contactors.

continued on next page

continued from previous page

	Menu item	Sub-menu item	poss. setting	Notes / comments
P13.10	Positioner	Period	{2.0 s}	Variable speed actuators (Actusmart CM and Smartcon CSC FU): Without function Fixed speed actuators (Smartcon CSC): This parameter is only relevant in Step mode when approaching the target position (parameter gain smaller than 100%) and determines the period of a run / pause cycle.
P13.11	Positioner	Begin pos. (a0)	0.0...25.0% {2.0%}	Smallest controllable position other than the end position CLOSED. The range 0%...a0 will be just passed through. Use the parameter a0 to define the beginning of the allowable control range of the valve (e.g., blind spot for ball segment valves, etc.).
P13.12	Positioner	End pos. (e0)	75.0...100.0% {98.0%}	Largest controllable position other than the end position OPEN. The area e0...100% is just passed through. Use the parameter e0 to define the end of the allowable control range of the valve.
P13.13	Positioner	Begin setp. (a1)	0.0...25.0% {2.0%}	Below this value, the end position CLOSED is controlled. In the range 0%...a1 cannot be controlled (end position tolerance). The initial setpoint a1 is associated with a small hysteresis (1/4 of the deadband).
P13.14	Positioner	End setp. (e1)	75.0...100.0% {98.0%}	Above this value, the end position OPEN is controlled. The range e1...100% cannot be controlled (end position tolerance). The final setpoint e1 is associated with a small hysteresis (1/4 of the deadband).
P13.15	Positioner	Calib.setpoint offset	-10%...+10%	Calibration of zero for the input setpoint. 1% = 0.2 mA



Bild 63: Assigning the position to the setpoint

7.13 Parameter group: PID controller (optional)

The optional PID controller is used for controlling an external actual value (process variable) to a setpoint using 0/4...20 mA signal by readjusting the actuator.

	Menu item	Sub-menu item	poss. setting	Notes / comments
P14.1	PID-controller	Function	0: disabled	PID controller disabled
			1: Position	The output of the PID controller corresponds to the position setpoint of the actuator. The positioning (tracking of the actual position to the setpoint) is done by the positioner (see section 7.12).
			2: Speed	The output of the PID controller corresponds to the speed of the actuator (speed mode is only possible for Actusmart CM and Smartcon CSC FU!). There is no adjustment with the positioner. ⁵⁾
			3: Speed	The output of the PID controller corresponds to the change of the position setpoint (speed) of the actuator. The positioning (tracking of the actual position to the setpoint) is done by the positioner (see section 7.12). Hence a control mode similar to the Speed mode (see Setting 2, above) is possible also for actuators with constant speed. ⁶⁾
P14.2	PID-controller	External Setpoint	0: fixed	The PID controller uses an internal, fixed setpoint (see param P14.3).
			1: external	The PID controller uses the external setpoint. Adjust this setpoint with the params P13.2 and P13.3 (see section 7.12).
P14.3	PID-controller	Fixed setpoint	0...100%	Specification of the internal fixed setpoint
P14.4	PID-controller	Start (at 0%)	0...20.5 mA	mA value at 0% of the external actual value
P14.5	PID-controller	End (at 100%)	0...20.5 mA	mA value at 100% of the external actual value
P14.6	PID-controller	Gain (P)	-50.0...+50.0	Gain (proportional value) of the PID-controller. A negative value reverses the effective direction of the PID-controller, e.g.: Positive gain: The actuator opens when the desired value is greater than the external actual value. Negative gain: The actuator closes when the desired value is greater than the external actual value.
P14.7	PID-controller	Reset time (I)	0...100.0 s	The shorter the reset time (integral time, integral value), the stronger the effect of the integral component of the PID-controller. Values below 1.0 will disable the integral component.
P14.8	PID-controller	Lead time (D)	0...100.0 s	The larger the lead time (differential/derivative value), the stronger the effect of the dervative component of the PID-controller. To reduce the influence of noise, a first-order lag element with 1 sec time constant is added (DT ₁) .

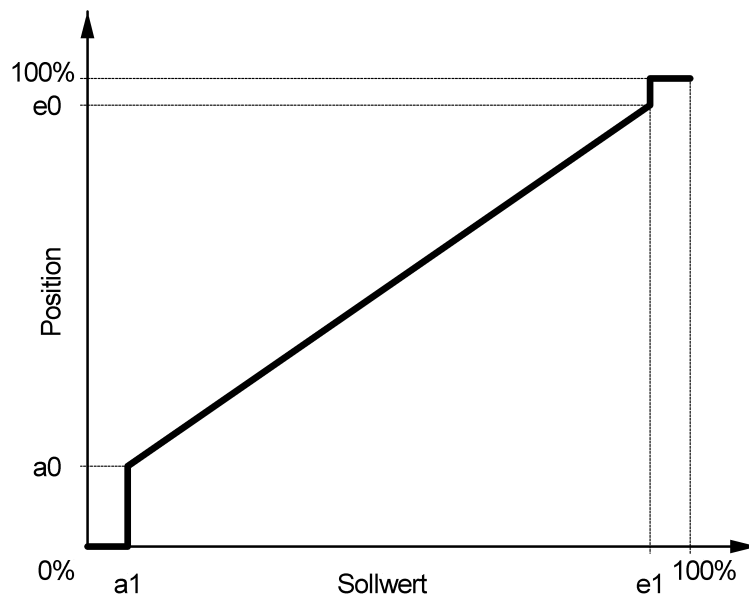
continued on next page

⁵⁾from firmware 1.338

⁶⁾from firmware 1.338

continued from previous page

	Menu item	Sub-menu item	poss. setting	Notes / comments
P14.9	PID-controller	Offset	-200...+200%	The offset value will be added to the output value of the PID controller.
P14.12	PID-controller	Live zero detect.	0: Ignore	The monitoring of the external actual value is disabled.
			1: Stop	Actuator stops on signal failure of external. actual value
			2: Open	On signal failure of external actual values, actuator moves to the OPEN position.
			3: Closed	On signal failure of external actual values, actuator moves to the CLOSED position.
			4: Emergency position	On signal failure of external actual values, actuator moves to the EMERGENCY position (see param P13.7).
			5: Emergency PID	reserved for future use
P14.13	PID-controller	Calibration of ext. actual value	-10.0...+10.0%	Calibration process: By applying 20 mA to the external actual value input, this parameter is corrected until the readout matches 20 mA.
P14.14	PID-controller	Process begin	- 32768...+32767	Mantissa of the real process variable (begin of external actual value)
P14.15	PID-controller	Process end	- 32768...+32767	Mantissa of the real process variable (end of external actual value)
P14.16	PID-controller	Process comma shift	-3...+3	Position of the comma for process begin/end (P14.14, P14.15), e.g.: mantissa = 200, comma shift = -2/2, process value = 2.00/20000
P14.17	PID-controller	Process unit	—	Unit of the real process variable
P14.18	PID-controller	Dead band	0.1...10.0% {1.0%}	Tolerance range for the control deviation (set point – external actual value) where no adjustment occurs. ⁷⁾

7.14 Parameter group: Bus systems (optional)

The manuals for the Bus systems are available in the download area on our homepage www.schiebel-actuators.com under the tab **Quality & Service**.

7.15 Parameter group: Characteristic curves (optional)

With this option, customers can enable travel-dependent torque, speed and valve characteristic curves.

7.15.1 Torque characteristic

With this characteristic curve, torque limits already set under menu item **P2-torque** (see section 7.2, page 42) can be further **reduced** depending on travel. Characteristics can be configured via the SMARTTOOL software (see Bild 64, page 57).



⁷⁾from firmware 1.340



Bild 64: Torque characteristic

	Menu item	Sub-menu item	poss. setting	Notes / comments
P17.1	Characteristic	Torque Open	0: Off	The torque characteristic curve is disabled for the OPEN direction.
			1: On	The torque characteristic curve is enabled for the OPEN direction.
			2: Local + Remote only	The torque characteristic curve is enabled for the OPEN direction only in LOCAL and REMOTE mode (while disabled in the EMERGENCY mode).
P17.2	Characteristic	Torque Closed	0: Off	The torque characteristic curve is disabled for the CLOSED direction.
			1: On	The torque characteristic curve is enabled for the CLOSED direction.
			2: Local + Remote only	The torque characteristic curve is enabled for the CLOSED direction only in LOCAL and REMOTE mode (while disabled in the EMERGENCY mode).

7.15.2 Speed characteristic

With this characteristic curve, speed limits already set under menu item **P4-speed** (see section 7.3, page 43) can be further **reduced** depending on travel. Characteristics can be configured via the SMARTTOOL software (see Bild 65, page 58).

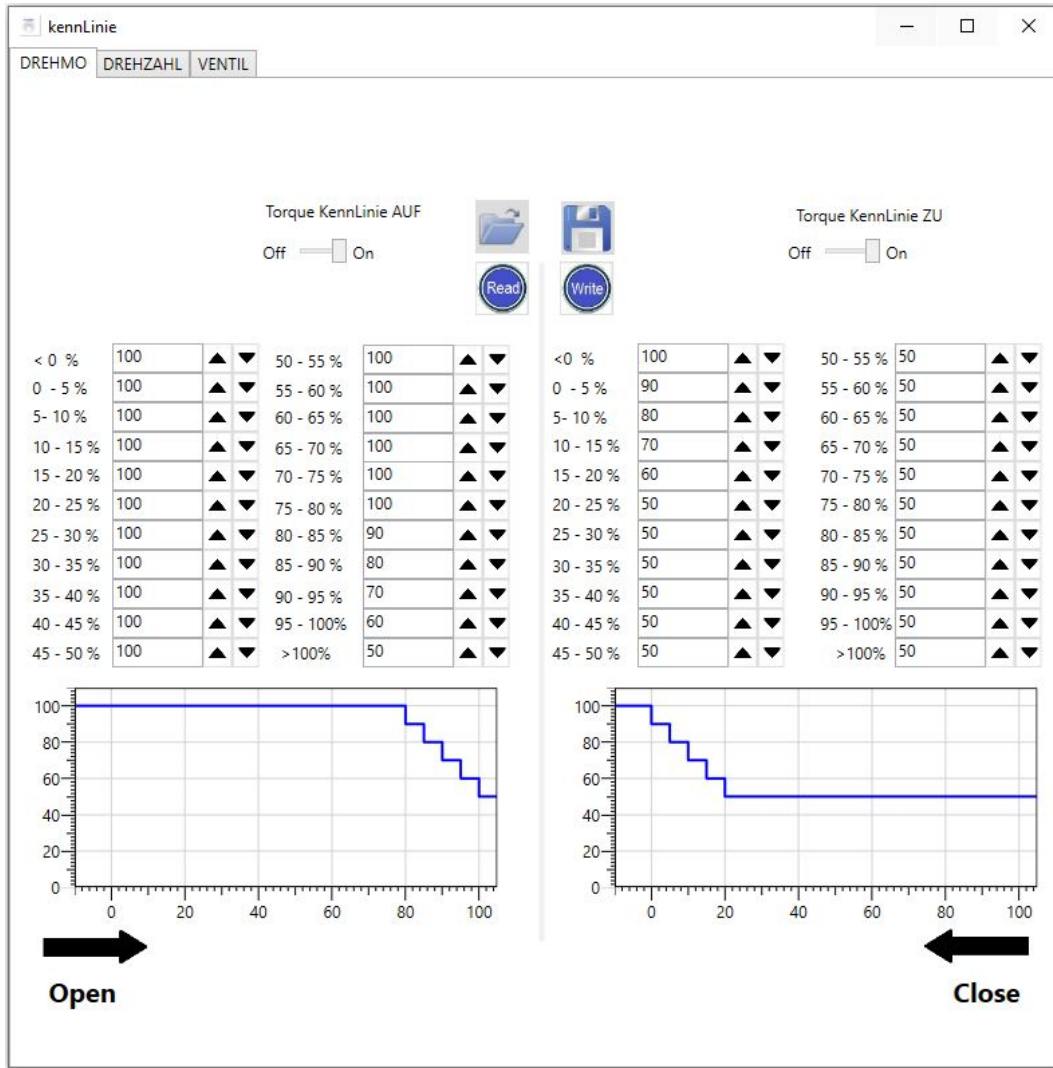

Bild 65: Speed characteristic

	Menu item	Sub-menu item	poss. setting	Notes / comments
P17.3	Characteristic	Speed Open	0: Off	The speed characteristic curve is disabled for the OPEN direction.
			1: On	The speed characteristic curve is enabled for the OPEN direction.
P17.4	Characteristic	Speed Closed	0: Off	The speed characteristic curve is disabled for the CLOSED direction.
			1: On	The speed characteristic curve is enabled for the CLOSED direction.

7.15.3 Valve characteristic

With this characteristic curve the mapping between the actuator position and the setpoint of the valve can be adjusted. Hence it is possible to compensate and linearize the general nonlinear characteristic curves of valves. Characteristics can be configured via the SMARTTOOL software (see Bild 66, page 59).

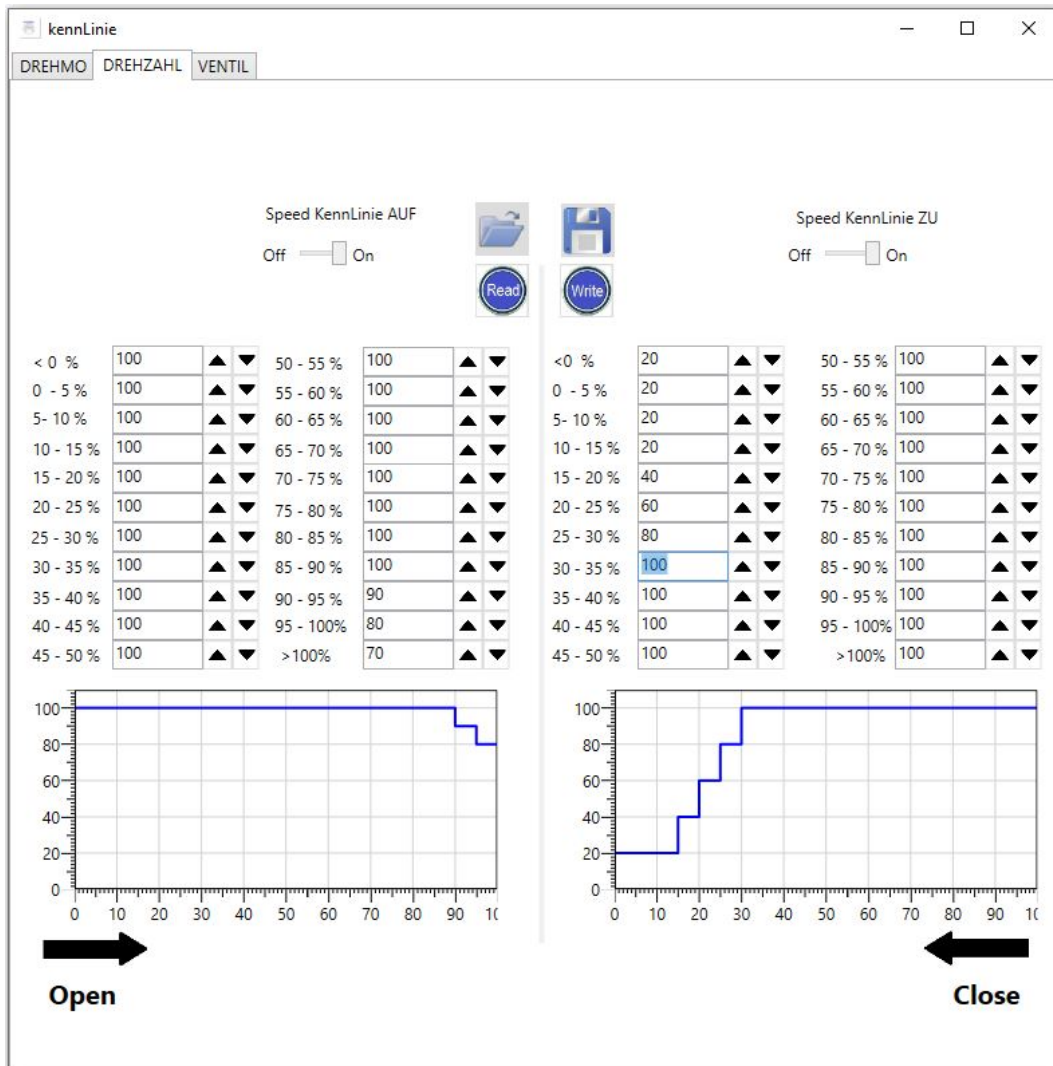



Bild 66: Valve characteristic

	Menu item	Sub-menu item	poss. setting	Notes / comments
P17.5	Characteristic	Valve	0: Off	The valve characteristic curve is disabled.
			1: user defined	The valve characteristic curve is enabled as configured in the SMARTTOOL.

7.16 Parameter group: Identification (optional)

This option allows entering further custom-identification parameters.

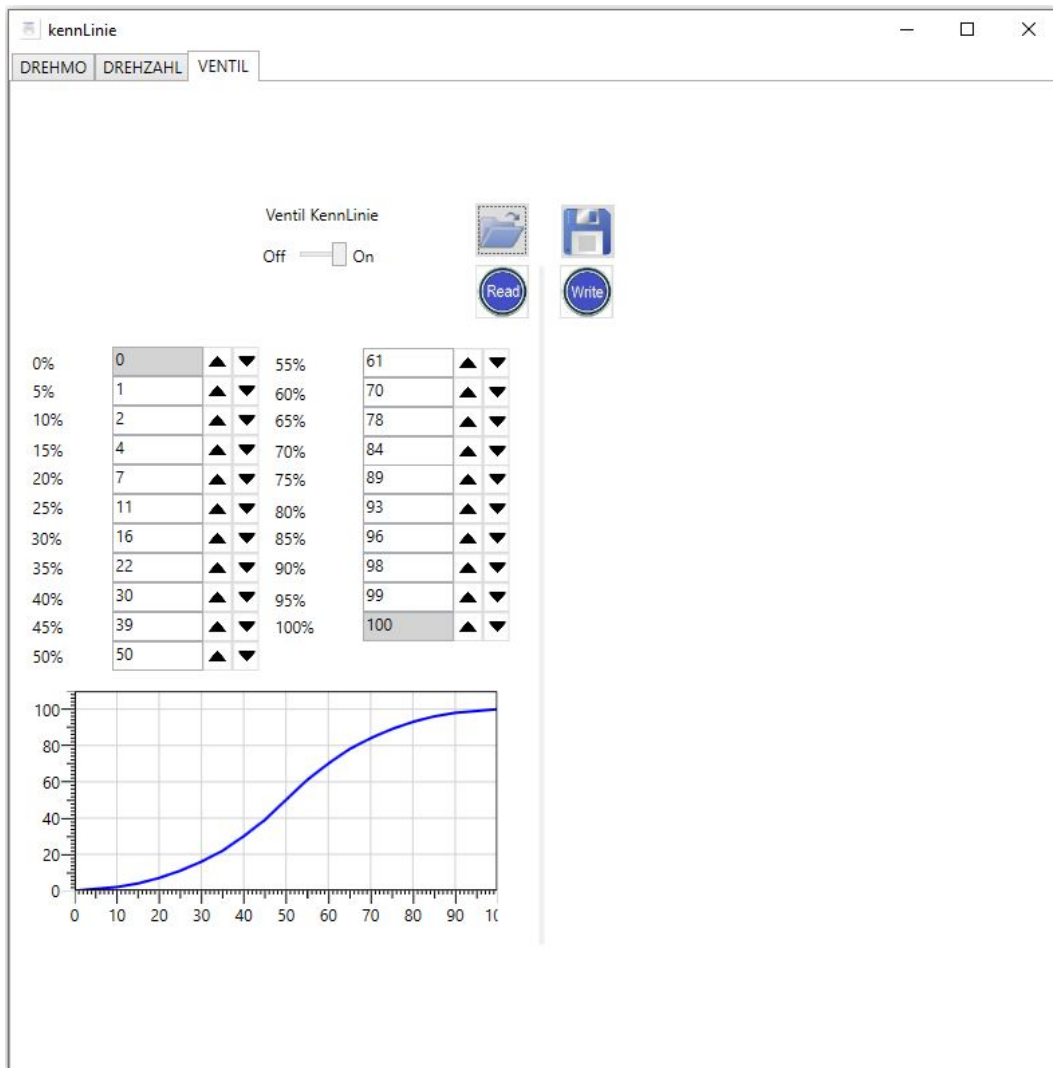
	Menu item	Sub-menu item	poss. setting	Notes / comments
P18.1	Identification	PPS number	15 digits	Used to enter a PPS number. This is displayed in the bottom line. CAUTION: Param P20.5 must be set to 0.

7.17 Parameter group: System parameters (locked)

Used for actuator configuration and not available for customers.

7.18 Parameter group: Miscellaneous

	Menu item	Sub-menu item	poss. setting	Notes / comment
P20.1	Miscellaneous	Language	0: German	Defines the menu language
			1: English	
			2: Russian	
			3: Czech	
			4: Spanish	
			5: French	
			6: Italian	
			7: Danish	
			8: Hungarian	
			9: Turkish	
			10: Greek	
			11: Polish	
			12: Serbian	
13: Croatian				
P20.2	Miscellaneous	Smartcode		Enables additional features by entering a Smartcode
P20.3	Miscellaneous	Restore para	0:	no action
			1: Custpara -	By saving this setting, all parameters except the end positions are reset to the customer parameters.
			2: Custpara +	By saving this setting, all parameters are reset to the customer parameters.
			3: Backuppara -	By saving this setting, all parameters except the end positions are reset to the factory settings.
			4: Backuppara +	By saving this setting, all parameters are reset to the factory settings.
P20.4	Miscellaneous	Backup para	0:	no action
			1: Custpara	By saving this setting, the currently set parameters are adopted as customer parameters.
P20.5	Miscellaneous	Info line	0...31	The fourth line of the display shows various diagnostic values.
P20.6	Miscellaneous	Infrared	0: Off	The infrared connection is disabled.
			1: Infrarot	The infrared connection is active for about 3 minutes unless communication is detected.
			2: Bluetooth	The Bluetooth connection is active for about 3 minutes unless communication is detected.
			3: Infrarot+	The infrared connection is activated.
			4: Bluetooth+	The Bluetooth connection is activated.
P20.7	Miscellaneous	Menu style	0...2	different menu styles
P20.11	Miscellaneous	Daylight saving time	0: off	Normal time is activated
			1: on	Daylight saving time is activated.
			2: auto	The actuator switches automatically between Daylight saving time and Normal time.

8 Status area

The status area presents current process and diagnostic data. In this area, data is read-only. To access the status area, move the control switch in the direction where the selector switch should be in the neutral position or in the remote position.

The status area is divided into 2 sub-areas:

- Status
- History

8.1 Status

8.1.1 Status – binary outputs

Display of binary outputs: The display shows output control as opposed to output status, i.e. the supply of the binary outputs is ignored. A switched output is represented by 1.

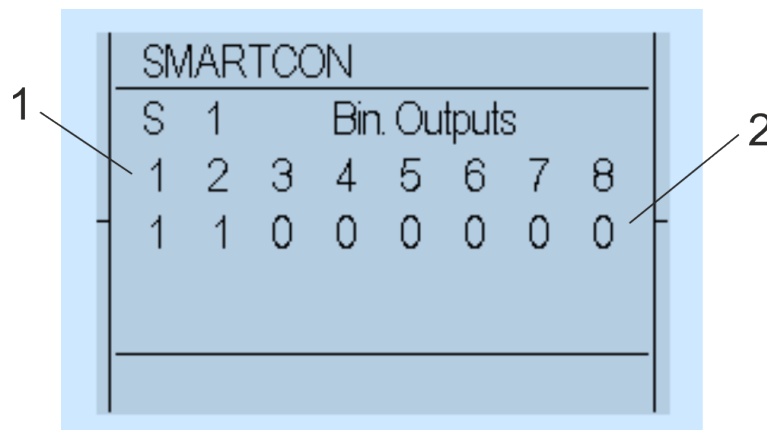

SMARTCON	
S 1	Bin. Outputs
1 2 3 4 5 6 7 8	
1 1 0 0 0 0 0 0	

Bild 67: 1... Output Number, 2... Signal (0 = LOW; 1 = HIGH)

8.1.2 Status – binary inputs

Display of binary inputs: A set input is represented by 1.

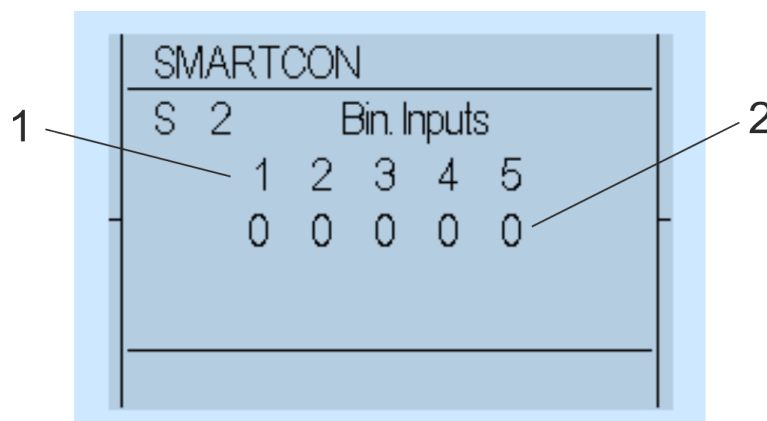

SMARTCON	
S 2	Bin. Inputs
1 2 3 4 5	
0 0 0 0 0	

Bild 68: 1... Input number, 2... Signal (0 = LOW; 1 = HIGH)

8.1.3 Status – analog values

Display of analogue values: Input 1 (In1) is used by the positioner as the setpoint; Input 2 (In2) serves as an external value for the optional PID controller. In the analogue output (out), only the control signal is shown, regardless of whether the output current actually flows or not (interruption of the current loop).



Bild 69: 1... Input 1, 2... Input 2, 3... Output, 4... All values in mA

8.1.4 Status – absolute values

This status displays the absolute position of the actuator.

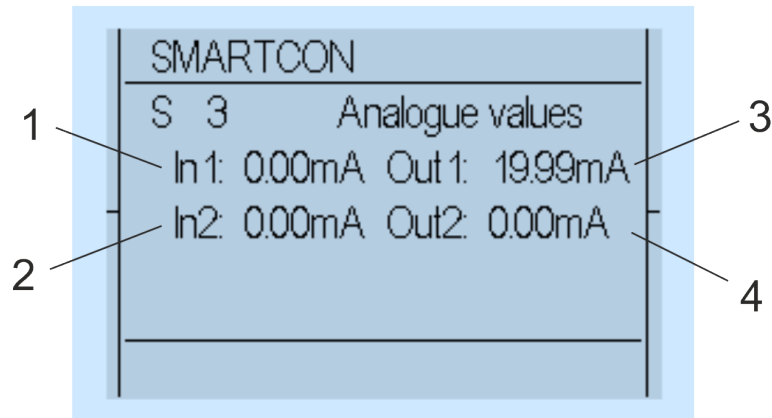

Bild 70: 1... Absolute value of the position unit, 2... Relative value of the position unit 3 and 4 ... Absolute and relative value for the torque unit (calibrated in factory)

8.1.5 Status – firmware

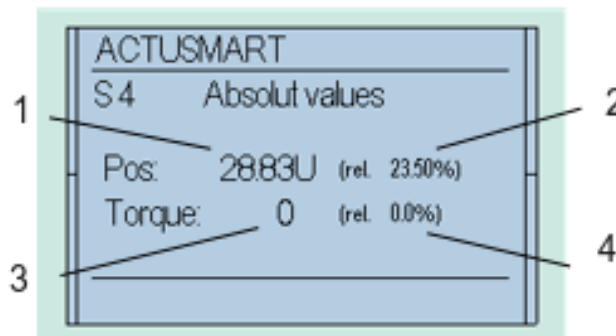

Bild 71: 1... Firmware, 2... Firmware date

8.1.6 Status – serial number

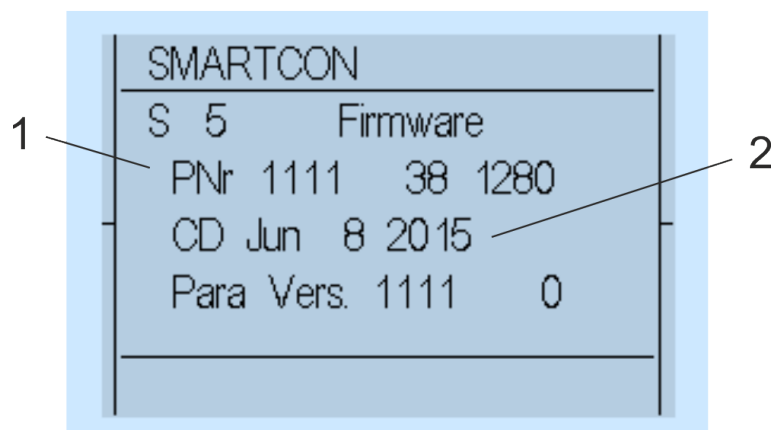

Bild 72: 1... Serial number of the control unit, 2... Serial number of the actuator, 3... Serial number of electronics

8.1.7 Status – meter readings

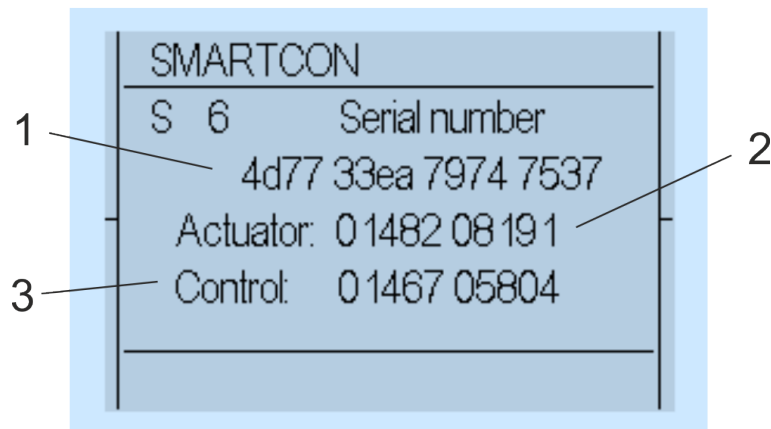

Bild 73: 1... Power-on cycles, 2... Operating hours, 3... Engine duration

8.2 History

History shows the last 20 history entries. In addition to the plain text entry, the time since the last history entry is also provided.

Please note that the actuator can only calculate time if energised. For error analysis, please refer to section 12, page 65.

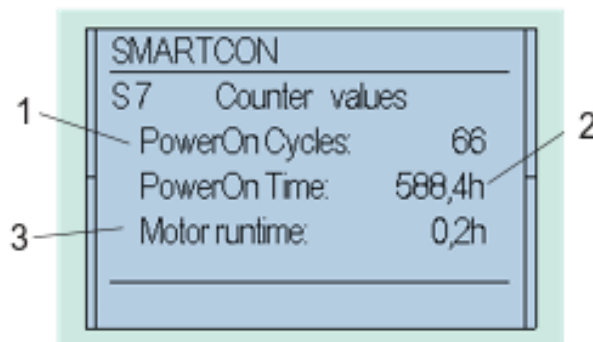
9 Infrared connection

For easier communication and better visualization of the menu options, the unit provides an infrared port for connection to a PC.

The required hardware (connection cable to the PC's RS-232 or USB connectors) and the corresponding software are available as options.

The SMARTTOOL software, in addition to communication with the actuator, allows the management of multiple actuators to transfer the configuration to different actuators.

This approach can greatly simplify operation.

Please refer to the SMARTTOOL software operating instructions manual for further information.

During operation, it must be ensured that the IR interface surface is protected from strong disturbances which may otherwise compromise the communication.

Before mounting the infrared adapter, clean the surface of the infrared interface with a damp cloth.

When the infrared interface is enabled, it is indicated by LED L5 (see section 6.2.2, Bild 74, page 34). The infrared interface can be enabled in the menu item P20.6.



Bild 74: 1... Infrared connection

10 Bluetooth connection

In addition to the infrared interface, it is also possible to configure the Control System using a Bluetooth interface.

Software required for Android equipment is available as an option.

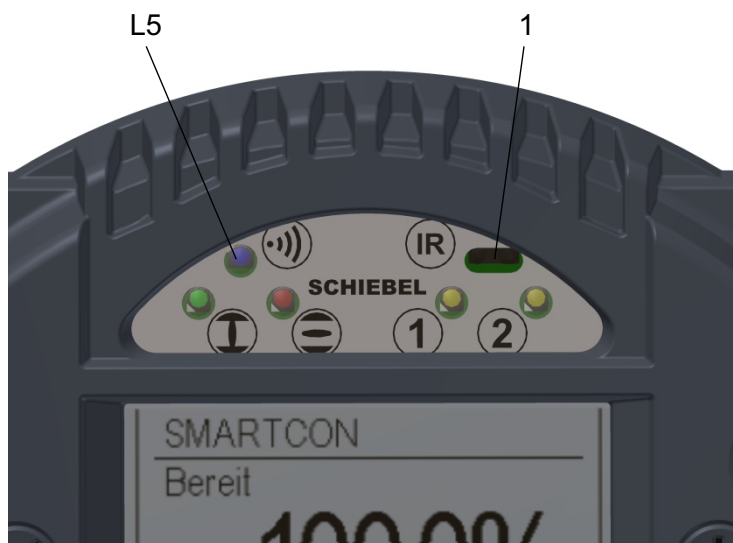
In addition to communication with the actuator, the Android software also enables management of multiple actuators, allowing easy transfer of parameter sets to various actuators.

This approach can significantly simplify commissioning.

When the Bluetooth interface is enabled, this is indicated by LED L5 (see Bild 74 resp. section 6.2.2, page 34). The Bluetooth interface can be enabled in menu item P20.6.

11 Maintenance

Maintenance work on open actuators may only be conducted if these are de-energized. Reconnection during maintenance is strictly prohibited.

Work on the electrical system or equipment must be carried out only in accordance with electrical regulations by a qualified electrician himself or by specially instructed personnel under the control and supervision of a qualified electrician.



For explosion-proof actuators, it is necessary before opening the cover to wait a certain time after switching off, see explosion protection sticker (Picture 75). Following times are specified for the actuators.



- CM03: 5 min
- CM06: 10 min



Bild 75: 1... Explosion protection sticker

Actuators are ready for use after installation. By default, the actuator is delivered filled with oil.
On-going monitoring:

- Beware of increased running noise. During long downtime periods, operate the actuator at least every 3 months.
- For actuators with output types A, B and C according to DIN 3210-A, B1, B2 and C according to DIN ISO 5210, re-lubricate at least every 6 months on existing grease fittings (see section 15.3, page 69).

Actuators are designed for installation in any position (see section 2.5, page 22). Therefore, the main body is not equipped with a level indication or a drain plug.

The replacement of the lubricant from the main body must be performed via the handwheel.

Every approx. 10,000 to 20,000 hours (about 5 years, see section 15, page 68), depending on the workload, you must:

- change oil, and
- replace seals.

Check all roller bearings and the worm-wheel assembly and replace if necessary.

Check our lubricants table for recommended oils and greases (see section 15, page 68).

Check the cable glands at regular intervals (annually) for tightness of the cables and retighten if necessary.



If the visual inspection (eg. dust or water penetration) indicates that the effectiveness of the sealing elements of the cable entry has suffered damage or aging, such elements have to be replaced preferably by using the original spare parts from the manufacturer of the equipment or through cable entries of comparable quality as well as the same ex- or IP protection class.

If screws need to be replaced, it is preferable to use original replacement parts. The tensile strength of the screws must be at least 400 N/mm² !

12 Troubleshooting

Upon warning or error, the bottom line of the display will show the corresponding plain text description. This event will also be entered into the history (see section 8.2, page 63).

12.1 Error list

CAUTION: Each error has a unique error number. Each error also has its separate “OK” message in the history after the fault has gone.



Error	Description
#3: Mot. temp. warn. #19: Mot. temp. warn. OK	The motor temperature is in the critical range although the actuator remains fully functional.
#4: Mot. temp. trip. #20: Mot. temp. OK	Overtemp in motor, fault on Basis or BLDC, On Basis: loss of main power (3x400V) or cable break between CSC and motor; on BLDC: cable break between BLDC and motor.
#5: Phase sequ. error #6: Phase sequ. OK	Cause on Basis: Active phase sequence detection on single phase actuators, loss of main power while connected to external 24 VDC auxiliary voltage, or loss of phase L2.
#7: Ready	Written to the history after all errors are gone.
#8: Power On	Is written to the history after power on the actuator, even if there are some errors.
#9: Power supply error #21: Power supply OK	No power supply to the power electronics (when the controller is powered from the auxiliary power input). Defect of power electronics – please contact the manufacturer.
#11: Failsafe error #12: Failsafe OK	Communication error between Failsafe board and Logic, loss of external 24 V Failsafe Voltage, or overtemp. on Failsafe brake.
#13: Manual override #14: Manual override off	Manual override on Failsafe activate (visible in status S4), cable/switch broken.
#17: Travel error #18: Travel OK	The travel unit is outside the permitted range (potentiometer fault on Basis), cable broken, or multiturnsensor calibration lost on CM – please contact the manufacturer.
#22: Torque error #23: Torque OK	Potentiometer fault on Basis, or cable broken.
#24: Bus error #25: Bus OK	No communication with the optional bus system.
#26: Bus Watchdog #27: Bus Watchdog OK	Watchdog for bus communication has reacted.
#28: Undervoltage> Warning #29: Voltage OK	The input voltage is below the regular voltage range, but motor operation is still possible.
#32: Internal Comm.L> error #33 Internal Comm.L> OK	Communication error between Logik and Basis/BLDC, cable broken between boards, or board defect.
#34: Internal Comm.D> error #35: Internal Comm.D> OK	Communication error between Display and Logik, cable broken between boards, boards defect, or firmware update on Logik not properly done.
#36: Failsafe not ready #37: Failsafe ready	Failsafe voltage OK and Failsafe not initialized (LUS not tensioned).
#38: Battery low #39: Battery OK	Battery on Display board is empty, loss of time/date or counter values possible.
#44: Inverter error Para #45 Inverter OK Para	BLDC parameter error.
#46: Analog Input 1 Failure #47: Analog Input 1 OK	SRG active, Positioner live zero detection activated, no setpoint value recognized.
#48: Analog Input 2 Failure #49: Analog Input 2 OK	Ext. setpoint active, Ext. setpoint live zero detection activated, no Ext. setpoint value recognized

Error	Description
#56: Internal Comm.E> error #57: Internal Comm.E> OK	Communication error between Logik and Failsafe (external connection) – please contact the manufacturer.
#58: Undervoltage> Warning	The input voltage is too low. The motor is switched off, until the input voltage is in the regular voltage range.
#59: Undervoltage> Switchoff	The input voltage dropped below the lower threshold multiple times. The motor is turned off for 5 minutes. This error can be acknowledged by switching the selector switch to OFF or by turning the actuator off and on.
#60: Overvoltage> Warning	The input voltage is over the regular voltage range, but motor operation is still possible.

Errors in case of special types

Error	Description
#30: Oil level low #31: Oil level OK	Binary input on Basis board or switch faulty.
#40: Oil pressure low #41: Oil pressure OK	Analog input (4...20 mA) on Basis board faulty.
#42: Motor protection #43 Motor protection OK	Binary input on Basis board or switch faulty.

13 Fuses

The Logik board of the controller cover (see Bild 76, page 68) features two miniature fuses for the control lines.



Bild 76: FL1... fuse for auxiliary supply, FL2... fuse for the binary outputs

Fuses on the logic board

Fuse	Value	Manufacturer	No. of spare parts
FL1	1AT	Littelfuse 454 NANO ² Slo-Blo [®] slow	FUSE-F1
FL2	4AT	Littelfuse 454 NANO ² Slo-Blo [®] slow	FUSE-F2

The frequency inverter is protected by an input fuse and the explosion-proof version also has a thermal fuse (see section 2.7.3, page 23).

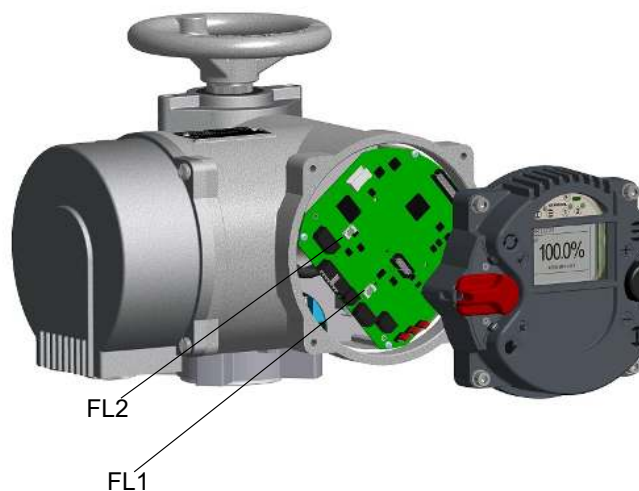

14 Spare parts

When ordering spare parts, please provide us with the serial number of the actuator (see section 2.2, page 21). Check the separate break-down image and separate list of spare parts.

15 Lubricant recommendation, lubricant requirements

Please note, that safety precautions such as the use of personal protective equipment (PPA) may have to be followed! Please consult the safety datasheet (in section 8) of the product in question.



15.1 Main body: -25 to +60°C

Operating oil: DIN 51 517-CLP-HC

i.e. fully synthetic high-performance gear oils based on poly-alpha-olefins (PAO)

Viscosity class:	320 ISO VG
Pourpoint:	< -39°C (according DIN ISO 3016)
Lubricant requirement CM03:	200... 250 ml
Lubricant requirement CM06:	300... 350 ml

15.2 Main body: -40 to +60°C

Operating oil: DIN 51 517-CLP-HC

i.e. fully synthetic high-performance gear oils based on poly-alpha-olefins (PAO)

Viscosity class:	68 ISO VG
Pourpoint:	< -54°C (according DIN ISO 3016)
Lubricant requirement CM03:	200... 250 ml
Lubricant requirement CM06:	300... 350 ml

15.3 Output type A and spindle drives (linear actuators) -40 to +60°C

Grease DIN 51825-K(P) R -40

i.e. water repellent complex grease on Al-soap base with high resistance to acids and alkalis

Penetration 0.1 mm:	310 -340
Dropping point:	about 260°C
NLGI No.:	1
acid-free, little or not water-reactive	

15.4 Basic lubricant service interval

Schiebel actuators must be serviced 10 years after delivery by SCHIEBEL Antriebstechnik GmbH, A-1230 Vienna. The functionality and durability of the lubricant is however contingent upon the operating conditions. Where applicable, reduction factors must be considered.



Operating condition (s)	Definition	Reduction factor (multiplier)
Duty time DT	(Total engine running time)	
Extremely high DT	over 1250 hours/year	0.5
High DT	over 500 hours/year	0.7
Extremely low DT	less than 0.5 hours/year	0.8
Ambient temperature	(permanent or long-term)	
Extremely changeable	between -10 and +50°C	0.5
Extremely high	above +50°C	0.7
Extremely low	below -25°C	0.9
Output speed	(on actuator main shaft)	
High speed	over 80 rpm	0.8
Utilisation	(relative to rated power)	
Very high	over 90%	0.8
High	between 80 and 90%	0.9

Application example:

Extremely low DT + extremely low ambient temperature + high speed + 87% utilization

*⇒ 0.8 * 0.9 * 0.8 * 0.9 = 0.51 reduction factor*

*Lubrication maintenance interval ⇒ 10 years * 0.51 = 5.1 years (62 months).*

CAUTION: This calculated maintenance interval does neither apply to the maintenance of output type A (threated bushing) units nor to the maintenance of linear and spindle drive units. These units must be periodically lubricated (at least every 6 months) via the grease nipples (see section 15.3)!



During maintenance of our actuators, remove and replace old grease with new one. **Mixing of different lubricant types is NOT permitted.**

Quantities needed for lubricant service are listed in section 15, page 68.

16 Training

CAUTION: If you experience problems during installation or upon adjustments on site, please contact SCHIEBEL, Vienna at +43 (1) 66 108 or via the Internet at www.schiebel-actuators.com to prevent any operational errors or damage to the actuators. Schiebel recommends engaging only qualified personnel for installation of Schiebel actuators. Upon special request of the client, SCHIEBEL can conduct training on the activities listed in this operating manual at the factory of SCHIEBEL.



17 Original Declaration of Incorporation of Partly Completed Machinery

According Machinery Directive 2006/42/EC (Annex II, sub. B)

The manufacturer, the company:

SCHIEBEL Antriebstechnik Gesellschaft m.b.H.
Josef-Benc-Gasse 4
A-1230 Vienna

hereby declares that for the partly completed machinery described below:

Electric actuators series:

CM	rCM	exCM	exrCM
----	-----	------	-------

the following basic requirements of the Machinery Directive (2006/42/EC) are applied and fulfilled:

Annex I,	articles	1.1.2, 1.1.3, 1.1.5; 1.2.1, 1.2.1, 1.2.2, 1.2.6; 1.3.1, 1.3.2, 1.3.7; 1.5.1; 1.6.3; 1.7.1, 1.7.3, 1.7.4
----------	----------	--

The following European harmonized standards have been applied:

EN 12100:2010		
EN ISO 5210:1996	EN ISO 5211:2001	DIN 3358:1982

The relevant technical documentation for partly completed machinery referred to in Annex VII, Part B has been prepared. The manufacturer commits to electronically submitting the documents for the incomplete machine to the competent national authority upon request.

For the preparation of the technical documents is authorized:

Head of mechanical Engineering
Schiebel Antriebstechnik Gesellschaft m.b.H.
Josef-Benc-Gasse 4
A-1230 Vienna

This partly completed machinery must not be put into service until the final machinery into which it is to be incorporated has been declared in conformity with the provisions of the Machinery Directive 2006/42/EC, where appropriate.

The electric actuators as partly completed machinery are in conformity with the relevant regulations of the EU directives:

Directive 2014/30/EU ("EMV-Directive")
Directive 2014/35/EU ("Low voltage directive")
Directive 2014/34/EU ("ATEX-Directive") for correspondingly marked devices

The corresponding separate EC Declarations of Conformity are valid.

Vienna,
(location)

13th March 2018
(date)



.....
(Klaus Schiebel, general manager)

18 Declaration of Conformity (EMV directive and Low voltage directive)

The producer:

SCHIEBEL Antriebstechnik Gesellschaft m.b.H.
Josef-Benc-Gasse 4
A-1230 Wien

herewith confirms that the equipment

electric actuators with integrated control unit model Actusmart and following types

- (r) CM03
- (r) CM03 FS
- (r) CM06
- (r) CM06 FS

meets the requirement of the EC directive:

2014/30/EU („EMV directive“)

and complies with the following harmonised standards in the version valid at signature date:

EN 61000-6-2:2005 EN 61000-6-4:2014

and are also consistent with the EC directive:

2014/35/EU („Low voltage directive“)

in consideration of the respective operating instructions, and the fulfilment of the Directive has been demonstrated by the following standards:

IEC 60204-1:2005 + A1:2008 EN 60529:1991 + A1:2000

Vienna,
(location)

14.2.2018
(date)



.....
(Klaus Schiebel, general manager)

19 Declaration of Conformity

(Ex directive, EMV directive and Low voltage directive)

The producer:

SCHIEBEL Antriebstechnik Gesellschaft m.b.H.
Josef-Benc-Gasse 4
A-1230 Wien

herewith confirms that the equipment

electric actuators with integrated control unit model Actusmart and following types

Type ex (r) CM03	⊗ II 2 G Ex db eb (mb) II C T4(T6) Gb	TÜV-A13ATEX0006X
Type ex (r) CM03 FS	⊗ II 2 G Ex db eb (mb) II C T4(T6) Gb	TÜV-A13ATEX0006X
Type ex (r) CM06	⊗ II 2 G Ex db eb (mb) II C T4(T6) Gb	TÜV-A13ATEX0006X
Type ex (r) CM06 FS	⊗ II 2 G Ex db eb (mb) II C T4(T6) Gb	TÜV-A13ATEX0006X

meets the requirement of the EC directive:

2014/34/EU

EC Directive for Operation of Equipment in Potentially Explosive Atmospheres

and complies with the following harmonised standards in the version valid at signature date:

EN 60079-0:2012	EN 60079-1:2014	EN 60079-7:2015
EN ISO 80079-36:2016	EN ISO 80079-37:2016	

For the above listed actuators, a type examination certificate TUV A13ATEX0006X, issued by TÜV Austria Services GMBH, is available.

TÜV Austria Services GmbH	A-1230 Wien	NB 0408: Type examination certification
FTZU	CZ-716 07 Ostrava Radvanice	NB 1026: Quality system FTZU03ATEXQ019

Furthermore, they are consistent with the EC directive

2014/30/EU („EMV directive“)

in consideration of the respective operating instructions, and the fulfilment of the Directive has been demonstrated by the following standards:

EN 61000-6-2:2005	EN 61000-6-4:2014
--------------------------	--------------------------

and are also consistent with the EC-directive:

2014/35/EU („Low voltage directive“)

in consideration of the respective operating instructions, and the fulfilment of the Directive has been demonstrated by the following standards:

IEC 60204-1:2005 + A1:2008	EN 60529:1991 + A1:2000
-----------------------------------	--------------------------------

Vienna,
(location)

14.2.2018
(date)

.....
(Klaus Schiebel, general manager)

20 Technical data



Bild 77: Control unit



Bild 78: Logik board

20.1 Binary outputs

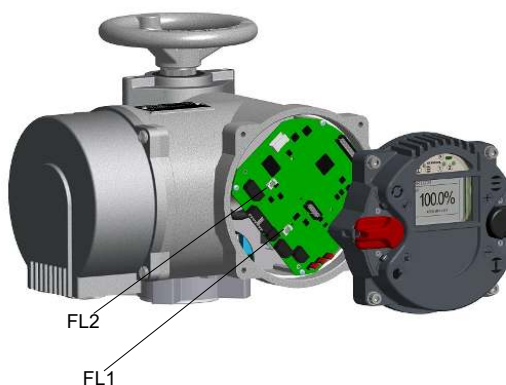
Count:	8
Power supply:	24 VDC nominal range: 11... 35 VDC (either from internal or external)
Max voltage drop at set output:	1 V
Output voltage at non-set output:	<1 V
Maximum current per output:	500 mA (short circuit proof)
Maximum permissible total current for all outputs:	4 A
Fuse (Fuse FL2, see Figure 78, page 74):	4 A slow (Littelfuse 454 NANO ² Slo-Blo [®])

Binary outputs with external supply are separated from other controllers via optocouplers.

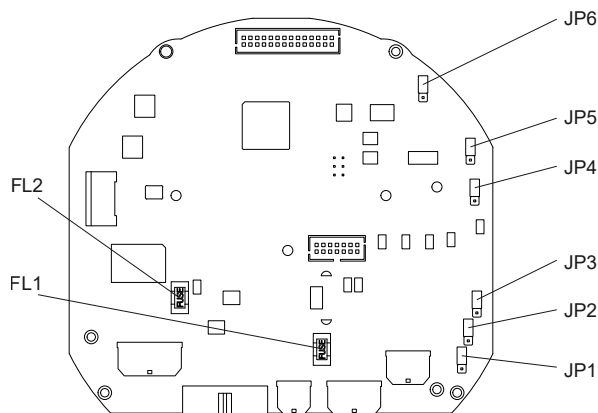
20.2 Binary inputs

Count:	5
Nominal voltage:	24 VDC towards common ground
Voltage for input set:	>10 V (8.5 V typ.)
Voltage for input not set:	<7 V (8.5 V typ.)
Maximum voltage:	30 VDC
Current consumption at 24 VDC:	10.5 mA typ.

Binary inputs are separated from other controllers via optocouplers.

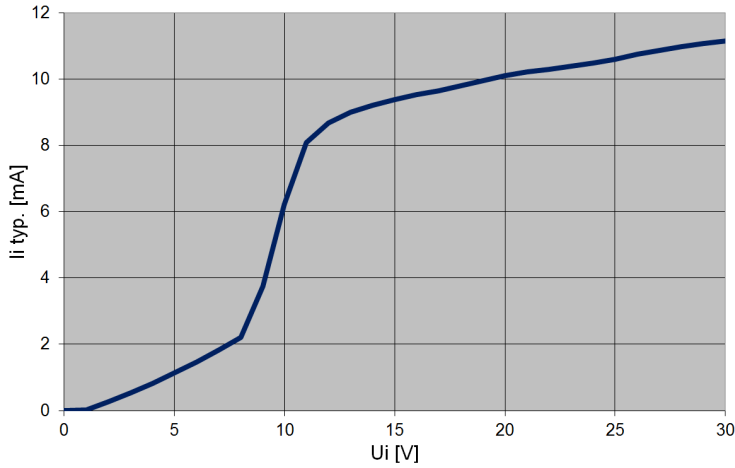

Ui ... Input voltage
li ... Input current

Bild 79: Binary inputs, input characteristic

Jumpers JP1 ... JP3 can be used to interconnect the binary inputs to groups with separate earths:



Bild 80: 5 inputs with same common



Bild 81: 2 separated groups of 2 inputs with same ground
Input IN3 is disabled.

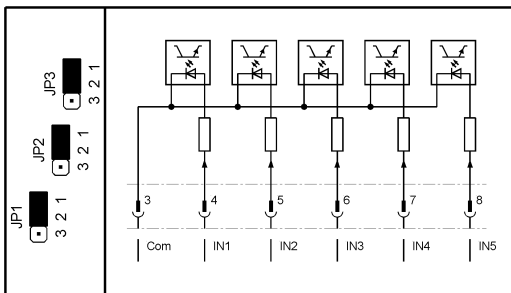

Bild 82: 3 separated inputs
Inputs IN2 and IN4 are disabled.

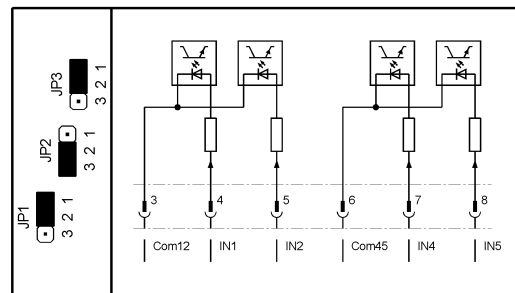

Bild 83: 3 inputs with same common and 1 separated input.
Input IN4 is disabled.

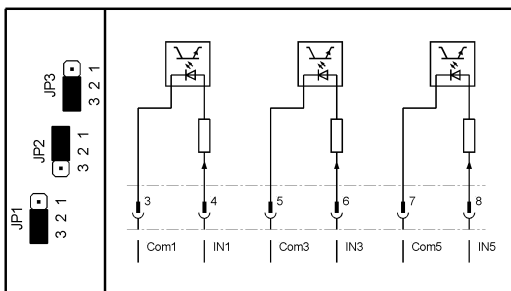

Bild 84: 1 separated input and 3 inputs with same common.
 Input IN2 is disabled.

Examples:

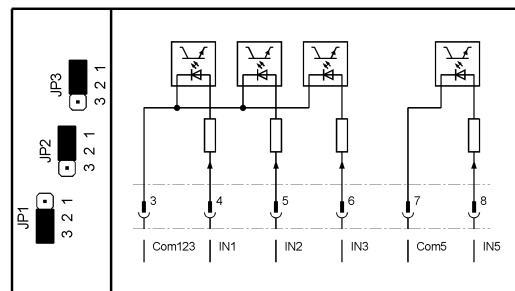

Bild 85: 5 inputs with common = using external 24V

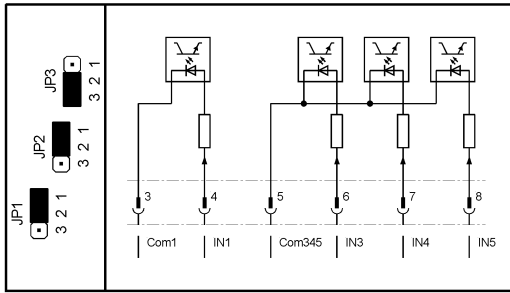

Bild 86: 5 inputs with common = using internal 24V
 (e.g. for dry contacts)

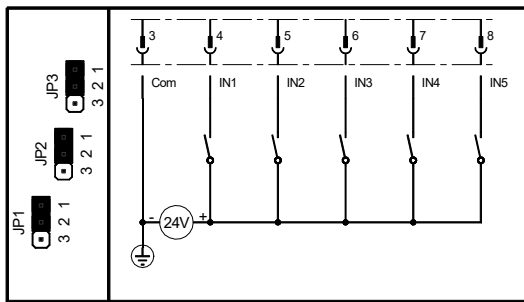

Bild 87: 3 separated inputs using 3 separated external 24V

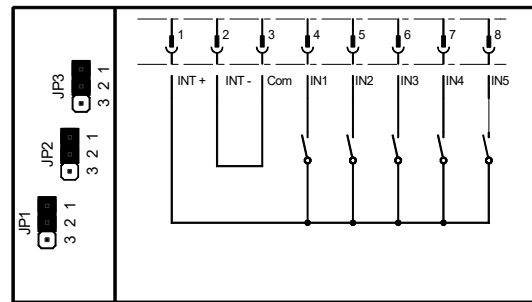

Bild 88: 3 separated inputs with common = "using external 24V

20.3 Analog inputs

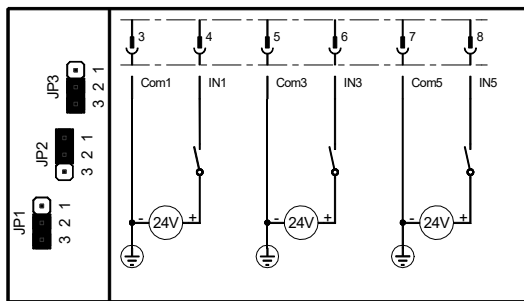
Input 1: setpoint value

- Current range:0...25 mA
- Resolution:14 bit
- Accuracy:0.5%
- Input resistance:60 Ω

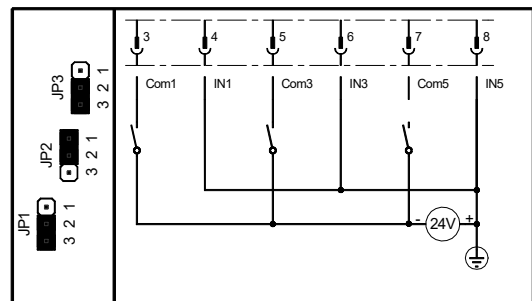
Analog input 1 is electrically isolated from the rest of the electronic system.

Input 2: External actual value (only in combination with PID controller)

- Current range:0...20.8 mA

Resolution: 12 bit
Accuracy: 0.5%
Input resistance: 120 Ω

Jumper JP6 can be used to switch analog input 2 from a passive input (default) to an input with internal 24 V power supply (for 4...20 mA, two-wire transmitters).



Bild 89: Passive input (default)



Bild 90: Input with internal supply (active input)

IMPORTANT: The analog input 2 is referenced to common of the electronic system and the auxiliary power supply (see section 20.5).

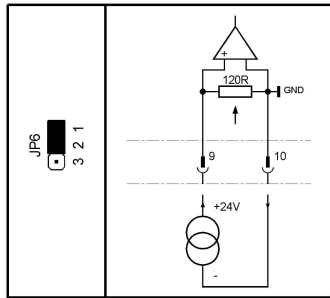

20.4 Analog output

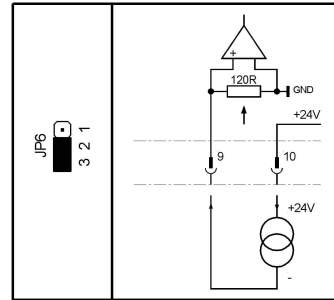
Current range: 0...20.8 mA
Resolution: 12 bit
Accuracy: 0.5%
Max load: 600 Ω

The analog output is galvanically isolated from the rest of the electronic system.

Jumper JP4 can be used to switch the analog output from an active power source (default) to a current sink, allowing the output to simulate a 4...20 mA, two-wire transmitter.



Bild 91: Current source



Bild 92: Current sink

Ground potential is the potential of the control unit and the auxiliary supply (see chapter 20.5).

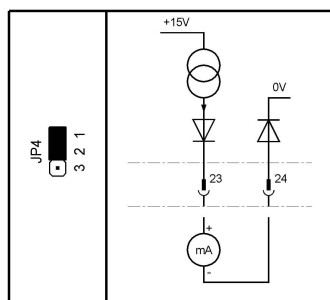
20.5 Auxiliary voltage input and output

Input voltage range (auxiliary voltage input): 20...30 VDC
Maximum current consumption (auxiliary voltage input): 500 mA
Maximum current consumption in power-save mode 120 mA
(auxiliary voltage input):
Output voltage (auxiliary voltage output): typ. 23 V
Maximum output current (auxiliary voltage output): 200 mA

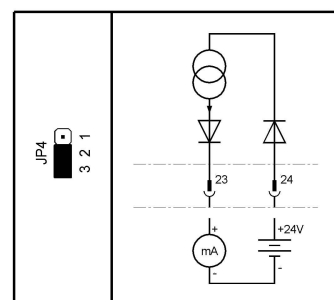
Resistance of common ground vs. earth: typ. 500 kΩ
 Resistance of common ground vs. earth (floating version): > 10 MΩ
 Capacitance of common ground vs. earth: typ. 100 nF
 Maximum allowed voltage of common ground vs. earth: max. 40 Vs
 Fuse (Fuse FL1, see picture 78, page 74): 1 A slow
 (Littelfuse 454 NANO² Slo-Blo[®])

Ground potential is the common ground of the controller and the analog inputs and outputs.
 The auxiliary voltage output can be set in menu P6.5 (see section 7.5, page 43).

The power-save mode is defined as follows:

- No power supply (the controller is powered exclusively through the 24 V auxiliary voltage input).
- The backlight of the LCD display switches off automatically.
- No additional hardware options included (Profibus Interface, DeviceNet interface, relay board, etc. ...).
- Binary outputs and the mA output are not enabled; when activating, the respective currents must be added to the total current consumption.

20.6 Connections

20.6.1 Connections for non explosion-proof version

Power/motor: Industrial plug with 6 pins
 Screw connection 16 A,
 max. 2.5 mm², AWG14
 Control signals: Industrial plug with 24 pins
 Screw connection
 16 A, max. 2.5 mm², AWG14

Optionally, contacts are available in crimp or cage clamp designs.

20.6.2 Connections for explosion-proof version

Power/motor: terminals with screw connection
 16 A, 0.5... 4 mm², AWG20... AWG12
 Control signals: terminals with screw connection
 4 A, 0.5... 2.5 mm², AWG20... AWG14

20.7 Miscellaneous

Ambient temperature:
 non explosion-proof version: -25 ... +60°C
 explosion-proof version: -20 ... +40°C (according EN 60079-0)
 ex version with extended temperature range: -40 ... +60°C
 Protection according to EN 60529: IP67
 Standard colour: RAL7024

21 Technical data CM03

The motor (brushless DC motor) is controlled via integrated power electronics, which also provide the supply voltage for the controller.

21.1 Standard version CM03

Output torque:	max. 32 Nm
Average permissible output torque:	max. 16 Nm
Setting range of tripping torque:	8 ... 32 Nm
Setting range of output speed:	2.5 ... 72.2 min ⁻¹
Travel range:	max. 100 revs
Reduction ratio handwheel:	2,5
Output resolution:	about 0.25°
Supply voltage range AC:	90 ... 240 Vrms +/-10%, 50/60 Hz
Supply voltage range DC:	100 ... 220 V +/-10%
Nominal current (16 Nm / 72,2 min ⁻¹):	1.47 A / 230 VAC
Idle power consumption:	12 W typ., 24 W max.
Weight:	11.5 daN

21.2 24 VDC version CM03

Output torque:	max. 32 Nm (output speed 5 min ⁻¹) max. 10 Nm (output speed 20 min ⁻¹)
Average permissible output torque:	max. 16 Nm
Setting range of tripping torque:	8 ... 32 Nm
Setting range of output speed:	2.5 ... 20 min ⁻¹
Supply voltage range:	24 VDC +/-10%
Nominal current (10Nm / 20U/min):	4.6 A
Idle power consumption:	6 W typ., 18 W max.
all other dates see output data - standard version	

21.3 400 V version CM03

Output torque:	max. 32 Nm
Average permissible output torque:	max. 16 Nm
Setting range of tripping torque:	8 ... 32 Nm
Setting range of output speed:	2.5 ... 72.2 min ⁻¹
Travel range:	max. 100 revs
Output resolution:	about 0.25°
Supply voltage range AC:	3 x 380 ... 480 VAC +/-10%, 50/60 Hz
Nominal current (16 Nm / 72.2 rpm):	0.46 A / 3 x 400 VAC
Weight:	11.5 daN

Idle power consumption is measured with an idle motor and is dependent on the existing hardware options.

22 Technical data CM06

The motor (brushless DC motor) is controlled via integrated power electronics, which also provide the supply voltage for the controller.

22.1 Standard version CM06

Output torque:	max. 64 Nm
Average permissible output torque:	max. 20 Nm
Setting range of tripping torque:	16 ... 64 Nm
Setting range of output speed:	2.5 ... 64 min ⁻¹
Travel range:	max. 100 revs / 300 revs
Reduction ratio handwheel:	2,5
Output resolution:	about 0.25° / 0.75°
Supply voltage range AC:	90 ... 240 Vrms +/-10%, 50/60 Hz

Supply voltage range DC: 100 ... 220 V +/-10%
Nominal current (20 Nm / 60min⁻¹): 2.17 A / 230 VAC
Idle power consumption: 12 W typ., 24 W max.
Weight: 15.5 daN

22.2 400V version CM06

Output torque: max. 64 Nm
Average permissible output torque: max. 20 Nm
Setting range of tripping torque: 16 ... 64 Nm
Setting range of output speed: 2.5 ... 64 min⁻¹
Travel range: max. 100 revs / 300 revs
Output resolution: about 0.25° / 0.75°
Supply voltage range AC: 3 x 380 ... 480 VAC +/-10%, 50/60 Hz
Nominal current (32 Nm / 60min⁻¹): 0.9 A / 3 x 400 VAC
Weight: 15.5 daN

Idle power consumption is measured with an idle motor and is dependent on the existing hardware options.

SCHIEBEL
www.schiebel-actuators.com

SCHIEBEL Antriebstechnik
Gesellschaft m.b.H.
Josef Benc Gasse 4
A 1230 Wien
Tel.: +43 1 66 108 - 0
Fax: +43 1 66 108 - 4
info@schiebel-actuators.com
www.schiebel-actuators.com