



Manufacturer

TLV CO., LTD.

Kakogawa, Japan

is approved by LRQA Ltd. to ISO 9001/14001



Instruction Manual

Clean Steam Direct-acting Pressure Reducing Valve DR8-3P / DR8-3EP DR8-6P / DR8-6EP

Copyright © 2020 by TLV CO., LTD.

All rights reserved

Contents

Introduction	1
Safety Considerations	2
Specifications	4
Acceptable Operating Range	4
Correct Usage of the DR8 Direct-acting Pressure Reducing Valve	5
Configuration	7
Installation	8
Adjustment	11
Maintenance	12
Disassembly	13
Reassembly	18
Troubleshooting	19
Product Warranty	21

Introduction

Thank you for purchasing the TLV DR8 clean steam direct-acting pressure reducing valve.

This product has been thoroughly inspected before being shipped from the factory. When the product is delivered, before doing anything else, check the specifications and external appearance to make sure nothing is out of the ordinary. Also be sure to read this manual carefully before use and follow the instructions to be sure of using the product properly.

The TLV DR8 clean steam direct-acting pressure reducing valve has been developed especially for the food, beverage and pharmaceutical industries. This product has an angle type structure with special polishing applied to internal parts to minimize areas for condensate to accumulate, and prevent contamination inside the product. Additionally this product has a structure that is easily disassembled to make internal cleaning convenient.





For products with special order specifications or options, if detailed instructions for the special order specifications or options are not contained in this manual, please contact TLV for full details.

This instruction manual is intended for use with the model(s) listed on the front cover. It is necessary not only for installation but for subsequent maintenance, disassembly/reassembly and troubleshooting. Please keep it in a safe place for future reference.

Safety Considerations

- Read this section carefully before use and be sure to follow the instructions.
- Installation, inspection, maintenance, repairs, disassembly, adjustment and valve opening/closing should be carried out only by trained maintenance personnel.
- The precautions listed in this manual are designed to ensure safety and prevent equipment damage and personal injury. For situations that may occur as a result of erroneous handling, three different types of cautionary items are used to indicate the degree of urgency and the scale of potential damage and danger: DANGER, WARNING and CAUTION.
- The three types of cautionary items above are very important for safety: be sure to observe all of them as they relate to installation, use, maintenance, and repair. Furthermore, TLV accepts no responsibility for any accidents or damage occurring as a result of failure to observe these precautions.

Symbols

	Indicates a DANGER, WARNING or CAUTION item.
	Indicates an urgent situation which poses a threat of death or serious injury
	Indicates that there is a potential threat of death or serious injury
	Indicates that there is a possibility of injury or equipment/product damage
	<p>Install properly and DO NOT use this product outside the recommended operating pressure, temperature and other specification ranges. Improper use may result in such hazards as damage to the product or malfunctions that may lead to serious accidents. Local regulations may restrict the use of this product to below the conditions quoted.</p> <p>Take measures to prevent people from coming into direct contact with product outlets. Failure to do so may result in burns or other injury from the discharge of fluids.</p> <p>When disassembling or removing the product, wait until the internal pressure equals atmospheric pressure and the surface of the product has cooled to room temperature. Disassembling or removing the product when it is hot or under pressure may lead to discharge of fluids, causing burns, other injuries or damage.</p>

Continued on the next page

 CAUTION	<p>Be sure to use only the recommended components when repairing the product, and NEVER attempt to modify the product in any way.</p> <p>Failure to observe these precautions may result in damage to the product and burns or other injury due to malfunction or the discharge of fluids.</p>
	<p>Use only under conditions in which no freeze-up will occur.</p> <p>Freezing may damage the product, leading to fluid discharge, which may cause burns or other injury.</p>
	<p>Use only under conditions in which no water hammer will occur.</p> <p>The impact of water hammer may damage the product, leading to fluid discharge, which may cause burns or other injury.</p>

Specifications



Install properly and **DO NOT** use this product outside the recommended operating pressure, temperature and other specification ranges. Improper use may result in such hazards as damage to the product or malfunctions which may lead to serious accidents. Local regulations may restrict the use of this product to below the conditions quoted.



Use only under conditions in which no freeze-up will occur. Freezing may damage the product, leading to fluid discharge, which may cause burns or other injury.

Refer to the indications on the spring housing for detailed specifications.

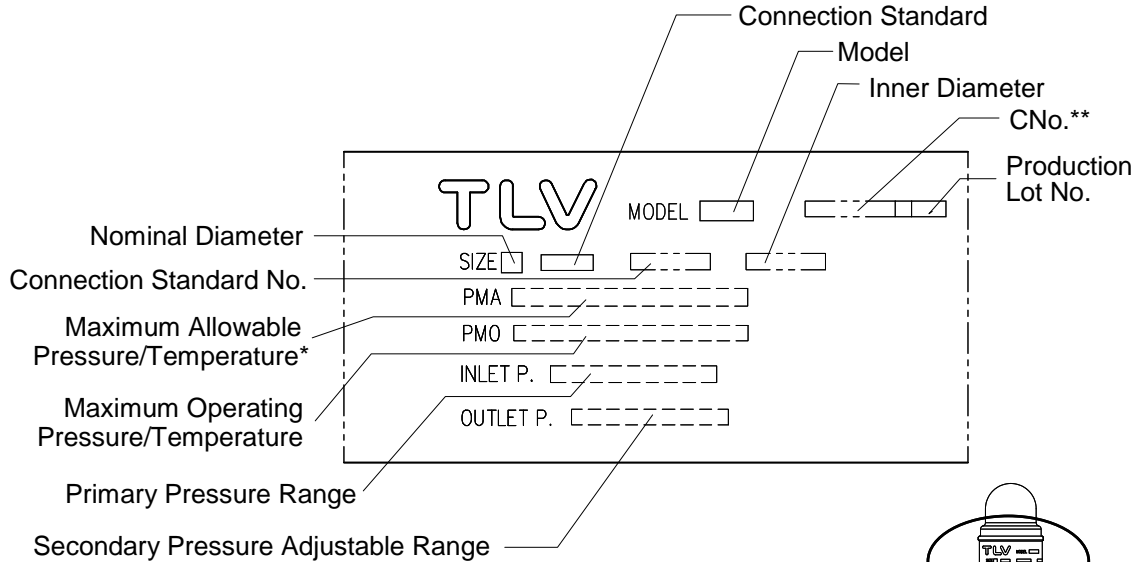

*Maximum allowable pressure (PMA) and maximum allowable temperature (TMA) are PRESSURE SHELL DESIGN CONDITIONS, **NOT** OPERATING CONDITIONS.

**CNo. (Charge/Mill No.) is displayed for products with options. This item is omitted when there are no options.

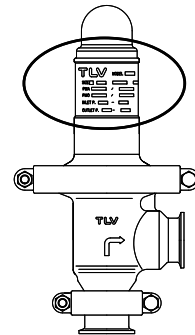

Acceptable Operating Range

Model	DR8-3P/DR8-3EP	DR8-6P/DR8-6EP
Primary Pressure Range	0.2 to 0.4 MPaG (30 to 60 psig)	0.4 to 0.8 MPaG (60 to 115 psig)
Adjustable Pressure Range	0.018 to 0.3 MPaG (2.5 to 45 psig)	0.27 to 0.6 MPaG (40 to 85 psig)
	No more than a maximum of 75% of the primary pressure	

(1MPa = 10.197 kg/cm²)

Correct Usage of the DR8 Direct-acting Pressure Reducing Valve

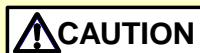

Install properly and **DO NOT** use this product outside the recommended operating pressure, temperature and other specification ranges. Improper use may result in such hazards as damage to the product or malfunctions which may lead to serious accidents. Local regulations may restrict the use of this product to below the conditions quoted.

1. The DR8 should be operated only within its specifications.
2. Installing an ON/OFF valve (solenoid valve or motorized valve)

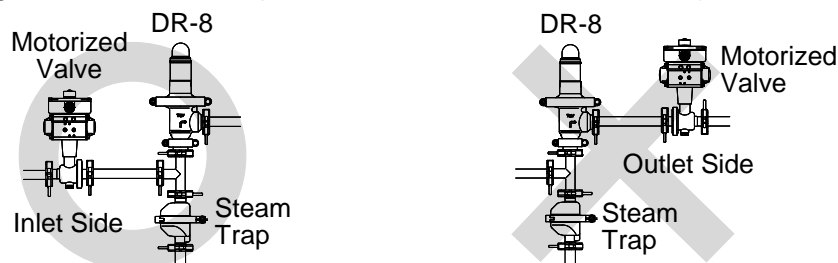

If an on-off valve, such as a motorized valve, is required to stop supply of steam to the steam-using equipment, install it at the inlet side of the DR8. If a solenoid valve is installed at the outlet of the DR8, it will cause heavy chattering and may lead to damage of the DR8. (When the on-off valve opens, the secondary pressure of the DR8 changes from zero to the set pressure, passing through an area of the reducing ratio of less than 30:1, where adjustment is impossible, chattering occurs momentarily.) To save energy, it is recommended to install the on-off valve as near to the boiler, as possible.

NOTE: To prevent water hammer, it is recommended that a slow-acting motorized on-off valve be used. In particular, if a fast-acting on-off solenoid valve is used for frequent temperature control, the potential water hammer effect can damage the steam-using equipment and the DR8.

3. Installing a control and/or safety valve

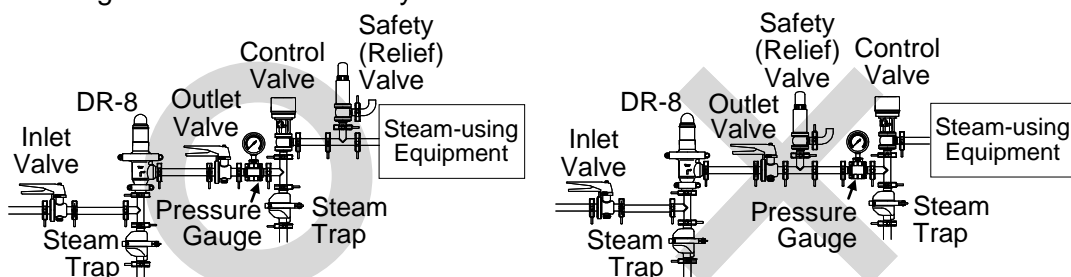

A control valve (i.e. for temperature control) installed between the DR8 and the steam-using equipment (downstream of the DR8) may raise the pressure between the DR8 and the control valve when the control valve is closed, depending on the spatial relationship. Therefore, a safety valve should be installed downstream of the control valve.

NOTE: When installing a safety valve to protect steam-using equipment, be sure to install it on, or directly before, the inlet of the steam-using equipment. If the safety valve is installed between the DR8 and a control valve, an eventual pressure rise could activate the safety valve.

4. Precautions for the installation of additional fittings before or after the DR8
 In order to ensure a stable steam flow, the piping upstream and downstream of the DR8 must be in straight runs. If the DR8 is installed either directly before or after an elbow or control valve, unevenness in steam flow may result in chattering and unstable pressure.

To ensure a stable steam flow, it is recommended that the DR8 be installed on straight runs of piping, as illustrated below.

- ① Inlet (primary side) of the pressure reducing valve (NOTE: d = pipe diameter)

Maintain a straight piping run of **10 d or more** when a Valve, Strainer, manual valve, a strainer or an elbow, etc. is installed.

(Example: if nominal size is 25 mm (1 in), have 250 mm (10 in) or more)

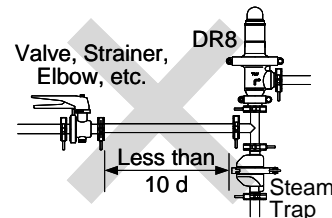
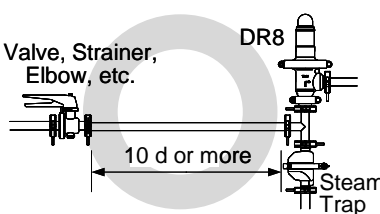

Maintain a straight piping run of **30 d or more** when an automatic valve (on-off valve) is installed.

(Example: if nominal size is 25 mm (1 in), have 750 mm (30 in) or more)

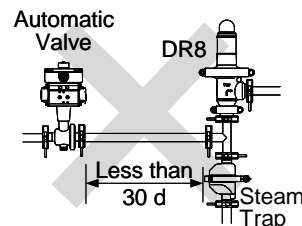
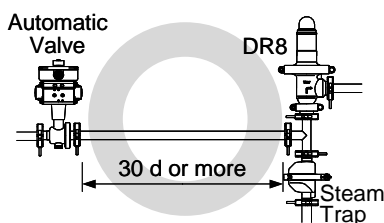

- ② Outlet (secondary side) of the pressure reducing valve

Maintain a straight piping run of **15 d or more** when a manual valve, a strainer or an elbow, etc. is installed.

(Example: if nominal size is 25 mm (1 in), have 375 mm (15 in) or more)

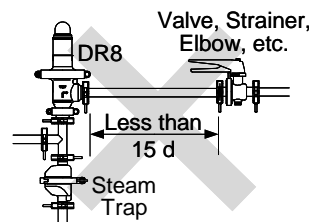
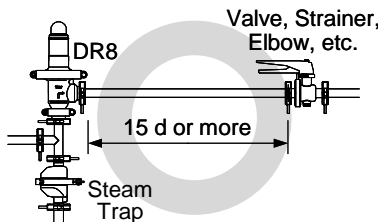

Maintain a straight piping run of **30 d or more** when a safety valve is installed.

(Example: if nominal size is 25 mm (1 in), have 750 mm (30 in) or more)

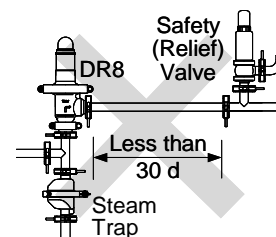
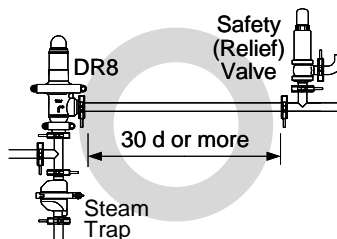

Maintain a straight piping run of **30 d or more** when another pressure reducing valve is installed. (Two-stage pressure reduction)

(Example: if nominal size is 25 mm (1 in), have 750 mm (30 in) or more)

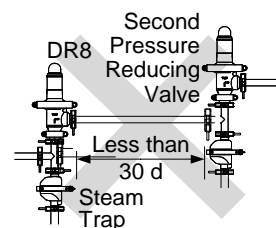
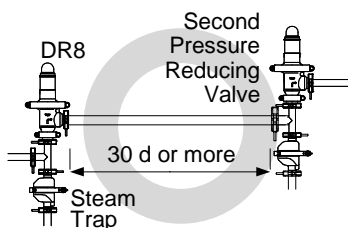

Configuration

Size 40 mm

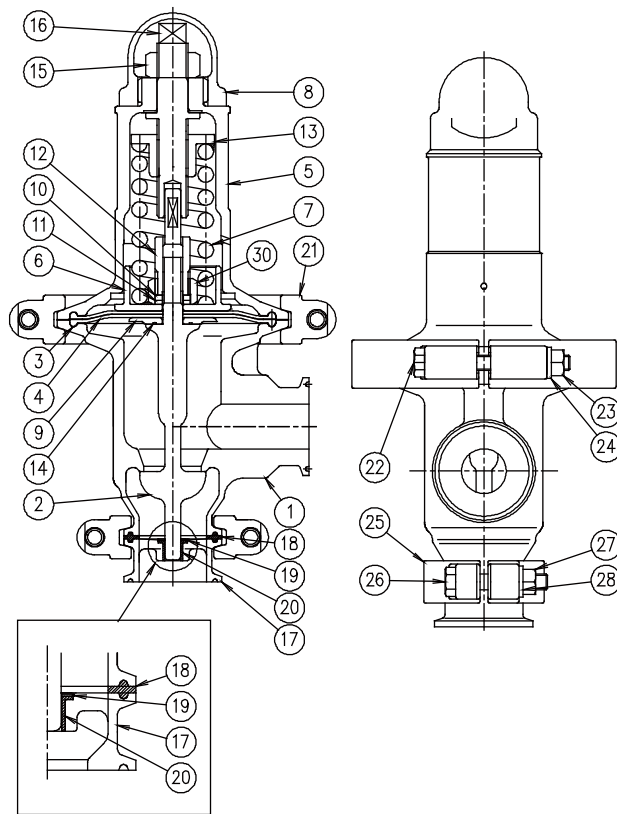

Sizes 15 to 20 mm

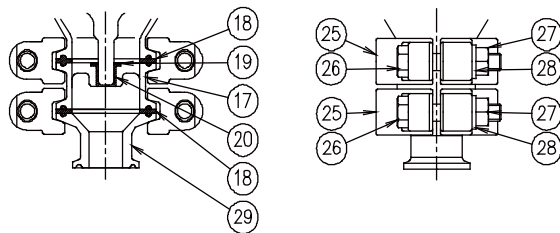

Size 25 mm

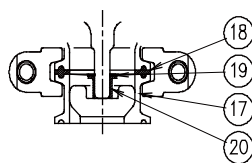

No.	Name	A*1	B*1	C*1
1	Body			
2	Valve		✓	
3	Diaphragm	✓	✓	
4	Protective Sheet	✓	✓	
5	Spring Housing			
6	Upper Diaphragm Retainer			
7	Coil Spring*2		✓	
8	Cap			
9	Lower Diaphragm Retainer		✓	
10	Plain Washer		✓	
11	Spring Washer		✓	
12	High Nut		✓	
13	Spring Retainer*2		✓	
14	Retainer Gasket	✓	✓	
15	Locknut			
16	Adjustment Screw	✓		
17	Valve Guide			✓
18	Inlet Clamp Gasket*3	✓	✓	✓
19	Snap Ring			✓
20	Slide Bearing			✓
21	Body Clamp			
22	Body Clamp Bolt*4			
23	Body Clamp Nut*4			
24	Spring Washer*4			
25	Inlet Clamp*4			
26	Inlet Clamp Bolt*5			
27	Inlet Clamp Nut*5			
28	Spring Washer*5			
29	Adapter*6			
30	Coil Spring Guide		✓	

*1 Replacement parts are available only in the following kits:

- A: Maintenance Kit
- B: Repair Kit for Diaphragm/Valve
- C: Repair Kit for Valve Guide

*2 The spring retainer and coil spring guide cannot be removed individually as they are incorporated with the coil spring.

*3 Number of parts for sizes 15 to 20 mm (1/2 to 3/4 in): 2 pieces, 25 mm (1 in): 1 piece

*4 Number of parts: 2 pieces

*5 Number of parts for sizes 15 to 20 mm (1/2 to 3/4 in): 4 pieces, 25 mm (1 in): 2 pieces

*6 For sizes 15 to 20 mm (1/2 to 3/4 in) only

Installation



Install properly and **DO NOT** use this product outside the recommended operating pressure, temperature and other specification ranges. Improper use may result in such hazards as damage to the product or malfunctions which may lead to serious accidents. Local regulations may restrict the use of this product to below the conditions quoted.



Take measures to prevent people from coming into direct contact with product outlets. Failure to do so may result in burns or other injury from the discharge of fluids.

Installation, inspection, maintenance, repairs, disassembly, adjustment and valve opening/closing should be carried out only by trained maintenance personnel.

1. Removing the Protective Caps

Before installation, be sure to remove all protective seals and caps covering the product inlet and outlets. (Found in 2 locations)

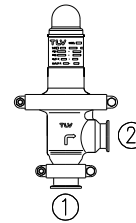

2. Tolerance Angle for Installation

Make sure the DR8 is installed vertically so that the arrow mark on the body matches the direction of steam flow, the outlet is horizontal, and the adjustment screw section faces up. Allowable inclination is 10 degrees in the fore-aft direction and 15 degrees side to side in the plane perpendicular to the steam flow line.

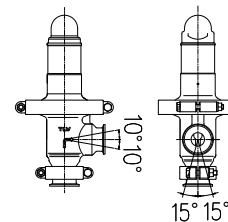

3. Piping Support

Install the DR8, paying attention to avoid excessive load, bending and vibration. It is recommended that the inlet and outlet pipes be supported securely.

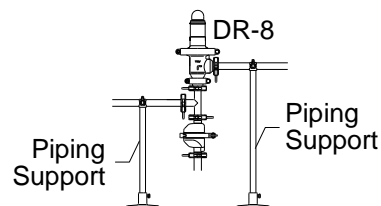

4. Maintenance Space

Leave sufficient space for maintenance, inspection and repair.

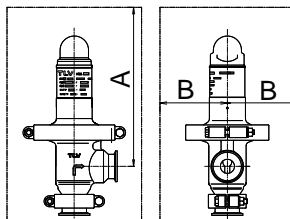

A: 260 mm (10¹/₄ in)

B: 110 mm (4¹/₂ in)

5. Piping Size

If the secondary steam flow velocity is expected to be more than 30 m/s (100 ft/s), install a diffuser in order to keep the flow velocity below 30 m/s (100 ft/s). If the distance between the DR8 and the steam-using equipment is great, a possible drop in pressure should be taken into consideration when selecting the piping size.

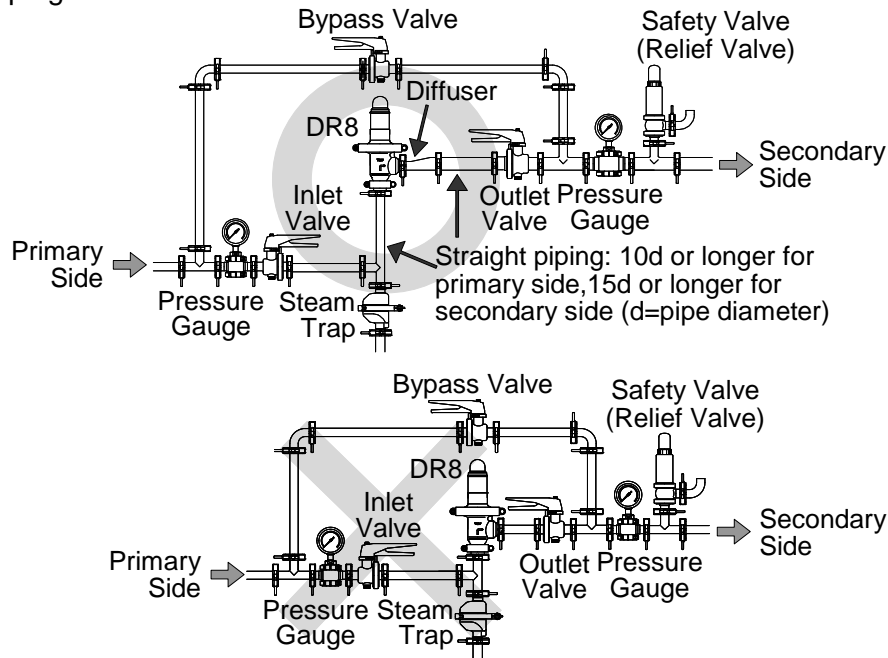

6. Two-stage Pressure Reduction

Employ 2-stage pressure reduction if the required reduction is not possible due to DR8 operating range limitations (when it is not possible to reduce to the desired pressure using a single pressure reducing valve).

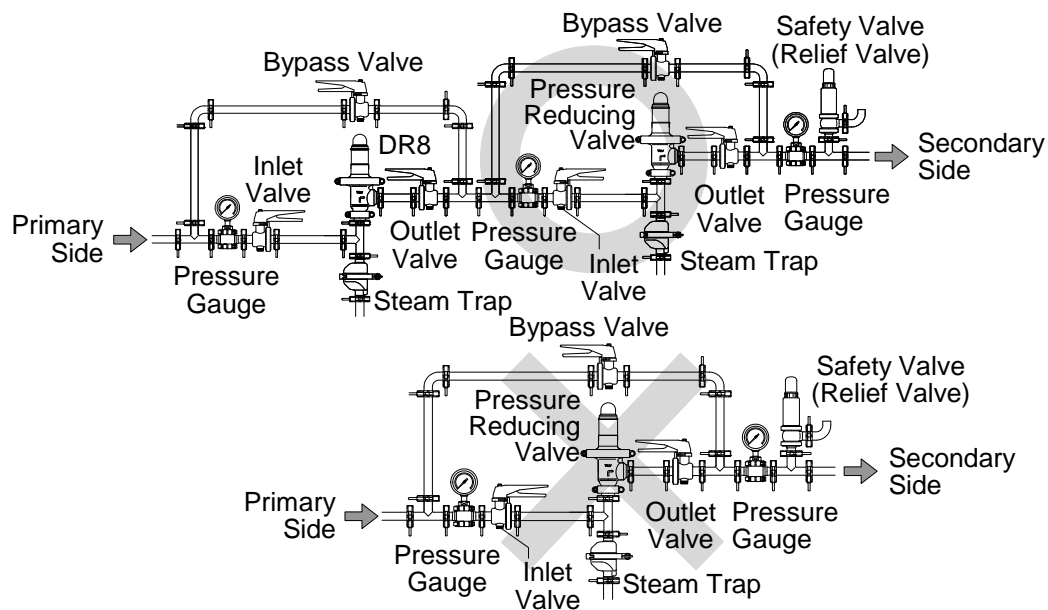

7. Accessories

Always install a bypass line. At the inlet and outlet, install a pressure gauge and a shut-off valve. Ball valves, which will not retain condensate, are recommended for inlet/outlet shut-off valves. The nominal pipe size for the bypass line should be $\frac{1}{2}$ or greater of the primary pipe size.

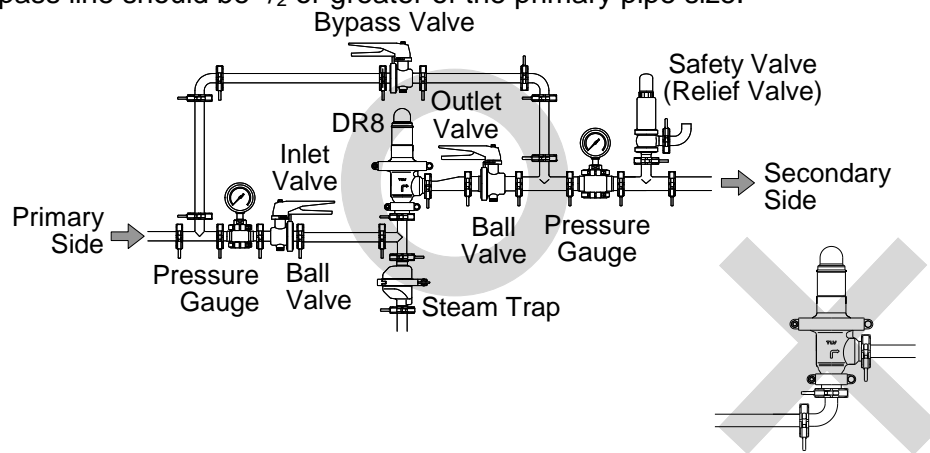

8. Blowdown (Installing the bypass valve)

Before installing the DR8 or supplying steam to the DR8, be sure to blow down all piping thoroughly. Installing the bypass valve makes blowdown easier. Blowdown is especially important for newly installed piping or after the system has been shut down for a long period of time. This will reduce operation failure caused by condensate or foreign matter. The bypass valve should not be opened too quickly. If a safety valve (or relief valve) is installed, perform blowdown staying clear of pressurized blow-out.

If condensate accumulates while the inlet valve is closed, install a steam trap that has a sufficient discharge capacity considering the initial condensate discharge amount.

To perform blowdown, close the inlet valve (A) first, then the outlet valve (B), and open the bypass valve (C). Do not open valves too quickly.

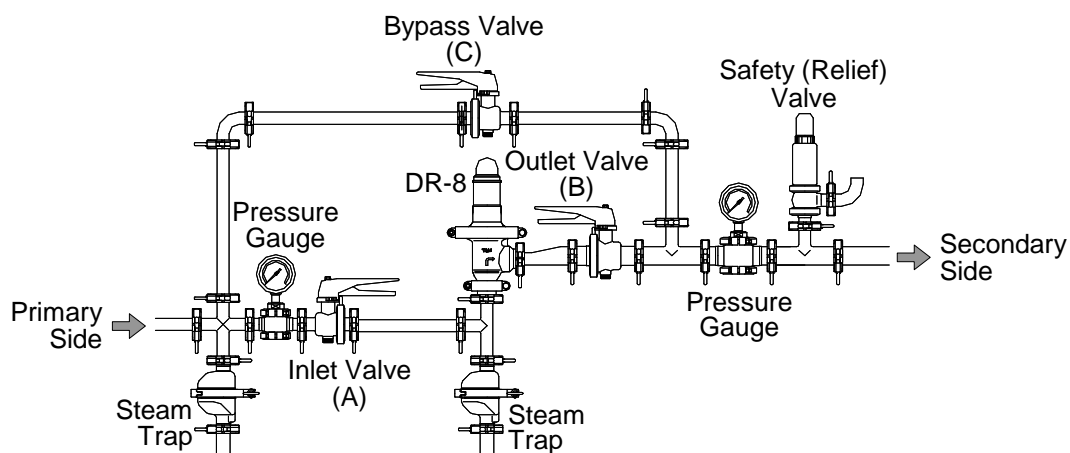

Adjustment



Use only under conditions in which no water hammer will occur. The impact of water hammer may damage the product, leading to fluid discharge, which may cause burns or other injury.

To avoid problems such as water hammer and to protect steam-using equipment, the DR8 should be correctly adjusted.

1. It is necessary to blow down all pipe lines thoroughly. The blowdown is especially important if the line is new or has been shut down for a long period of time. Take particular care to ensure that matter such as condensate and dirt does not remain inside the steam-using equipment. (Stay clear of any pressurized blow-out from the safety valve.)
2. Make sure that the shut-off and bypass valves located upstream and downstream of the DR8 are completely closed.
3. Remove the cap and loosen the locknut, then turn the adjustment screw counterclockwise to free the coil spring.

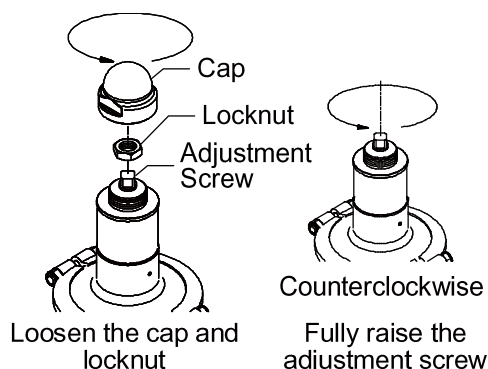

4. Slowly, fully open the shut-off valve at the inlet of the DR8.
5. Slightly open the shut-off valve at the outlet of the DR8.
6. Turn the adjustment screw clockwise until the desired outlet pressure is obtained. Wait several minutes.

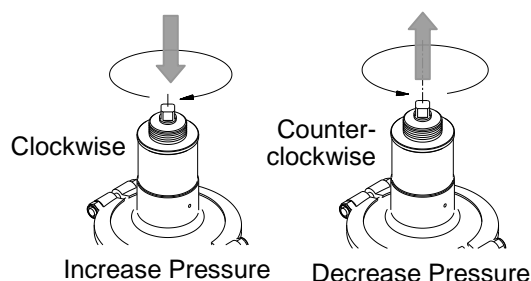

7. Slowly, fully open the shut-off valve at the outlet of the DR8.
8. After setting, hold the adjustment screw and retighten the locknut.
9. When shutting down the system, always close the outlet shut-off valve first and then the inlet valve. (If the inlet shut-off valve is closed first, the safety valve may be tripped.)

Maintenance



Take measures to prevent people from coming into direct contact with product outlets. Failure to do so may result in burns or other injury from the discharge of fluids.



Be sure to use only the recommended components when repairing the product, and NEVER attempt to modify the product in any way. Failure to observe these precautions may result in damage to the product or burns or other injury due to malfunction or the discharge of fluids.

Parts Inspection

When parts have been removed, or during periodic inspections, use the following table to inspect the parts and replace any that are found to be defective.

Part	Inspection and Maintenance Frequency
Diaphragm, Protective Sheet	If hunting or chattering takes place, cracks or fatigue may develop in a short period of time.
Valve, Body	If there is chattering or dirt, premature wear may result.
Valve Guide, (Slide Bearing)	If hunting or chattering takes place, premature wear may result.

Disassembly



When disassembling or removing the product, wait until the internal pressure equals atmospheric pressure and the surface of the product has cooled to room temperature. Disassembling or removing the product when it is hot or under pressure may lead to discharge of fluids, causing burns, other injuries or damage.

It is a recommended practice to dismantle and inspect the DR8 once a year for preventive maintenance purposes. It is especially important to perform an inspection immediately after the initial run of a new line or before or after equipment such as a heater is out of service for a long period of time. (Installation, inspection, maintenance, repairs, disassembly, adjustment and valve opening/closing should be carried out only by trained maintenance personnel.)

Remove all steam from the piping (both upstream and downstream). Wait for the body to cool before attempting to remove the DR8 from the line. Then remove the DR8 from the piping, and secure it in a vise to perform the inspection.

Disassembling the Adjustment Section

Loosen the cap and the locknut first. Loosen the adjustment screw completely and remove the body clamp.

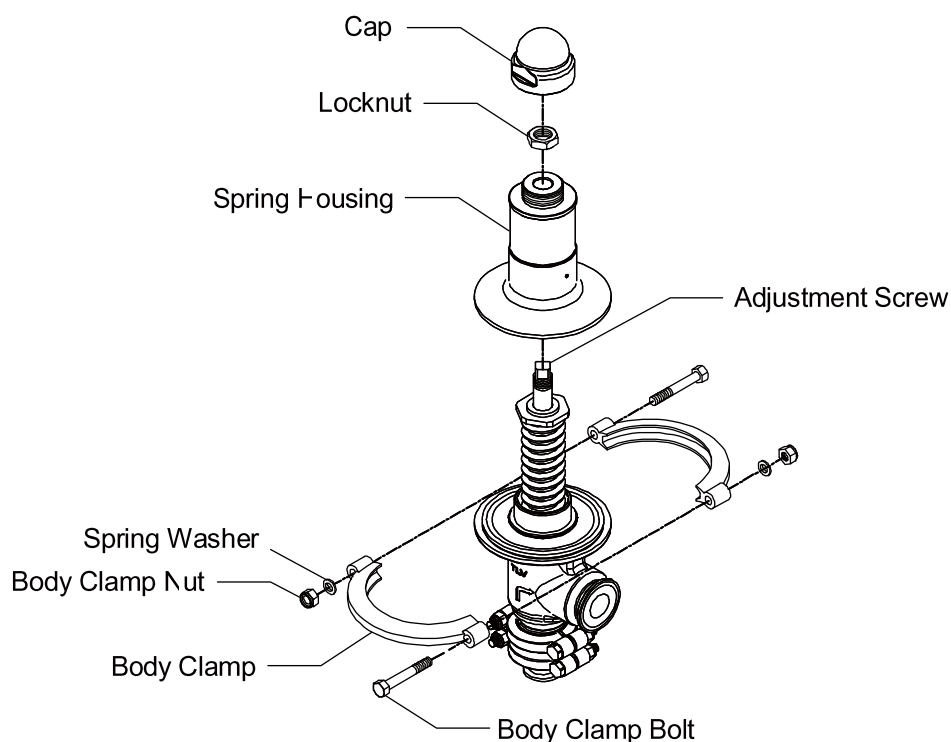

After removing the spring housing, loosen the spring retainer by turning it counterclockwise

⇒ Check for seizure or any damaged screw threads.

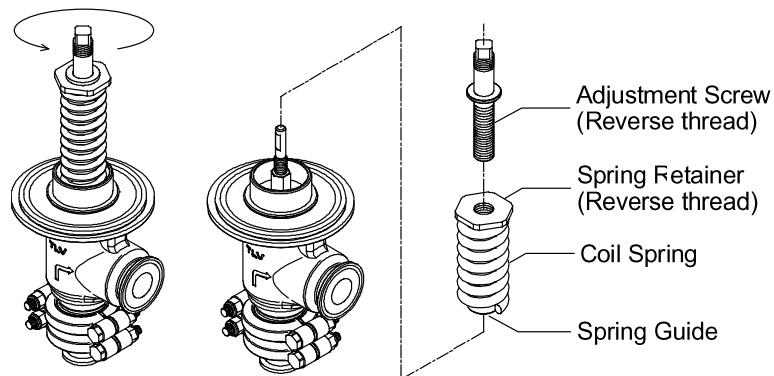

NOTE: The spring retainer and coil spring guide cannot be removed individually as they are incorporated with the coil spring.

Disassembling the Diaphragm Section

Hold the valve in place with an adjustable wrench across the flats on the upper part of the valve and use another wrench to remove the high nut. After removing the high nut, remove the plain washer, the upper diaphragm retainer and the diaphragm.

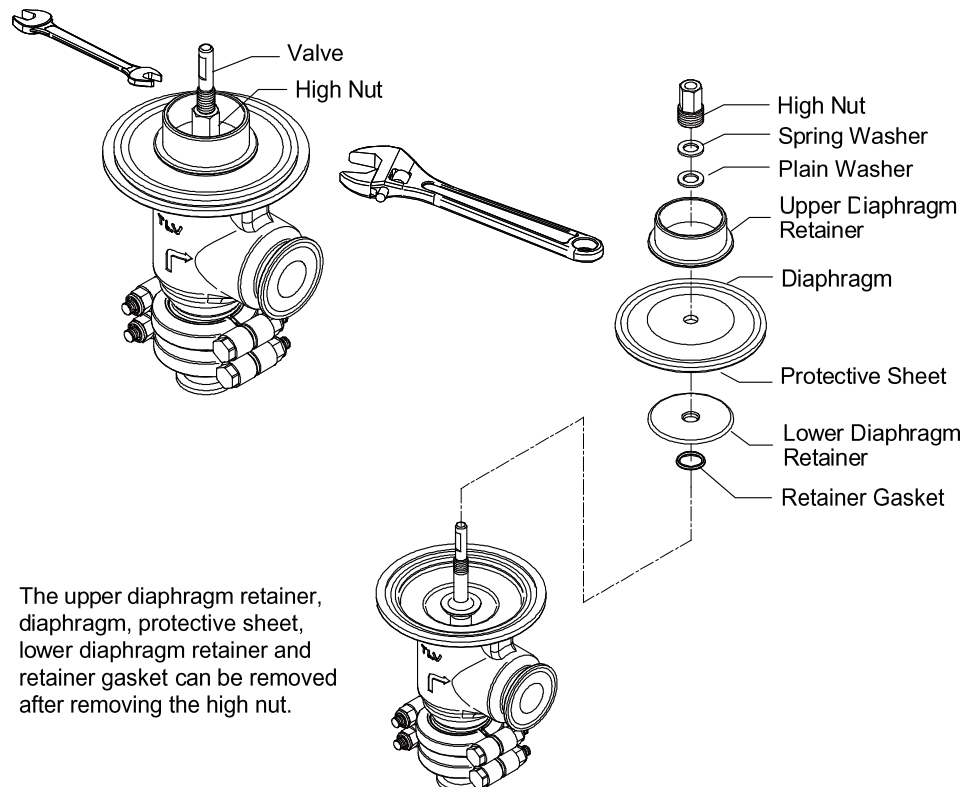

Disassembling the Valve Section

Remove the inlet clamp(s) holding the body, valve guide and adapter (for sizes 15 to 20 mm ($\frac{1}{2}$ to $\frac{3}{4}$ in) only).

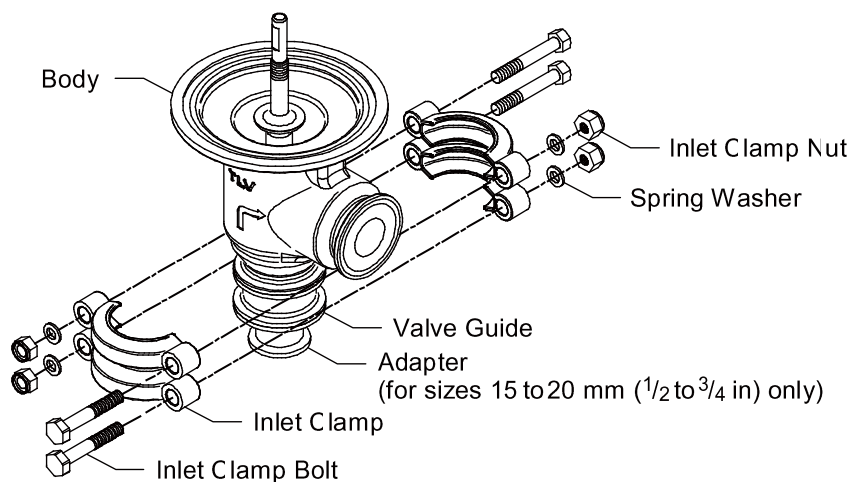

Remove the adapter and the inlet clamp gasket.
(for sizes 15 to 20 mm ($\frac{1}{2}$ to $\frac{3}{4}$ in) only)

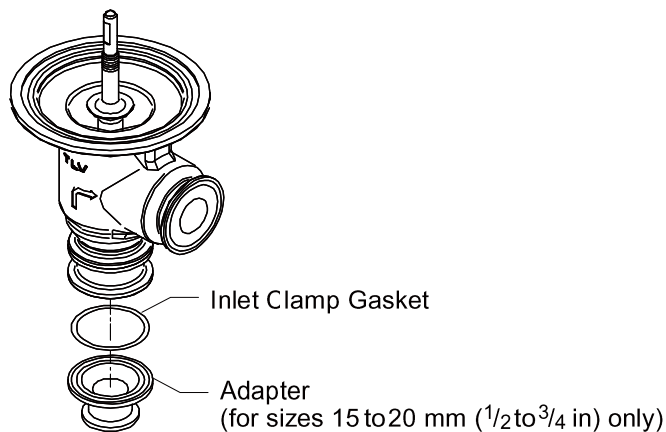

Separate the valve guide from the body. The valve comes off with the valve guide.

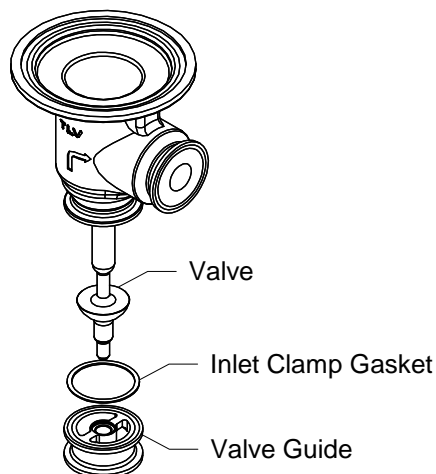

Disassembling the Valve Guide Section

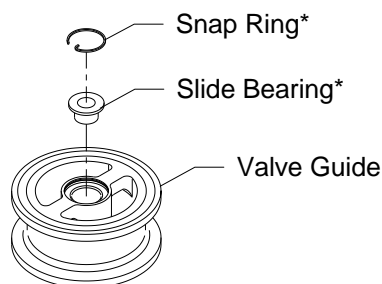

*The slide bearing and snap ring cannot be removed individually as they are incorporated with the valve guide and must be replaced as a set with the valve guide.

Cleaning

After inspecting for scratches, erosion, etc. on the seating surface of the body and valve, cracks or deterioration of the diaphragm and protective sheet, wear on the valve guide, cracks or deterioration of the retainer gasket, and if there are no abnormalities, clean and reassemble the parts.

The following parts will require cleaning before reassembly:

Diaphragm, protective sheet, valve, valve guide, retainer gasket, body, lower diaphragm retainer, adapter (for sizes 15 to 20 mm ($1/2$ to $3/4$ in) only)

NOTE: Avoid using solvent to clean these parts as it may accelerate deterioration of the diaphragm, protective sheet, and resin part of the valve guide and retainer gasket.

Exploded View

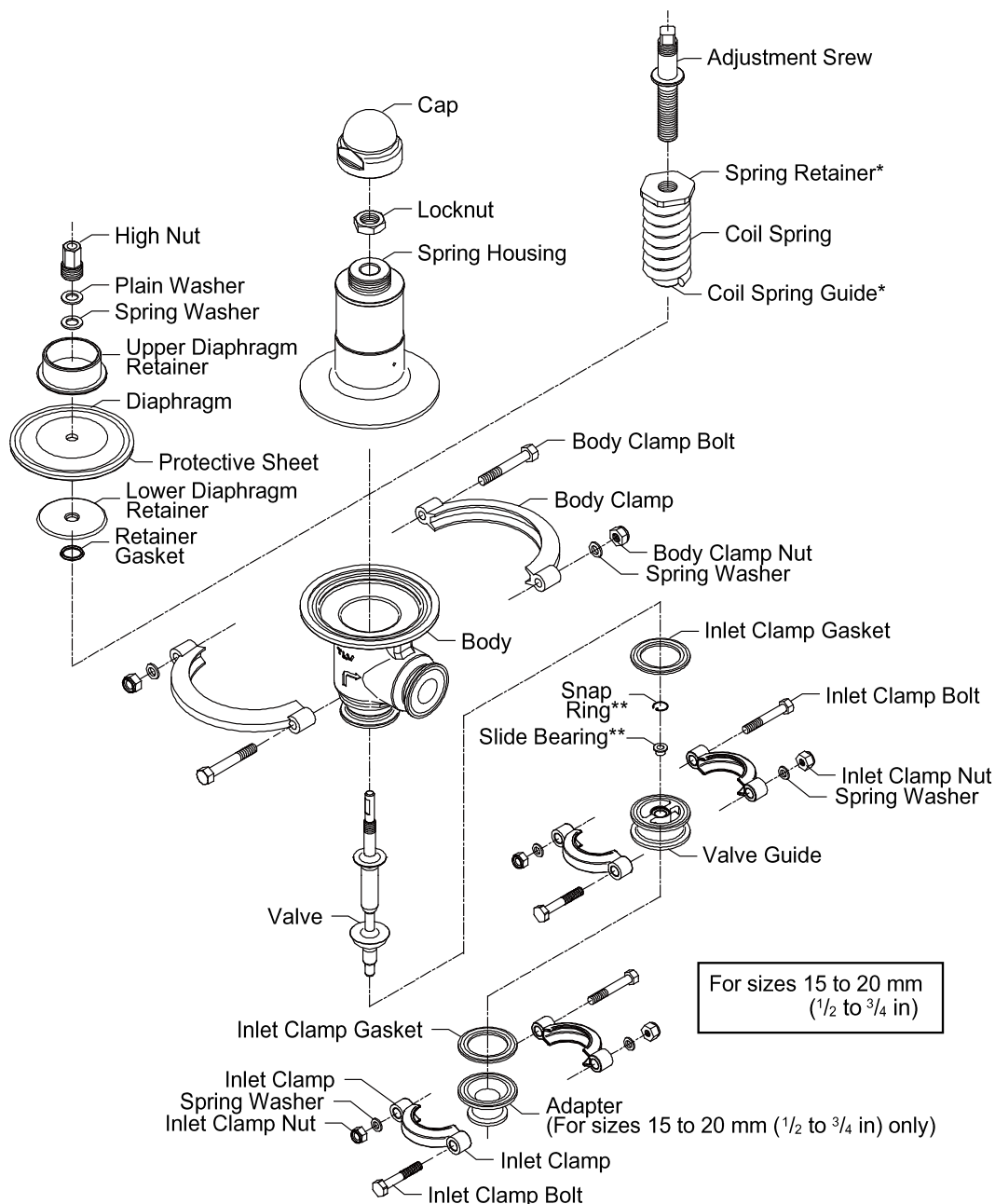

* The spring retainer and coil spring guide cannot be removed individually as they are incorporated with the coil spring.

** The slide bearing and snap ring cannot be removed individually as they are incorporated with the valve guide and must be replaced as a set with the valve guide.

Reassembly

Reassemble the unit using the same procedure as used for disassembly; but in reverse order. In addition, observe the following precautions:

1. The diaphragm and the protective sheet also perform the role of gaskets and may be re-used if free from cracks, deterioration or deformation. If any abnormalities are found, these parts need to be replaced. The protective sheet must fit to the groove of the body. Make sure that the convex portion of the diaphragm faces up.

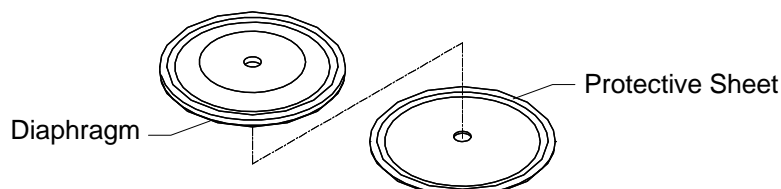

2. Make sure there are no scratches or erosion on the surface of the valve seat section of the body and seating surface of the valve, as this will lead to leakage. If no abnormalities are found, these parts can be reused. When there are scratches or erosion on these parts, the body and/or valve need to be replaced.

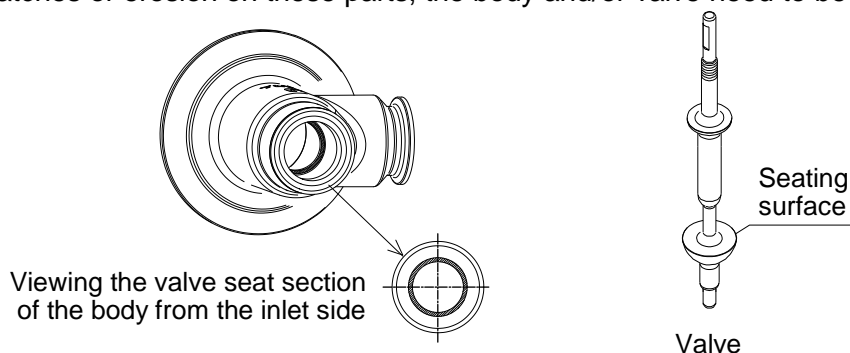

3. The retainer gasket may be re-used if it has no cracks or deterioration. If any abnormalities are found, it needs to be replaced.
4. Applying anti-seize to all non-wetted threaded parts is recommended.

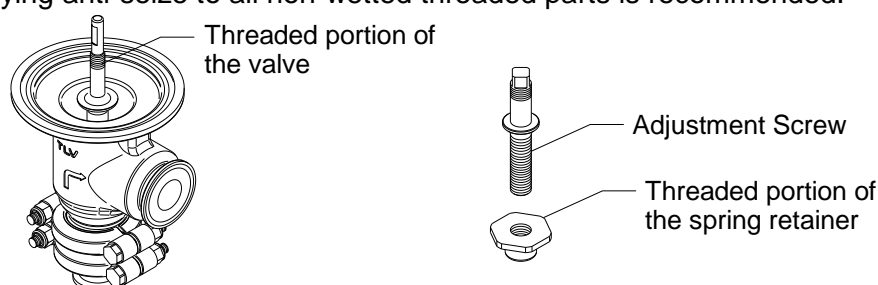

5. Standard torques for fastening the respective screws and the width across flats of the tools to be used are as follows:

Part	Torque		Distance Across Flats	
	N·m	(lbf·ft)	mm	(in)
High Nut	3	(2.2)	14	(⁹ / ₁₆)
Body Clamp Nut, Inlet Clamp Nut	3	(2.2)	17	(²¹ / ₃₂)

(1 N·m ≈ 10 kg·cm)

NOTE: If drawings or other special documentation were supplied for the product, any torque given there takes precedence over values shown here.

Troubleshooting



When disassembling or removing the product, wait until the internal pressure equals atmospheric pressure and the surface of the product has cooled to room temperature. Disassembling or removing the product when it is hot or under pressure may lead to discharge of fluids, causing burns, other injuries or damage.

This product is shipped after stringent checks and inspection, and should perform its intended function for a long period of time without failure. However, should there be any problems encountered in the operation of the DR8, consult the troubleshooting guide below. Problems are classified as follows:

1. The secondary pressure does not increase
2. The secondary pressure cannot be adjusted or increases abnormally
3. Hunting (fluctuation of the secondary pressure) occurs
4. Chattering (a heavy mechanical noise) occurs
5. Abnormal noises

Major causes for the above problems are usage under non-specified conditions (out of specification), insufficient pressure or flow rate, and clogs by dirt and scale. To ensure performance for a long period of time, it is recommended that the "Acceptable Operating Range", "Correct Usage of the DR8 Direct-acting Pressure Reducing Valve" and "Adjustment" sections be reviewed.

Problem	Symptom	Cause	Remedy
The secondary pressure does not rise	Pressure does not increase	No steam is being supplied	Check the primary/secondary piping and valves of the unit
		The valve at the primary side is closed	
		The filter at the primary side is clogged	Clean or blow down or replace with a new filter
		Flow rate exceeds specifications	Check the flow rate; check the model selection, replace with a more suitable unit if necessary*
		The secondary pressure exceeds the adjustable range	Check the model selection, replace with a more suitable unit if necessary*
The secondary pressure cannot be adjusted or increases abnormally	Adjustment is difficult and set pressure varies	The flow rate is too low	Check the flow rate; check the model selection, replace with a more suitable unit if necessary*
		Pressure fluctuation at the primary side is large	Check the primary pressure; check the model selection, replace with a more suitable unit if necessary*
		Flow rate fluctuation is too large	Check the flow rate, re-set the pressure; check the model selection, replace with a more suitable unit if necessary*
		The adjustment screw has seized	Replace with a new adjustment screw

*For model selection and replacement, contact TLV.

Problem	Symptom	Cause	Remedy
The secondary pressure cannot be adjusted or increases abnormally	Adjustment is difficult and set pressure varies	The slide bearing is distorted or damaged	Replace with a new valve guide (when replacing the slide bearing or snap ring, these parts need to be replaced as a set with the valve guide)
		The diaphragm or protective sheet is distorted or damaged	Replace with a new diaphragm and protective sheet
		The selected model is inappropriate for the service conditions (specifications)	Check the model selection, replace with a more suitable unit if necessary*
	Upon closing the valves at the secondary side, the secondary pressure abruptly rises as high as the primary pressure	The bypass valve is leaking	Check, clean, and replace with a new bypass valve if necessary*
		There is a build-up of dirt on or damage to the valve or the valve seat	Clean and align
Hunting or chattering occurs	Occurs at low steam demand	Flow rate is too low	Check the flow rate; check the model selection, replace with a more suitable unit if necessary*
	Hunting never stops	The reduction ratio is too high	Use two-stage reduction
		The selected model is inappropriate for the service conditions (specifications)	Check the model selection, replace with a more suitable unit if necessary*
	Chattering never stops	Condensate is entrained	Install a separator or a steam trap; check the piping
The selected model is inappropriate for the service conditions (specifications)		Check the model selection, replace with a more suitable unit if necessary*	
Abnormal noises	Makes a high-pitched noise	The required pressure reduction exceeds specifications	Use two-stage reduction
		Flow rate exceeds specifications	Check the flow rate; check the model selection, replace with a more suitable unit if necessary*
		The valve installed close to the reducing valve opens/closes too quickly	Install the valve at as great a distance away as possible

*For model selection and replacement, contact TLV.

NOTE: When replacing parts with new, use the parts list for reference and replace with parts from the Maintenance Kit, Repair Kit, etc. (Please note that replacement parts are only available in pre-packaged kits.)

Product Warranty

1. Warranty Period
One year following product delivery.
2. Warranty Coverage
TLV CO., LTD. warrants this product to the original purchaser to be free from defective materials and workmanship. Under this warranty, the product will be repaired or replaced at our option, without charge for parts or labor.
3. This product warranty will not apply to cosmetic defects, nor to any product whose exterior has been damaged or defaced; nor does it apply in the following cases:
 - 1) Malfunctions due to improper installation, use, handling, etc., by other than TLV CO., LTD. authorized service representatives.
 - 2) Malfunctions due to dirt, scale, rust, etc.
 - 3) Malfunctions due to improper disassembly and reassembly, or inadequate inspection and maintenance by other than TLV CO., LTD. authorized service representatives.
 - 4) Malfunctions due to disasters or forces of nature.
 - 5) Accidents or malfunctions due to any other cause beyond the control of TLV CO., LTD.

Under no circumstances will TLV CO., LTD. be liable for consequential economic loss damage or consequential damage to property.

* * * * *

For Service or Technical Assistance:

Contact your TLV representative or your regional TLV office.

Manufacturer

TLV CO., LTD.

881 Nagasuna, Noguchi
Kakogawa, Hyogo 675-8511 JAPAN
Tel: 81-(0)79-427-1800