



Manufacturer

TLV CO., LTD.

Kakogawa, Japan

is approved by LRDA Ltd. to ISO 9001/14001



Instruction Manual

Pneumatic Control Valve with Built-in Separator and Steam Trap CV-COS

Copyright © 2019 by TLV CO., LTD.

All rights reserved

Contents

Introduction	2
Safety Considerations	3
Specifications	5
Configuration	7
Installation	8
Electrical Wiring	11
Operational Check	12
Maintenance.....	14
Disassembly/Reassembly	15
Troubleshooting.....	19
Product Warranty	21
Options.....	22

Introduction

Thank you for purchasing the TLV pneumatic control valve with built-in separator and steam trap.

This product has been thoroughly inspected before being shipped from the factory. When the product is delivered, before doing anything else, check the specifications and external appearance to make sure nothing is out of the ordinary. Also be sure to read this manual carefully before use and follow the instructions to be sure of using the product properly.







The TLV pneumatic control valve with built-in separator and steam trap is a revolutionary product that combines an integrated positioner/diaphragm-type actuator with a separator and a steam trap. Steam-using equipment can achieve its intended efficiency only if the steam being used is very dry. Using steam in which matter such as condensate, scale or types of grease is entrained can not only result in problems with the steam-using equipment and in lowered productivity, but can also lead to shortened service life for and malfunction of the control valve. The CV-COS is a new control valve that offers a solution for these problems by supplying high-quality steam to the process and offering maximum productivity.

This instruction manual is intended for use with the model(s) listed on the front cover. It is needed not only for installation, but also for subsequent maintenance, disassembly/reassembly and troubleshooting. Please keep it in a safe place for future reference.

Safety Considerations

- Read this section carefully before use and be sure to follow the instructions.
- Installation, inspection, maintenance, repairs, disassembly, adjustment and valve opening/closing should be carried out only by trained maintenance personnel.
- The precautions listed in this manual are designed to ensure safety and prevent equipment damage and personal injury. For situations that may occur as a result of erroneous handling, three different types of cautionary items are used to indicate the degree of urgency and the scale of potential damage and danger: DANGER, WARNING and CAUTION.
- The three types of cautionary items above are very important for safety: be sure to observe all of them as they relate to installation, use, maintenance and repair. Furthermore, TLV accepts no responsibility for any accidents or damage occurring as a result of failure to observe these precautions.

Symbols

	Indicates a DANGER, WARNING or CAUTION item.
	DANGER Indicates an urgent situation which poses a threat of death or serious injury
	WARNING Indicates that there is a potential threat of death or serious injury
	CAUTION Indicates that there is a possibility of injury or equipment / product damage
	NEVER apply direct heat to the float. The float may explode due to increased internal pressure, causing accidents leading to serious injury or damage to property and equipment.
	Install properly and DO NOT use this product outside the recommended operating pressure, temperature and other specification ranges. Improper use may result in such hazards as damage to the product or malfunctions that may lead to serious accidents. Local regulations may restrict the use of this product to below the conditions quoted.
	DO NOT use the product in excess of the maximum operating pressure differential. Such use could make discharge through the steam trap impossible (blocked).
	Use hoisting equipment for heavy objects (weighing approximately 20 kg (44 lb) or more). Failure to do so may result in back strain or other injury if the object should fall.
	Take measures to prevent people from coming into direct contact with product outlets. Failure to do so may result in burns or other injury from the discharge of fluids.

Continued on next page

 CAUTION	<p>When disassembling or removing the product, wait until the internal pressure equals atmospheric pressure and the surface of the product has cooled to room temperature. Disassembling or removing the product when it is hot or under pressure may lead to discharge of fluids, causing burns, other injuries or damage.</p>
	<p>Be sure to use only the recommended components when repairing the product, and NEVER attempt to modify the product in any way. Failure to observe these precautions may result in damage to the product and burns or other injury due to malfunction or the discharge of fluids.</p>
	<p>Do not use excessive force when connecting threaded pipes to the product. Over-tightening may cause breakage leading to fluid discharge, which may cause burns or other injury.</p>
	<p>Use only under conditions in which no freeze-up will occur. Freezing may damage the product, leading to fluid discharge, which may cause burns or other injury.</p>
	<p>Use only under conditions in which no water hammer will occur. The impact of water hammer may damage the product, leading to fluid discharge, which may cause burns or other injury.</p>
	<p>Make sure the power supply is OFF before carrying out work on the wiring or inspections involving disassembly. If such work is carried out with the power on, there is a danger that equipment may malfunction or electric shock may occur, leading to injury or other accidents.</p>
	<p>Make sure that wiring work requiring a special license is carried out by qualified personnel. If carried out by unqualified personnel, overheating or short circuits leading to injury, fires, damage or other accidents may occur.</p>
	<p>When using this product, NEVER stand close to, or leave tools anywhere near, moving parts, such as the shaft. Contact with moving parts or objects becoming caught in moving parts could lead to injury or damage or other accidents.</p>

Specifications



Install properly and **DO NOT** use this product outside the recommended operating pressure, temperature and other specification ranges. Improper use may result in such hazards as damage to the product or malfunctions which may lead to serious accidents. Local regulations may restrict the use of this product to below the conditions quoted.



DO NOT use the product in excess of the maximum operating pressure differential; such use could make discharge impossible (blocked).



Use only under conditions in which no freeze-up will occur. Freezing may damage the product, leading to fluid discharge, which may cause burns or other injury.

Refer to the product nameplate*** for detailed specifications.

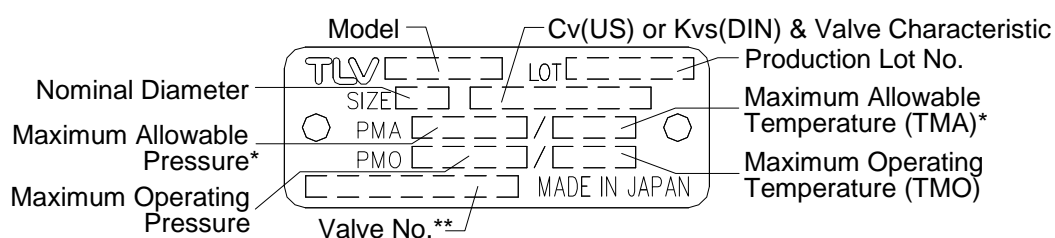

* Maximum allowable pressure (PMA) and maximum allowable temperature (TMA) are PRESSURE SHELL DESIGN CONDITIONS, **NOT** OPERATING CONDITIONS.

** Valve No. is displayed for products with options. This item is omitted from the nameplate when there are no options.

*** Nameplate layout depends on product specifications.

Actuator/Pneumatic Positioner

Actuator Area	120 cm ² (18.6 in ²)
Operation	Air-to-Open (Reverse Action)
Air Supply Connection Port	Pneumatic positioner body G ^{1/4} (with adapter for G ^{1/4} x RC ^{1/4} , BSPT ^{1/4} or NPT ^{1/4})
Maximum Air Supply Pressure	0.6 MPaG (85 psig)
Motive Medium	Oil-free air, filtered to 5 μm
Air Consumption	At air supply pressure 0.4 MPaG: 0.16 Nm ³ /h (55 psig: 5.65 ft ³ /h)
Electrical Input Signal/Resistance	4 to 20 mA DC / approximately 300 Ω
Electrical Connection Port	PG11
Protection Class	IP54 (dust and splash-proof type)
Allowable Ambient Temperature Range	-10 to 60 °C (14 to 140 °F)
Material	Die cast aluminum/synthetic resin

Air Supply Pressure

Size	Pressure Supplied to Filter Regulator	Air Pressure Supplied to Positioner	Air Pressure Supplied to Actuator (Spring Range)
15 – 50 mm (1/2 – 2 in)	0.40 – 0.60 MPaG (55 – 85 psig)	0.38 MPaG (54 psig)	0.21 – 0.33 MPaG (30 – 48 psig)

(1 MPa = 10.197 kg/cm²)

Valve

Size mm (in)	15 (1/2)	20 (3/4)	25 (1)	40 (1 1/2)	50 (2)	
Maximum Operating Pressure (PMO)	See nameplate					
Maximum Operating Temperature (TMO)						
Applicable Fluid	Steam					
Valve Plug & Stem/ Valve Seat Material	Stainless steel					
Valve Characteristic	Equal percentage					
Stroke (Travel)	15 mm (9/16 in)					
Rangeability	50 : 1					
Cv and Kvs Values	Cv (US)	3.5	6.0	9.0	27	40
	Cv (UK)	2.9	5.0	7.5	23	33
	Kvs (DIN)	3.0	5.1	7.7	23	34
Valve Leakage Rate (Leak Rate Class)	Less than 0.01% of the rated Cv and Kvs value (IEC/ANSI/EN Class IV)					

(1 MPa = 10.197 kg/cm²)

Configuration

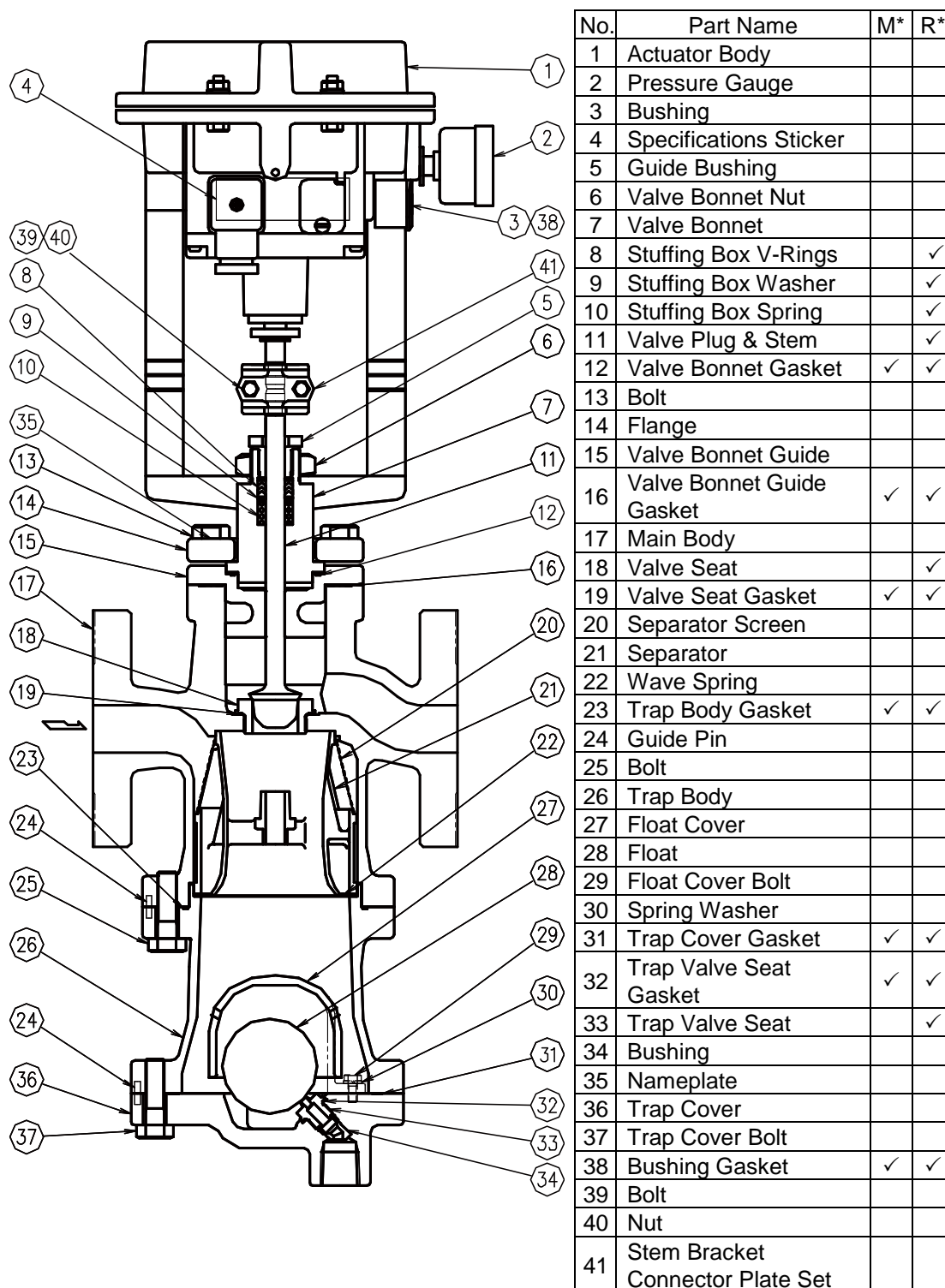

No.	Part Name	M*	R*
1	Actuator Body		
2	Pressure Gauge		
3	Bushing		
4	Specifications Sticker		
5	Guide Bushing		
6	Valve Bonnet Nut		
7	Valve Bonnet		
8	Stuffing Box V-Rings		✓
9	Stuffing Box Washer		✓
10	Stuffing Box Spring		✓
11	Valve Plug & Stem		✓
12	Valve Bonnet Gasket	✓	✓
13	Bolt		
14	Flange		
15	Valve Bonnet Guide		
16	Valve Bonnet Guide Gasket	✓	✓
17	Main Body		
18	Valve Seat		✓
19	Valve Seat Gasket	✓	✓
20	Separator Screen		
21	Separator		
22	Wave Spring		
23	Trap Body Gasket	✓	✓
24	Guide Pin		
25	Bolt		
26	Trap Body		
27	Float Cover		
28	Float		
29	Float Cover Bolt		
30	Spring Washer		
31	Trap Cover Gasket	✓	✓
32	Trap Valve Seat Gasket	✓	✓
33	Trap Valve Seat		✓
34	Bushing		
35	Nameplate		
36	Trap Cover		
37	Trap Cover Bolt		
38	Bushing Gasket	✓	✓
39	Bolt		
40	Nut		
41	Stem Bracket Connector Plate Set		

*Replacement parts are available only in the following kits:
M = Maintenance Kit
R = Repair Kit

Installation



Install properly and **DO NOT** use this product outside the recommended operating pressure, temperature and other specification ranges. Improper use may result in such hazards as damage to the product or malfunctions which may lead to serious accidents. Local regulations may restrict the use of this product to below the conditions quoted.



Use hoisting equipment for heavy objects (weighing approximately 20 kg (44 lb) or more). Failure to do so may result in back strain or other injury if the object should fall.



Take measures to prevent people from coming into direct contact with product outlets. Failure to do so may result in burns or other injury from the discharge of fluids.

Installation, inspection, maintenance, repairs, disassembly and adjustment and valve opening/closing should be carried out only by trained maintenance personnel.

Check to make sure that the piping where the product is to be installed is constructed properly. If the piping is not correctly constructed, the valve may not perform optimally.

1. Blowdown

Before installing the CV-COS unit, be sure to blow down all piping thoroughly. If this is not possible, perform a blowdown using the bypass valve. Blowdown is especially important for newly installed piping or after the system has been shut down for a long period of time.

2. Removing any Protective Caps and Seals

Before installation, be sure to remove all protective seals and caps. (Found in 3 locations, on the product inlet and outlets.)

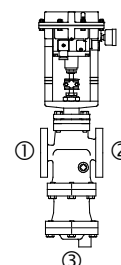

3. Installation Angle

Install the CV-COS so that the arrow mark on the body points horizontally in the direction of steam flow, and it should be installed horizontally in the piping with the actuator at the top. Allowable inclination is 10 degrees in the fore-aft direction and 15 degrees in the plane perpendicular to the steam flow line.

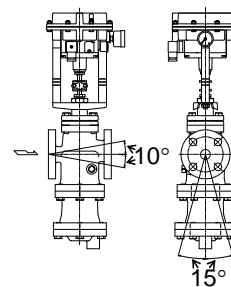

4. Piping Support

Install the CV-COS, paying attention to avoid excessive load, bending and vibration. Support the inlet and outlet pipes securely.

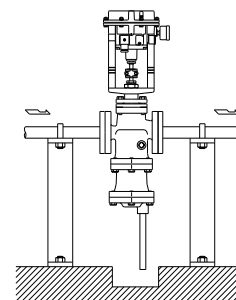

5. Maintenance Space

Leave sufficient space for maintenance, inspection and repair. (Units: mm)

100 mm \approx 4"
 110 mm \approx 4 $\frac{1}{2}$ "
 300 mm \approx 12"
 400 mm \approx 16"

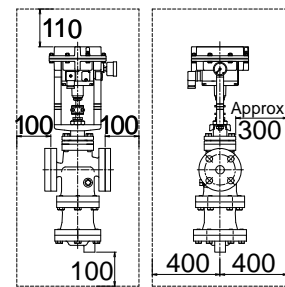

6. Trap Outlet Pipe

For ease of maintenance, installation of a union connection is recommended for the trap outlet pipe. Connect the outlet pipe to a condensate return line, or extend it to a trench. In the case of the latter, make sure the end of the pipe is above the waterline. (Dirt and water may be sucked up by the vacuum formed during trap closure and system shutdown.) If the end must be underwater, make sure the piping has a small hole, as shown in the drawing below.

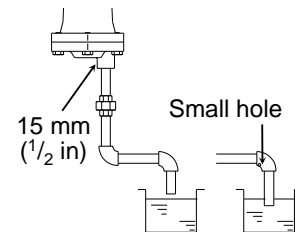

7. Accessories

Always install a shut-off valve, pressure gauge and bypass lines at both inlet and outlet. Ball valves, which will not retain condensate, are recommended for inlet and outlet shut-off valves. The bypass pipe should be at least 1/2 of the size of the inlet (primary side) pipe.

8. Installation Environment

Check the installation environment to make sure that the ambient temperature does not exceed the actuator ambient temperature limit and that no corrosive gasses are present.

9. Shut-off Valve Installation

Though the CV-COS adequately performs the function of a shut-off valve initially, extended use will result in a drop in its performance as an isolation valve. Be sure to install a separate shut-off or automatic valve if complete isolation is needed.

10. Safety Valve Installation

When installing a safety valve, be sure not to install it between the control valve and the shut-off valve

It must be installed near the equipment it is to protect, on the outlet side of the shut-off valve.

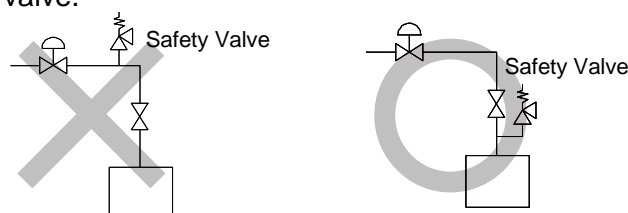

11. Avoid Foreign Matter and Water Hammer

Do not install in locations in the piping where foreign matter accumulates or where impact from water pressure (water hammer) occurs.

12. Piping Gaskets

Be careful that the piping gaskets do not protrude outside the inner bore of the flange.

The type of medium being used and the temperature must be taken into account in order to select a gasket of a suitable material.

13. Air Line Blowdown/Purge

Before connecting the air lines for the motive air that is to be piped to the actuator, blow out the air in the lines to purge any dirt, foreign matter, oil or water from inside of the piping.

14. Quality of Motive Air

Supply to the actuator only clean air that does not contain water, oil or foreign matter.

To prevent malfunction due to contamination of the air supply, installation of the optional air filter regulator (5 μ filter) and mist separator (0.3 μ filter) as a set is recommended.

If air quality results in operation failure, the entire actuator unit (including the integrated positioner) must be replaced.

If there is a problem in operation, determine the cause using the "Troubleshooting" section in this manual.

Electrical Wiring



Make sure the power supply is OFF before carrying out work on the wiring or inspections involving disassembly. If such work is carried out with the power on, there is a danger that equipment may malfunction or electric shock may occur, leading to injury or other accidents.



Make sure that wiring work requiring a special license is carried out only by qualified personnel. If carried out by unqualified personnel, overheating or short circuits leading to injury, fires, damage or other accidents may occur.

Connecting the Electrical Plug Connector

1. Loosen the screw (1) in the center section of the electrical wiring plug connector by using a screwdriver.
2. Pull the entire plug connector out of the actuator. Be careful not to lose the rubber gasket (5).
3. Insert a screwdriver into the notch (4) in the terminal plug (3) and remove the terminal plug (3) from the plug connector case (2).
4. Insert the input signal wiring through the wiring connection port (6) and connect the wiring to the 1(+), 2(-) and ground terminals at the symbols imprinted on the terminal plug (3), taking care not to reverse the polarity.
5. Reinsert the connected terminal plug (3) into the plug connector case (2). When inserting the terminal plug (3) into the plug connector case (2), the orientation of the wiring connection port may be altered by rotating the terminal plug (3) 90° or 180°.
6. Reinsert the plug connector into the actuator. Make sure to correctly align the male and female pins. Remember to reinsert the rubber gasket (5) between the plug connector and the actuator.
7. Retighten the screw (1) in the center section of the electrical wiring plug connector by using a screwdriver.

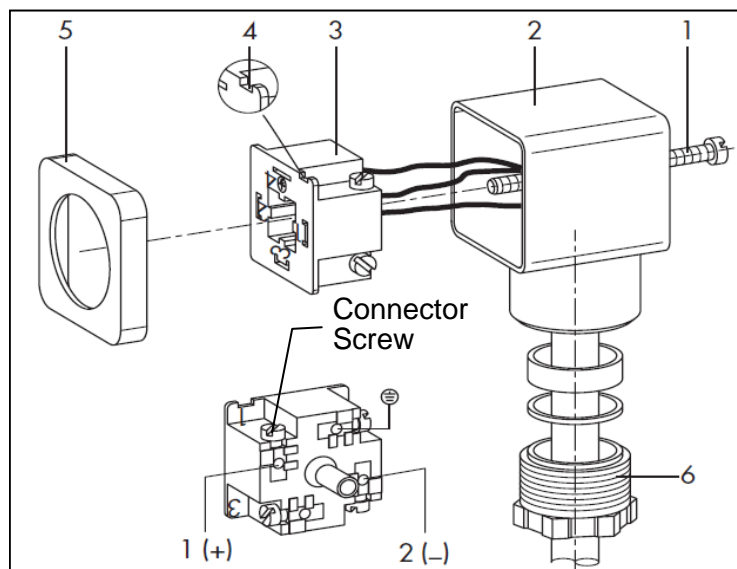

NOTE: Use shielded cable to avoid noise interference in the electrical wiring.

Operational Check

Before beginning steady operation, perform an operational check by following the steps outlined below:

1. Close the shut-off valves on the CV-COS inlets and outlets. Check operation without yet starting the flow of steam.
2. Check to make sure the designated air pressure is being supplied to the pneumatic positioner. (Air pressure: 0.38 MPaG (54 psig))
NOTE: -If the air supply pressure is incorrect, adjust it using an inlet air reducing valve.
-If an air reducing valve is attached, check the reading on its pressure gauge.
3. Turn on the power to the controller operation signal source, etc. (referred to hereinafter as the controller).
4. Set the operation signal output from the controller to the CV-COS to 0% (4 mA).
5. Check the CV-COS valve travel and the actuator air supply pressure.
Valve Travel: Fully closed (valve travel 0%)
Air Pressure: 0 MPaG (check the pressure gauge on the pneumatic positioner for the air pressure)
NOTE: If the air pressure is not 0 MPaG (0 psig), refer to the "Adjusting the Zero/ Span" section of this product Instruction Manual and adjust the zero.
6. Set the controller operation signal to 100% (20 mA).
7. Check the CV-COS valve travel and the actuator air supply pressure.
Valve Travel: Fully open (valve travel 100%)
Air Pressure: Approximately 0.38 MPaG (54 psig) (check the pressure gauge on the pneumatic positioner for the air pressure)
NOTE: -If the valve travel differs widely from 100%, refer to the "Adjusting the Zero/ Span" section of this product Instruction Manual and re-adjust the span and the zero.
-If the control valve does not move from the fully closed position, check to see if the wires for the controller and control valve have any breaks, a short-circuits, or have their polarity reversed (+ and – are reversed).
8. Set the controller operation signal to 50% (12 mA).
9. Make sure valve travel is smooth and without vibration.
NOTE: If the valve is vibrating vertically, it may be being caused by noise on the signal wiring. Check to see if there is a possible source of noise nearby.

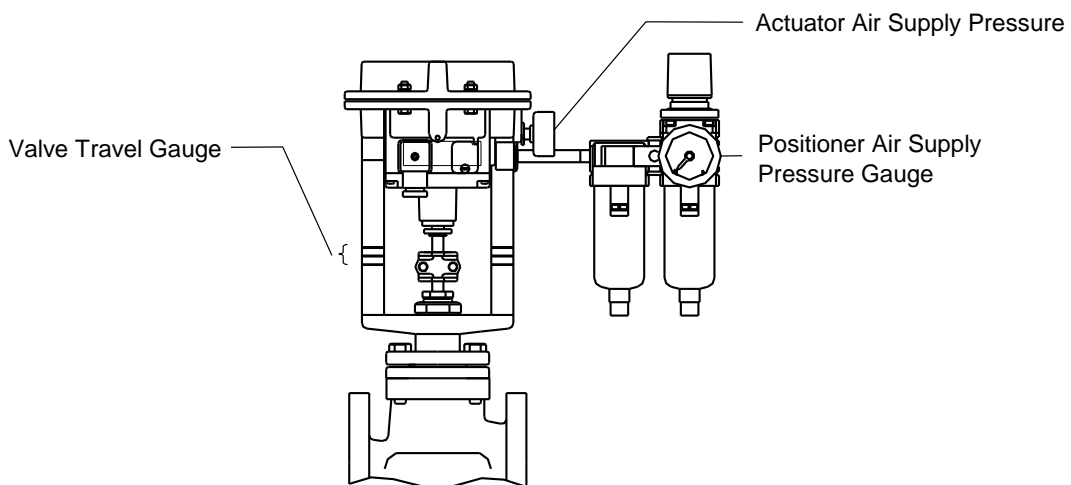

Adjusting the Zero/Span

1. After connecting the air piping, operate the air pressure reducing valve to maintain the positioner air supply pressure at 0.38 MPaG (54 psig) (reverse action).
2. Connect a current generator or a controller for input of an operation signal of 4 to 20 mA.
3. Loosen the cover plate screw and open the cover plate.
4. Pull out the jumper pin. (Be sure not to lose it.)
5. Set the operation signal output from the current generator or controller to 4 mA (0%).
6. Turn the zero adjustment dial slowly until the valve just begins to open (the actuator pressure gauge just begins to move). (The valve must NOT be open.)
NOTE: Turning counterclockwise causes the valve to begin to open earlier.
7. Change the operation signal to 4.1 mA (1%) and check to make sure the valve begins to open.
8. Change the operation signal to 4 mA (0%) and check to make sure the valve is completely closed (the actuator pressure gauge is completely at zero).
9. Change the operation signal to 20 mA (100%), and make sure that the stroke indicator reads in the vicinity of 100%.
If it does not, use a precision flat-head screwdriver to turn the span adjustment potentiometer until it is close to 100%.
NOTE: Turning clockwise increases the stroke (travel).
10. Each modification of the span results in a zero shift. Repeat the above correction procedure until both the zero and span are correct.
11. After completing the adjustment, insert the jumper pin securely into their previous position and close the cover.

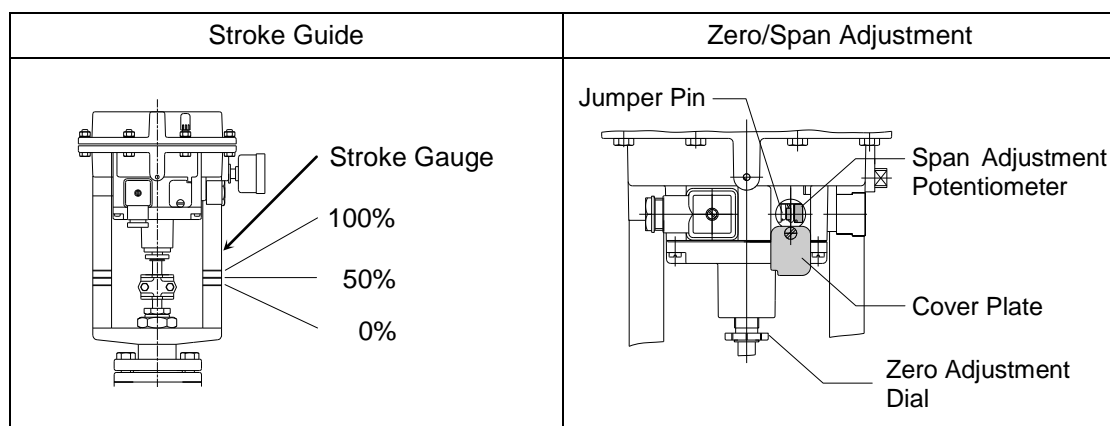

Maintenance



Take measures to prevent people from coming into direct contact with product outlets. Failure to do so may result in burns or other injury from the discharge of fluids.



When disassembling or removing the product, wait until the internal pressure equals atmospheric pressure and the surface of the product has cooled to room temperature. Disassembling or removing the product when it is hot or under pressure may lead to discharge of fluids, causing burns, other injuries or damage.



Be sure to use only the recommended components when repairing the product, and NEVER attempt to modify the product in any way. Failure to observe these precautions may result in damage to the product or burns or other injury due to malfunction or the discharge of fluids.

Operational Check

An inspection of the following items should be done on a daily basis to determine whether the product is operating properly or has failed. Periodically (at least biannually) the operation should also be checked.

In the event of failure (malfunction), also refer to the "Troubleshooting" section for remedies.

Inspection Item	Inspection Points	Remedy for Failure (Malfunction)
Leakage from valve (when the valve is closed)	Visual inspection or stethoscope inspection; is the outlet side pressure or temperature elevated, or is there the sound of the medium flowing?	Adjust the zero/span; if that does not solve the problem, replace with a new valve plug & stem and valve seat
Leakage from gland area	Visual inspection; is fluid leaking from the gap between the gland and the valve stem, or are there signs it has leaked previously?	Coat the gland and the valve stem with grease; if that does not solve the problem, replace with new V-rings
Air leakage from actuator	Visual inspection or stethoscope inspection; can the sound of a large amount of air leaking from the actuator area or the exhaust tap during stable actuator operation always be heard?	Replace with a new actuator unit
Leakage from the gaskets between any pressurized parts	Visual inspection; is fluid leaking from the gasket areas on pressurized parts?	Apply additional tightening (refer to recommended torque) or replace with new gaskets
Leakage from pressurized parts such as body and valve bonnet	Visual inspection; is fluid leaking from pressurized parts such as the body or valve bonnet?	Replace any pressurized parts at leak locations
Leakage from the trap area	Visual inspection or stethoscope inspection; is live steam being discharged from the trap outlet piping, or can the sound of a steam leak be heard?	Clean the sealing surface of the trap valve seat or replace the valve seat
Operating conditions	Visual inspection; does the actual valve travel differ from the designated operation signal value?	Readjust the air pressure reducing valve and positioner zero and span; if that does not solve the problem, refer to the "Troubleshooting" section

Disassembly/Reassembly



When disassembling or removing the product, wait until the internal pressure equals atmospheric pressure and the surface of the product has cooled to room temperature. Disassembling or removing the product when it is hot or under pressure may lead to discharge of fluids, causing burns, other injuries or damage.



Be sure to use only the recommended components when repairing the product, and NEVER attempt to modify the product in any way. Failure to observe these precautions may result in damage to the product or burns or other injury due to malfunction or the discharge of fluids.

Use the following procedures to remove components. Use the same procedures in reverse to reassemble. (Installation, inspection, maintenance, repairs, disassembly, adjustment and valve opening/closing should be carried out only by trained maintenance personnel.)

NOTE: Be sure to coat all threaded portions of the valve seat and bolts with anti-seize.

Perform the following procedure before beginning disassembly:

1. After connecting the air piping, operate the air pressure reducing valve to maintain the positioner air supply pressure at 0.38 MPaG (54 psig).
2. Connect a current generator or a controller for input of an operation signal of 4 to 20 mA.

Removing/Reattaching the Stem Bracket Plates

Part	During Disassembly	During Reassembly
—	Set the actuator air supply pressure to 0 MPaG (0 psig) to maintain the valve in the fully closed position.	Set the actuator air supply pressure to 0 MPaG (0 psig) to maintain the valve in the fully closed position. Check to make sure the valve stem and actuator stem are in firm contact with each other.
Bolts and Nuts	Remove with a socket wrench	Consult the table of tightening torques and tighten to the proper torque
Stem Bracket Plate	Take the bracket apart (separates into 2 plates)	After aligning the plates, tighten the nuts and bolts while making sure the gap between the plates is even on both sides

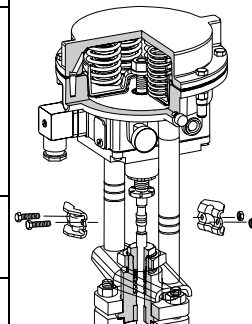

Be careful not to pinch your fingers between the valve stem and actuator stem!

Disassembling/Reassembling the Valve and Actuator Sections

Part	During Disassembly	During Reassembly
—	Set the operation signal input to 12 mA (50%) Make sure the gap between the valve stem and the actuator stem is open	Set the operation signal input to 12 mA (50%) Make sure the gap between the valve stem and the actuator stem is open
Valve Bonnet Nut	Remove with an open-end wrench	Consult the table of tightening torques and tighten to the proper torque

The actuator unit orientation can be changed.

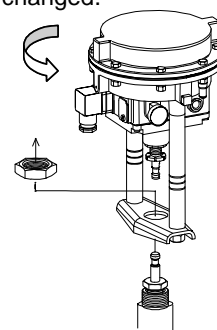

Be careful not to pinch your fingers between the valve stem and actuator stem!

Disassembling/Reassembling of the Body Section

Part	During Disassembly	During Reassembly
Guide Bushing	Loosen slightly with a socket wrench to make the following procedure easier	Consult the table of tightening torques and tighten to the proper torque
Bolts for flange	Remove with a socket wrench	<u>Tighten the bolts evenly, while checking to make sure that there is no catching or biting when the valve plug is seated in the valve seat;</u> after tightening to the rated torque, check to make sure that the valve plug & stem moves up and down smoothly; make sure to tighten it evenly
Flange Valve Bonnet	Pull up and off, being careful not to damage the valve plug & stem or valve seat	Reattach, being careful not to damage the valve plug & stem or valve seat Insert the valve bonnet into the gasket housing securely and without tilting
Valve Bonnet Gasket	Remove the gasket and clean sealing surfaces	Replace with a new gasket; <u>do not coat with anti-seize</u>
Valve Bonnet Guide	Pull up and off, taking care not to damage the valve plug & stem or valve seat The difference between the inner diameter of the body and the outer diameter of the valve bonnet guide is very small, so make sure that it does not tilt and get caught when pulling the valve bonnet guide up and off	Reattach, being careful not to damage the valve plug & stem or valve seat The difference between the inner diameter of the body and the outer diameter of the valve bonnet guide is very small, so make sure that it does not tilt and get caught when inserting the valve bonnet guide
Valve Bonnet Guide Gasket	Remove the gasket and clean sealing surfaces	Replace with a new gasket if warped or damaged
Valve Plug & Stem	Pull up and out, being careful not to damage the plug & stem	Reattach, being careful not to damage the plug & stem
Valve Seat	Remove with a socket wrench	Consult the table of tightening torques and tighten to the proper torque
Valve Seat Gasket	Remove the gasket and clean sealing surfaces	Replace with a new gasket if warped or damaged

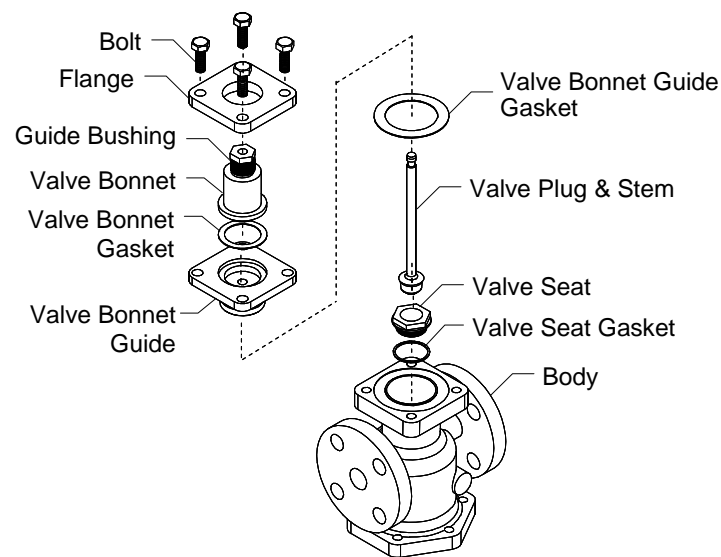

Removing/Reattaching the Separator and its Components

Part	During Disassembly	During Reassembly
Bolts for the Main and Trap Body	Remove with a socket wrench When lifting the main body, be careful not to let the separator fall out	Consult the table of tightening torques and tighten to the proper torque
Separator Screen	Remove the separator screen	Being careful not to bend it, insert it securely onto the slanted part of the separator
Separator	Remove the separator	Insert it into the groove in the main body
Wave Spring	Remove the wave spring	Insert it into the groove in the trap body

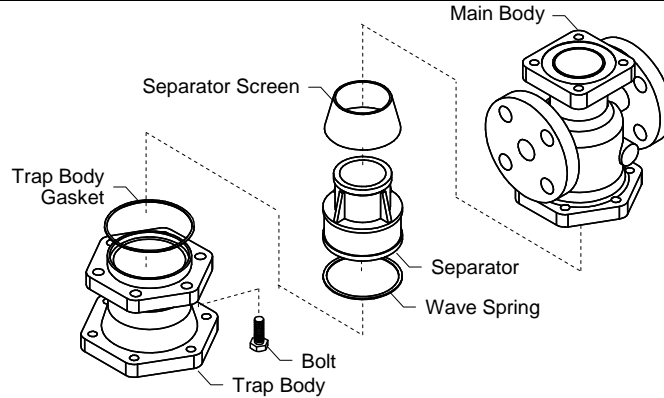

Removing/Reattaching the Trap and its Components

Part	During Disassembly	During Reassembly
Bolts for Trap Cover	Remove with a socket wrench	Consult the table of tightening torques and tighten to the proper torque
Float Cover Bolt & Spring Washers		
Float Cover	Pull up and off	Replace
Float	Take care not to scratch or misshape the surface of the float	Take care not to scratch or misshape the surface of the float
Trap Valve Seat	Remove with a socket wrench	Consult the table of tightening torques and tighten to the proper torque
Trap Valve Seat Gasket	Remove the gasket and clean sealing surfaces	Replace with a new gasket if warped or damaged
Trap Cover Gasket	Remove the gasket and clean sealing surfaces	Replace with a new gasket if warped or damaged

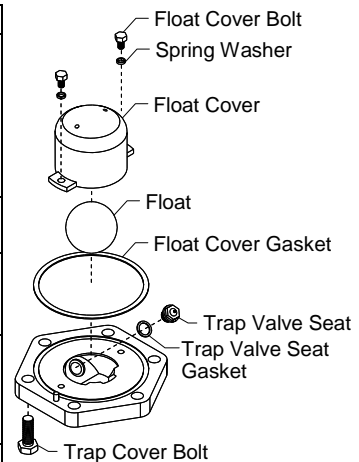

Disassembling/Reassembling the Gland and its Components

In the procedure below, first partially loosen the guide bushing and then remove the valve plug & stem before removing the other parts. (The procedure is most easily performed if the bushing is loosened while it is attached to the valve body.)

Part	During Disassembly	During Reassembly
Guide Bushing	Remove with a socket wrench	Consult the table of tightening torques and tighten to the proper torque
Stuffing Box V-Rings	Pull up and out	Make sure to reassemble the V-rings in the proper orientation; coat the groove with heat-resistant silicon grease; <u>reattach the V-rings with their grooves facing downward</u>
Stuffing Box Washer	Pull up and out	Reinsert
Stuffing Box Spring		

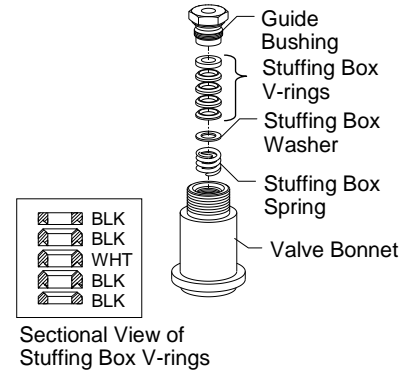

Parts Inspection

When parts have been removed, use the following table to inspect the parts and replace any that are found to be defective.

Inspection Item
Gasket(s): Check for warping and damage (Graphite gaskets MUST be replaced if disassembled)
Stuffing Box V-rings: Check for warping or damage
Valve Plug & Stem, Valve Seat: Check for damage or scratches
Separator screen: Check for clogging and corrosion
Trap Valve Seat: Check for scratches, dents, etc.
Float: Check for scratches, dents, etc.

Table of Tightening Torques

Part	15 mm (1/2 in)		20 mm (3/4 in)		25 mm (1 in)		40 mm (1 1/2 in)		50 mm (2 in)	
	Torque N·m (lbf·ft)	Dist. Across Flats mm (in)	Torque N·m (lbf·ft)	Dist. Across Flats mm (in)	Torque N·m (lbf·ft)	Dist. Across Flats mm (in)	Torque N·m (lbf·ft)	Dist. Across Flats mm (in)	Torque N·m (lbf·ft)	Dist. Across Flats mm (in)
Bolts and Nuts for Stem Bracket Plates	7 (5.1)	8 (5/16)	7 (5.1)	8 (5/16)	7 (5.1)	8 (5/16)	7 (5.1)	8 (5/16)	7 (5.1)	8 (5/16)
Guide Bushing (Valve Bonnet Section)	120 (88)	24 (15/16)	120 (88)	24 (15/16)	120 (88)	24 (15/16)	120 (88)	24 (15/16)	120 (88)	24 (15/16)
Bolts for Flange	40 (29)	17 (21/32)	40 (29)	17 (21/32)	40 (29)	17 (21/32)	40 (29)	17 (21/32)	50 (37)	19 (3/4)
Valve Seat	100 (73)	30 (13/16)	100 (73)	30 (13/16)	125 (92)	36 (1 13/32)	250 (185)	50 (1 31/32)	300 (220)	60 (2 3/8)
Bolts for Main Body and Trap Body	60 (44)	17 (21/32)	60 (44)	17 (21/32)	60 (44)	17 (21/32)	60 (44)	17 (21/32)	70 (51)	19 (3/4)
Bolts for Float Cover	7 (5.1)	8 (5/16)	7 (5.1)	8 (5/16)	10 (7)	10 (3/8)	10 (7)	10 (3/8)	20 (15)	13 (1/2)
Trap Valve Seat	10 (7)	11 (7/16)	10 (7)	11 (7/16)	15 (11)	13 (1 1/2)	15 (11)	13 (1 1/2)	40 (29)	17 (2 1/32)
Bolts for Trap Cover	60 (44)	17 (21/32)	60 (44)	17 (21/32)	60 (44)	17 (21/32)	60 (44)	17 (21/32)	70 (51)	19 (3/4)
Nut for Actuator	150 (72)	36 (1 13/32)	150 (72)	36 (1 13/32)	150 (72)	36 (1 13/32)	150 (72)	36 (1 13/32)	150 (72)	36 (1 13/32)

(1 N·m ≈ 10 kg·cm)

Troubleshooting



When disassembling or removing the product, wait until the internal pressure equals atmospheric pressure and the surface of the product has cooled to room temperature. Disassembling or removing the product when it is hot or under pressure may lead to discharge of fluids, causing burns, other injuries or damage.

When the product fails to operate properly, use the following table to locate the cause and remedy.

Problem	Cause	Diagnosis	Remedy (Countermeasure)
Valve Leakage	The pressure of the air supply to the positioner is too high	Check the pressure of the air supply to the positioner and confirm product specifications	Adjust the pressure of the air supply for the positioner to match the pressure in the product specifications
	The positioner's zero point is miscalibrated	Check the actuator air supply pressure (on the positioner's pressure gauge) when the operation signal is at 4 mA	If the pressure on the pressure gauge is elevated (not 0 MpaG (0 psig)), adjust the positioner's zero point
	The inlet pressure for the valve is too high	Check the inlet pressure for the valve	Operate at an inlet pressure of 1.0 MPaG (150 psig) or less
	The valve plug and valve seat are off-center	Move the valve plug & stem up and down and check to see if it catches	Reassemble the valve bonnet section correctly
	There is a problem with the sealing surfaces of the valve plug and valve seat	Check the valve plug and valve seat	Replace with a new valve plug & stem and valve seat
The valve does not travel beyond a certain point	The bellowsphragm in the actuator is broken	Check to see if a large amount of air is leaking from the exhaust tap	Replace with a new positioner/actuator unit [Check to make sure that the valve is not operating (traveling) too often and that the ambient temperature is not too high]
	The positioner's internal parts are broken (the diaphragm is cracked, etc.)	Check to see if any unusual noise is coming from the positioner	Replace with a new positioner/actuator unit [Check to make sure that the valve is not operating (traveling) too often and that the ambient temperature is not too high]
	There is insufficient air supply pressure to the positioner	Check the pressure of the air supply to the positioner and refer to product specifications	Adjust the supply air pressure for the positioner (Confirm product specifications)
	Malfunction of the signal system	Check to make sure the controller is emitting a 4 to 20 mA signal and that the wires are not disconnected, etc.	Inspect the controller and repair the signal wiring if necessary

Continued on next page

Problem	Cause	Diagnosis	Remedy (Countermeasure)
No movement at all	Air is not being supplied to the positioner	Make sure that the compressor is operating as it should; make sure that the regulator connected to the positioner inlet is set	Initiate the supply of the designated air supply pressure to the positioner (Confirm product specifications)
	The input signal wiring is incorrectly connected	Check to make sure the wiring is connected to the correct terminals and that the + and - polarity is not reversed	Correct the connections
	The input signal is not being input	Check that 4 to 20 mA is being input by the positioner connection terminals	Repair the operation signal origin or repair the signal wiring
	Positioner's internal parts are broken (the diaphragm is cracked, etc.)	Check to see if any unusual noise is coming from the positioner	Replace with a new positioner/actuator unit [Check to make sure that the valve is not operating (traveling) too often and that the ambient temperature is not too high]
	There is water or oil inside the positioner	Check to see if there is water or oil entrained in the supply air; check to see if the humidity at the control valve piping location is too high	Replace with a new positioner/actuator unit and improve the quality of the air supply
Valve opens and closes too slowly	There is water or oil inside the positioner	Check to see if there is water or oil entrained in the air supply	Replace with a new positioner/actuator unit and improve the quality of the air supply
	The filter regulator is clogged	Check the filter	Clean the filter or replace with a new filter
Valve travel is unstable	The setting of the controller is faulty	Check the set value based on the controller's PID parameters	Adjust the controller's setting values
Steam is blowing	There is a build-up of dirt on the trap valve seat or on the float	Check the trap valve seat and the float	Clean or replace with a new trap valve seat or float
	The body is installed tilted	Check the installation conditions	Correct the installation
	The float is deformed	Check the float	Replace with a new float (Inspect for water hammer or freezing)
	There is vibration in the piping	Check the piping conditions	Remove the source of the vibration or reinforce the piping supports
No condensate is discharged	The primary pressure exceeds the trap valve seat maximum working pressure	Check the primary pressure	Change to a suitable pressure
	Water is inside the float	Check the float	Replace with a new float (Investigate to see if the flow medium contains corrosive substances)
	Output piping is clogged	Check the outlet piping	Clean or modify the piping
	The trap valve seat is clogged	Check the trap valve seat	Clean or replace with a new trap valve seat

Product Warranty

1. Warranty Period
One year following product delivery.
2. Warranty Coverage
TLV CO., LTD. warrants this product to the original purchaser to be free from defective materials and workmanship. Under this warranty, the product will be repaired or replaced at our option, without charge for parts or labor.
3. This product warranty will not apply to cosmetic defects, nor to any product whose exterior has been damaged or defaced; nor does it apply in the following cases:
 - 1) Malfunctions due to improper installation, use, handling, etc., by other than TLV CO., LTD. authorized service representatives.
 - 2) Malfunctions due to dirt, scale, rust, etc.
 - 3) Malfunctions due to improper disassembly and reassembly, or inadequate inspection and maintenance by other than TLV CO., LTD. authorized service representatives.
 - 4) Malfunctions due to disasters or forces of nature.
 - 5) Accidents or malfunctions due to any other cause beyond the control of TLV CO., LTD.
4. Under no circumstances will TLV CO., LTD. be liable for consequential economic loss damage or consequential damage to property.

* * * * *

For Service or Technical Assistance:

Contact your TLV representative or your regional TLV office.

Manufacturer

TLV CO., LTD.

881 Nagasuna, Noguchi
Kakogawa, Hyogo 675-8511, JAPAN
Tel: 81-(0)79-427-1800

Options



Install properly and **DO NOT** use this product outside the recommended operating pressure, temperature and other specification ranges. Improper use may result in such hazards as damage to the product or malfunctions which may lead to serious accidents. Local regulations may restrict the use of this product to below the conditions quoted.



Take measures to prevent people from coming into direct contact with product outlets. Failure to do so may result in burns or other injury from the discharge of fluids.

The following options are available to meet individual specification requirements, so please verify your particular product.

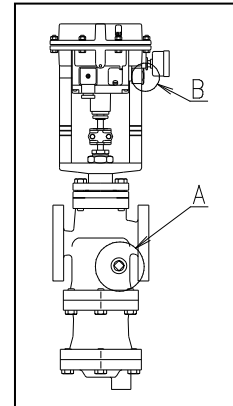

Body Options (Section A) (Standard: Flangeless)

No Plug

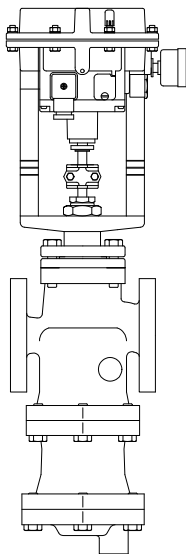

With Plug

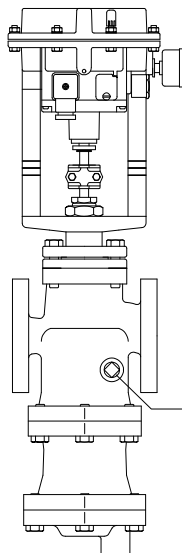

Rc(PT)^{3/8}
BSPT^{3/8}
NPT^{3/8}

Torque		Dist. Across Flats	
N·m	(lbf·ft)	mm	(in)
30	(22)	12	(1/2)

(1 N·m ≈ 10 kg·cm)

NOTE: Wrap sealing tape 3 – 3.5 times around the threaded portions.

Applications for Use

Where there are large amounts of dirt or scale, or for applications such as heating in which the equipment is shut down for long periods of time, be sure to install a blow/purge valve.

1. Remove the plug (optional) from the main body and install the blow/purge valve.
2. Open the blow/purge valve and blow any residual dirt and scale off of the screen.
3. Periodically activate the blow/purge valve to keep the system free of dirt and scale.

Actuator Unit Option (Section B)

With Filter Regulator
(Manual Condensate Discharge)

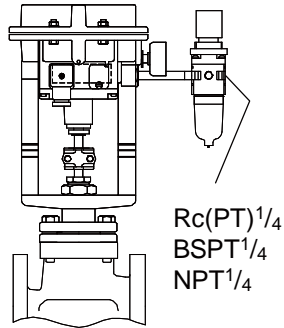

Rc(PT)^{1/4}
BSPT^{1/4}
NPT^{1/4}

Integrated Filter: 5 µm

With Mist Separator + Filter Regulator
(Manual Condensate Discharge)

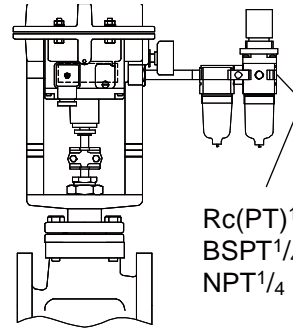

Rc(PT)^{1/4}
BSPT^{1/4}
NPT^{1/4}

Integrated Filter: 0.3 µm + 5 µm

With Filter Regulator
(Automatic Condensate Discharge)

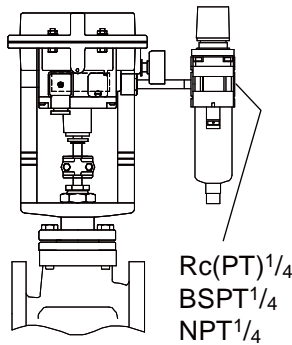

Rc(PT)^{1/4}
BSPT^{1/4}
NPT^{1/4}

Integrated Filter: 5 µm

With Mist Separator + Filter Regulator
(Automatic Condensate Discharge)

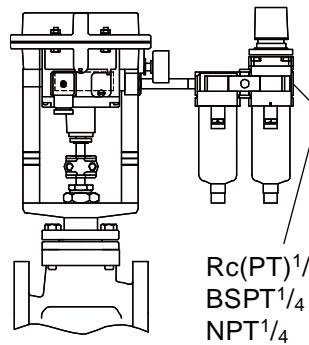

Rc(PT)^{1/4}
BSPT^{1/4}
NPT^{1/4}

Integrated Filter: 0.3 µm + 5 µm