

# ERB Series

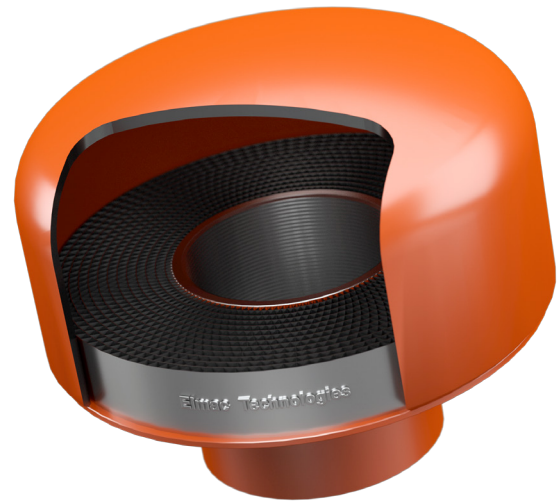

**RE-Flow™ End-of-line Deflagration Flame Arresters** Protecting People, Property and our Planet.

Elmac Technologies® ERB Series of End-of-line Deflagration Flame Arresters are designed to prevent atmospheric deflagrations from entering into a gas or vapour piping system, or a storage tank when installed at the end of a vent pipe.



## Principle of Operation

Elmac ERB Flame Arresters (patent pending) incorporate Elmac's E-Flow™ enhanced crimped ribbon technology in the flame arrester element. The channel dimensions of the element are optimised for deflagration protection; whilst ensuring minimal maintenance requirements and maximising flow performance.

In the event of explosion, the combustion products are cooled at the element surface by heat dissipation, which prevents continuation of the combustion process through the flame arrester and into the protected vent line. The ERB Series Flame Arresters' unique operating mode allows downward venting (RE-Flow™) and self-draining of the flame arrester element. This ensures minimal plugging or clogging of the element under normal operating conditions.

## Explosion Groups

Elmac ERB Series are ATEX certified for gases in Explosion Groups IIA1, IIA, IIB1, IIB2 & IIB3.

## Elmac Expertise

Elmac has been manufacturing protection equipment since 1948 and brings enhanced levels of flame and explosion protection to a diverse range of applications.

Elmac offers considerable technical leadership and, using test facilities along with Computational Fluid Dynamics (CFD) capabilities, employs research teams renowned for developing solutions for the most challenging of industrial applications.

## Features and Benefits

- Simple, compact, robust and light
- Up to 5 x lighter than standard flanged arresters
- Self-draining element prevents rain, dirt or other foreign matter entering the piping system
- Easy visual in-situ inspection of the element
- E-Flow™ element provides optimum flow performance
- Quick and easy to install and maintain
- Threaded and flanged connection options available
- Minimum plugging or clogging of the element with minimal maintenance

### General Arrangements:

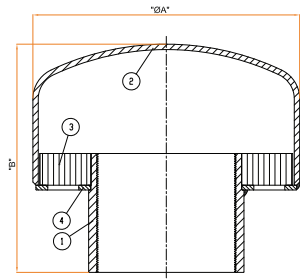

Standard Material Specifications		
Ref	Description	Material
1	Female Socket	Stainless Steel
2	End Cap	Stainless Steel
3	Crimped Ribbon Element	Stainless Steel
4	Element Ring	Stainless Steel

Dimensions			
DN(mm)	ØA (mm)	B (mm)	Approx Wt (kg)
10	89	69	0.7
15	89	79	0.7
20	89	82	0.7
25	89	77	0.7
32	141	107	1.8
40	141	107	1.9
50	141	116	1.9
65	168	138	2.9
80	168	144	3.0

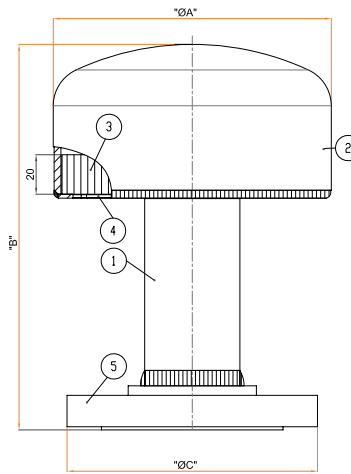

Standard Material Specifications		
Ref	Description	Material
1	Pipe	Stainless Steel
2	End Cap	Stainless Steel
3	Crimped Ribbon Element	Stainless Steel
4	Element Ring	Stainless Steel
5	Connection Flange	Stainless Steel

Dimensions				
DN(mm)	ØA (mm)	B (mm)	ØC (mm)	Approx Wt (kg)
15	89	165	95	1.2
20	89	165	105	1.4
25	89	165	115	1.7
32	141	195	140	3.1
40	141	195	150	3.5
50	141	195	165	4.4
65	168	215	185	6.7
80	168	215	200	7.4

### Variations

Feature	Standard Fitting	Options*
Arrester Materials	Stainless Steel	On Request
Element Material	Stainless Steel	On Request
Connections	BSP/NPT Female/Flanged	Adapters for Other Connection Types

\*Depending on flame arrester size.

### Operating conditions

The operating temperature for ERB Flame Arresters is -20°C to +60°C.

### ERB Flow Curves

Pressure drop performance varies according to a particular flame arrester configuration. Further information is available on request from Elmac.

### Standards Compliance

Elmac Technologies® Flame Arresters have been type-tested to EN ISO 16852 and certified according to ATEX Directive 2014/34/EU.

Actual device performance is verified in the Elmac Technologies® state-of-the-art in-house test facility.



### Customer Support

Tel: +44 (0) 1352 717 555

Email: sales@elmactech.com

Fax: +44 (0) 1352 717 642

Coast Road, Greenfield, Flintshire, CH8 9DP United Kingdom

### RE-Flow™

The diagram below demonstrates the out-breathing of gases and/or vapours through the ERB housing and element to vent to atmosphere.

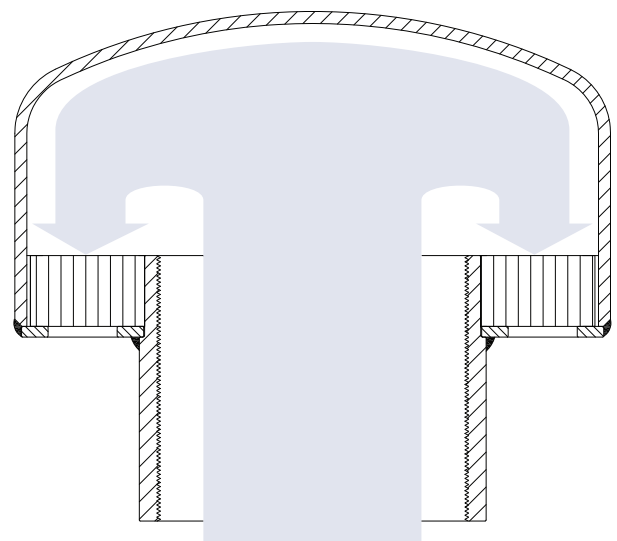

All specifications are correct at time of print, are for guidance purposes only and subject to change without prior notice.



Protecting People, Property and our Planet.