

high resolution linear actuator for the installation on valves

- Fast stroking speed
- Small dead band
- Smooth start and slow down
- Seperate terminal box
- Robust aluminium housing
- Gear box of metal
- Multiple setting possibilitys
- Limit switch control by force



Technical data

Driving force	2,0 kN / 5,0 kN	
Power connections	24 V AC/DC 100 - 240 V 50/60Hz	
Ambient temperature	Standard:	-10°C up to +60°C
	Low temperature version:	-40°C up to +60°C
Storage Temperature	Standard:	-30°C up to +80°C (+60°C with Fail-Safe protection)
	Low temperature version:	-40°C up to +80°C (+60°C with Fail-Safe protection)
Mounting position	choice horizontal or vertical actuator only	
Protection class (EN 60529)	IP 67	
Max. power consumption	40 Watt	
Dead band	±0,2% at min. 6mm stroke	
Repeat accuracy	±0,1% at min. 6mm stroke	
Stroking speed	2,0 kN-version:	0,75 s/mm up to 250 s/mm (standard 1,5 s/mm)
	5,0 kN-version:	2 s/mm up to 250 s/mm (standard 4 s/mm)
Stroking speed of the Fail-Safe protection	2,0 kN-version:	0,75 s/mm up to 4 s/mm
	5,0 kN-version:	2 s/mm up to 4 s/mm
Set point range	adjustable 0(4) - 20 mA, 0(2) - 10 V optional binary input signal (24V DC)	
Feedback	adjustable 0(4) - 20 mA, 0(2) - 10 V	
cycles (Fail-Safe)	500.000	
life-time (Fail-Safe)	10 years	
duty cycle	100%	
Self Monitoring	monitoring of the driving power, set point, actuator temperature, temprature of the electronic etc.	
Diagnostic function	storage of motor and total service life, temperature- and way classes	
Valve adaptation	automatic stroke adjustment to suit valve limits	
additional inputs	binary input	
additonal outputs	2 alarm outputs	

Options

2 additional stroke limit switches	free adjustable volt free contacts (open/close)
Fail safe protection (in preperation)	Mounted in own body at actuator Safety position freely selectable
Communication software	with communication link, for parametrization and diagnosis of the actuator
Bluetoothmodul BT-1	Wireless connection to DeviceConfig configuration software (upgrade option)

Ordering number-system

2	0	3	0	/	0	1	0	A							

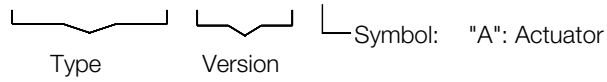

1 - 5 : Please quote all 5 sections.
6 - 16: Quote only if required.

1.	Model	2.	Supply voltage	3.	-	4.	Mounting kit	5.	Fail save position
0	2 kN-linear actuator with position electronics	0	100-240V 50/60Hz	-		0	without mounting kit	-	without fail save position
1	5 kN-linear actuator with position electronics	1	24V AC/DC			1	with columns (L=217,5), coupling complete with position indicator and additional regulation nut M8	1	Spindel moved out in case of power failure
								2	Spindel moved in in case of power failure
6.	Communication	7.	Control signal	8.	Limit switch	9.	Stroking speed	10.	Adjustments
1	Standard (without)	-	standard, for actuators with position electronics 4-20 mA or 2-10V	-	Without	-	Standard (1,5 s/mm= 0,67 mm/s)	-	Standard (dead band adjusted to ±0,2%)
B	Additional blue-tooth modul	3	0-20 mA or 0-10V	2	Two stroke dependent limit switches	1	0,75 s/mm = 1,33 mm/s		
		5	inverted function, 4-20 mA or 2-10V, 20mA(10V) closed, 4mA(2V) open			2	1 s/mm = 1 mm/s		
		A	control actuator with binary control (24V 3-point control)			3	2 s/mm = 0,5 mm/s		
						4	4 s/mm = 0,25 mm/s		
						9	20s/mm = 0,05mm/s		

ordering example: 2030/010A-1-0-B-2

High resolution motor actuator, version 1.0, actuator 2kN, without mounting kit, without fail safe position, with bluetooth module, set point range standard: 4-20 mA / 2-10 V, two limit switches

dimensions and weight without mounting kit

2kN-actuator

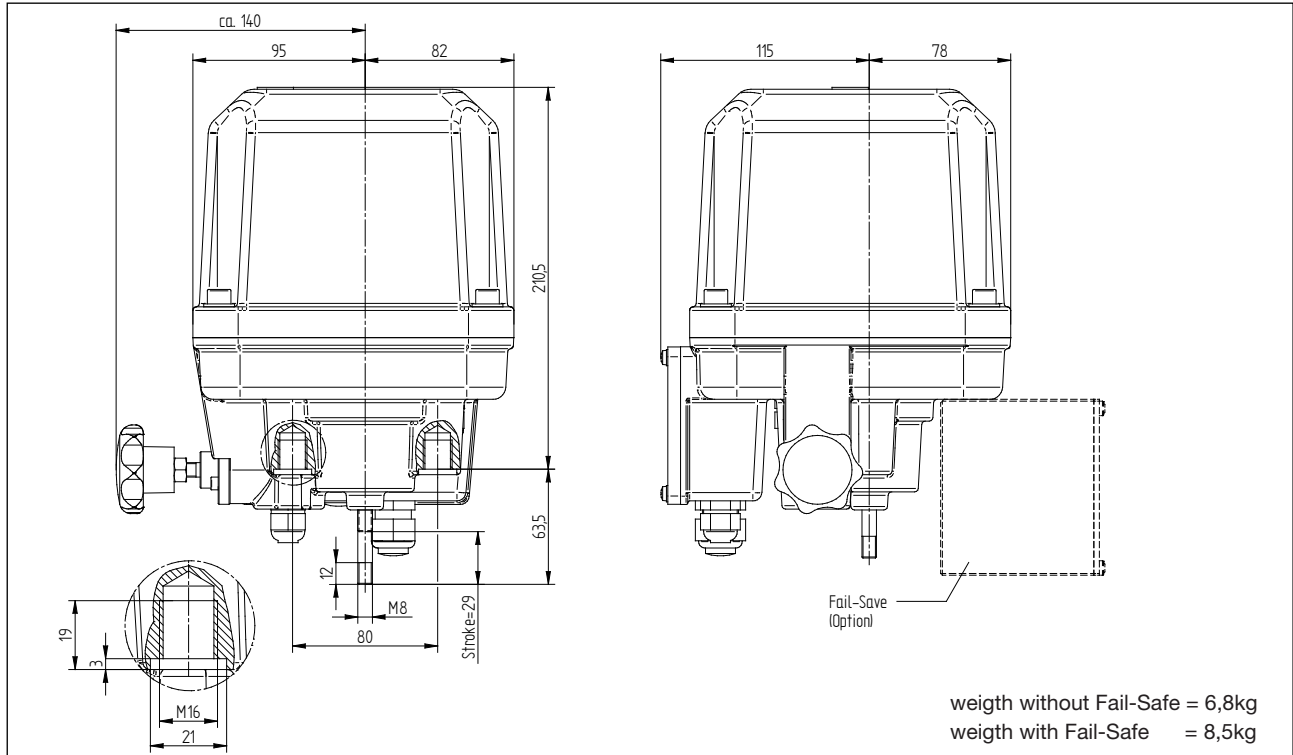

dimensions in mm

5kN-actuator

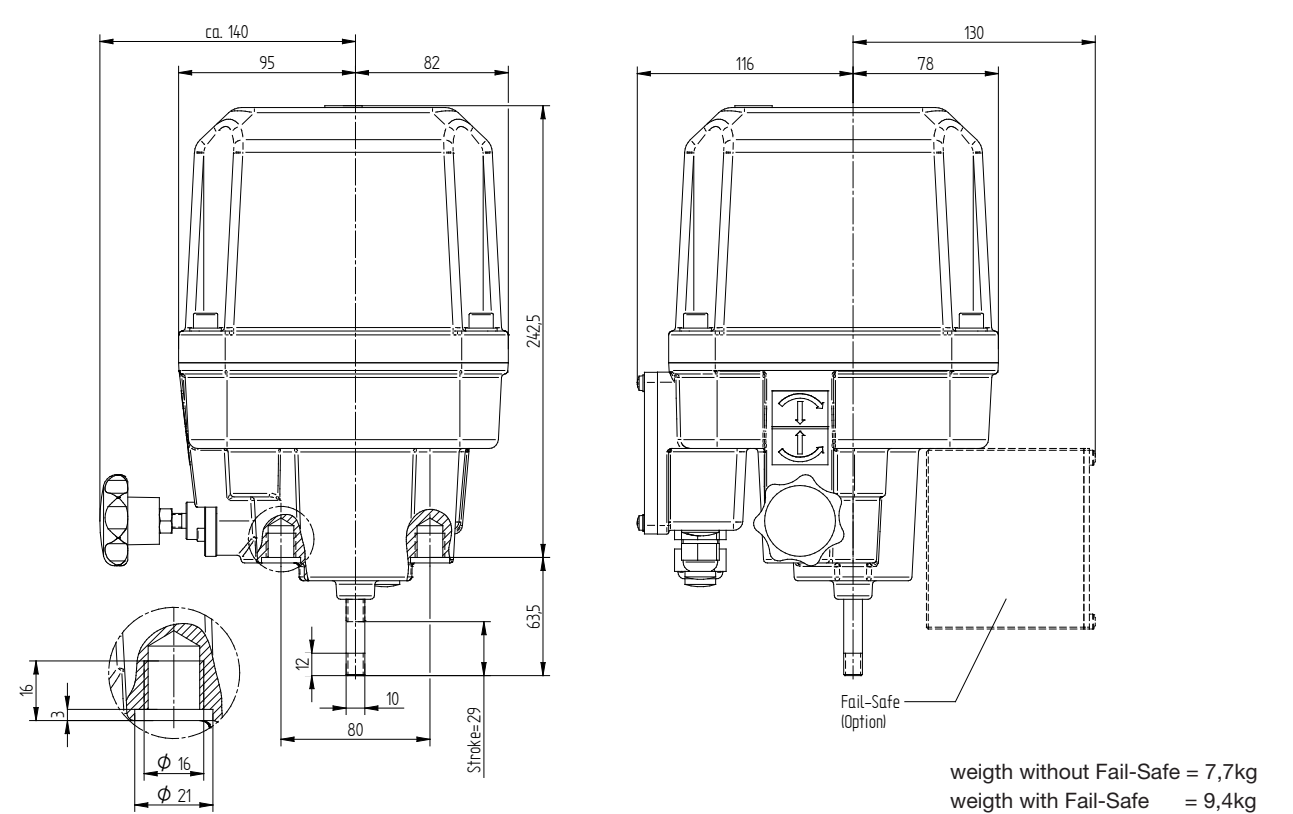

dimensions in mm

dimensions and weight with mounting kit

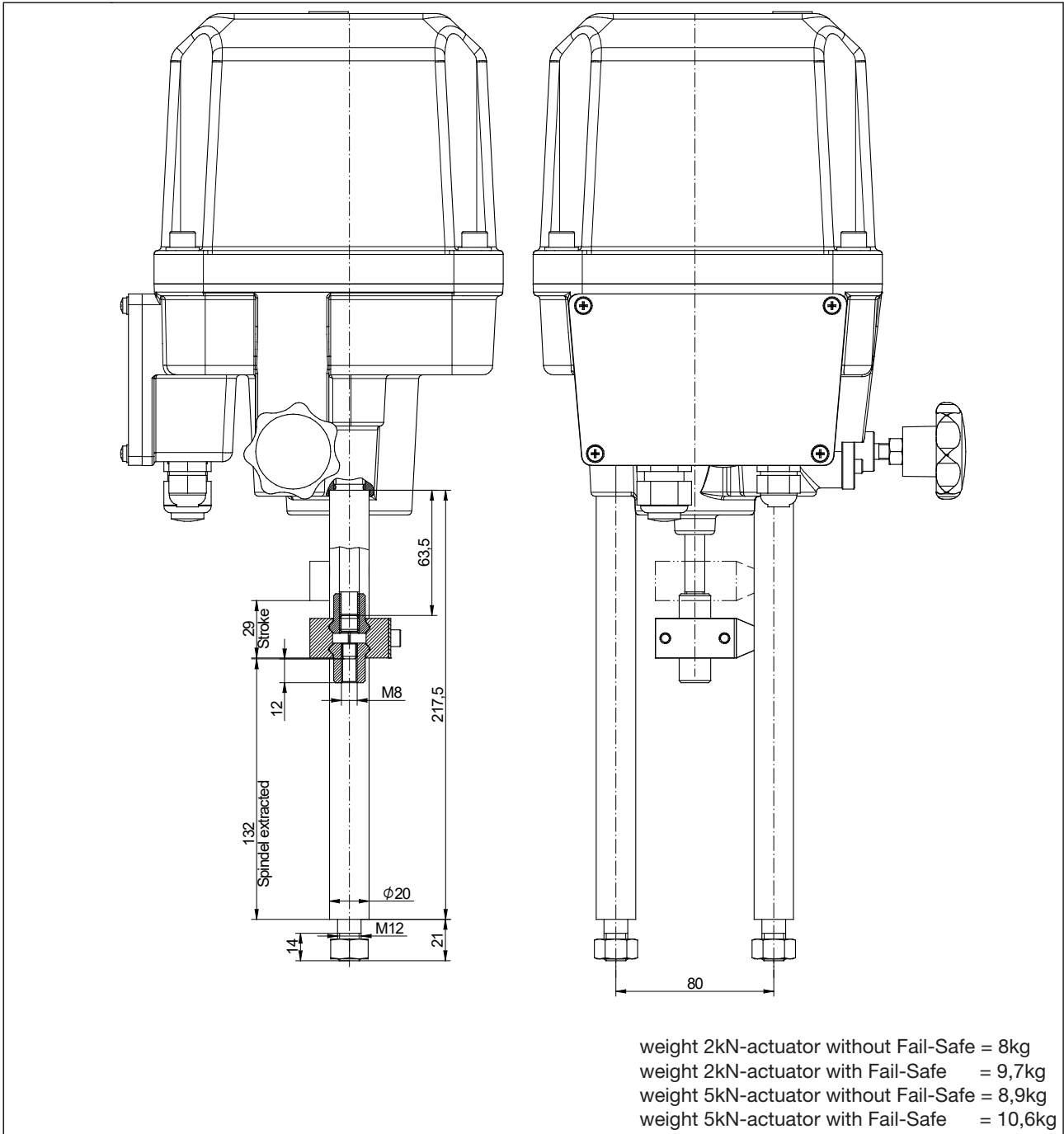

dimensions in mm