

Manual for 90-Degree Failsafe-Actuators - ABFSQT-HA

1 Introduction / Comments

90-degree Actusafe actuators are designed to operate on corresponding fittings and provide fail-safe functionality where it is needed.

They are applicable for any gate valve requiring a 90-degree movement to operate. (flap valves, ball valves, valves in general, etc.)

In case of voltage failure or in case of deliberate triggering of the Failsafe function, the mechanical built-in energy storage of our 90-degree Actusafe actuators is used to move the gate valve into the Failsafe-position specified by the customer.

BEWARE! Actuator contains disc springs under tension!

Inappropriate dismantling may cause heavy damage to device and health!

If maintenance operations require the dismantling of the actuator, we advise you to contact SCHIEBEL Antriebstechnik GesmbH for detailed instructions concerning special tools and proper tension release!

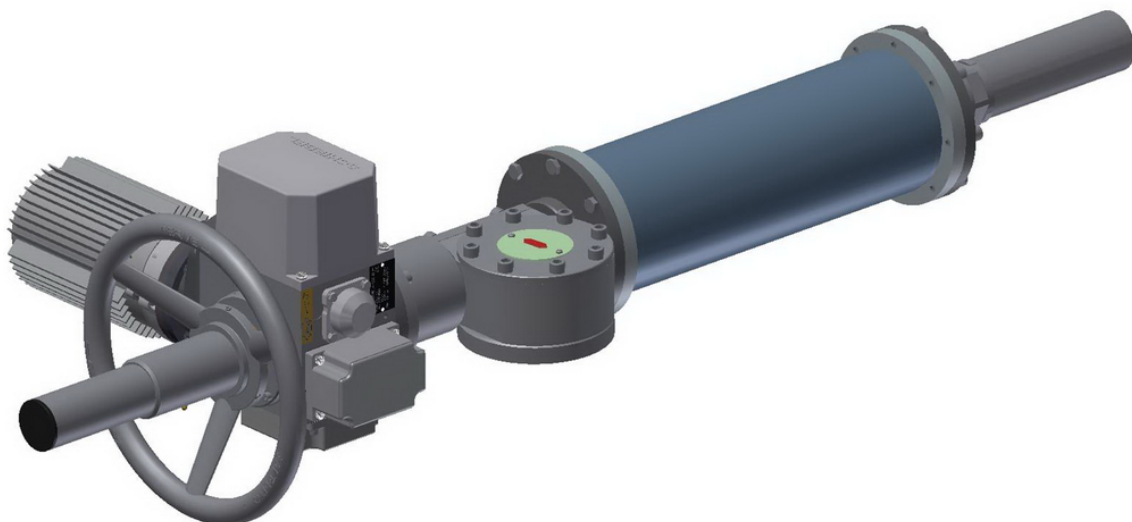

Figure 1

2 Functional Introduction to the AB FSQT HA Failsafe Actuator

In normal shifting operation, a three-phase motor (1) equipped with an electromagnetic brake with positive operation (positive action brake) (2), powers the 3-gear, non-self-locking worm gear (3) of the actuator via an intermediate spur gear (4). During shifting, the operating current brake is open (de-energized = no braking). The drive shaft of the worm gearing is positive locked and torsion-proof keyed to the nut of a spherical spindle drive (5), which has axial roller bearings for the absorption of the resulting forces. The spherical spindle drive transforms the rotational movement of the gear into an axial (linear) movement (thrust). On the one hand, the linear movement is transferred to the valve shaft (9) via a 90°-gearing (rack and pinion gear) (6) and on the other, to the energy storage mechanism (packet of discsprings) (7). There are no disengaging or engaging parts between the three-phase motor, the valve shaft and the energy store, with the result that there is a permanent power flow.

During the opening movement of the valve, the three-phase motor must supply the shifting power required for the valve shaft, while also charging or preloading the energy storage for fail safe switching. A discharge from the energy storage is prevented by the holding power of the brake. A discharge is only possible if the motor is running free and can be driven or pulled (reversed power flow as in the case of an electric motor opening thrust, actuated by the unloading of spring tension in the energy storage). The positive action brake holds the

valve in the position despite the energy stored. In the case of fail safe switching, the operating current supply of the motor brake is interrupted. The tension on the accumulator disc springs eases and moves the thrust spindle (also simultaneously turning the nut of the spherical spindle drive, which in turn pulls the 3-gear worm gearing and the spur gears of the three-phase motor) until a mechanic end position buffer (8) is reached, which mechanically limits, or ends the movement. This mechanic end position buffer is combined with the adjustable mechanic end stop(9), which allows to preset the failsafe position.

This drive type has an additional hand wheel (10) for a manual override emergency. About this handwheel is possible when de-energized to move the valve against the Failsaferichtung, the Failsafe thereby overridden! When released, the handwheel position is fixed automatically.

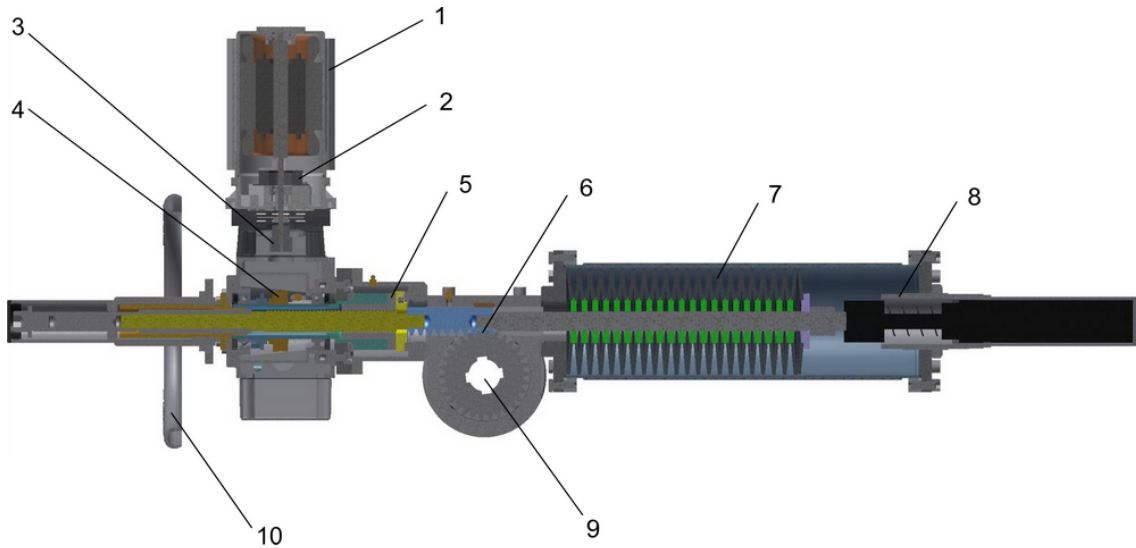

Figure 2: Functional description

This Failsafe-Actuator can be built in a version for fail-safe opening (ccw rotation) or failsafe closing (cw rotation) the valve. It is even possible to change the fail-safe direction subsequently, by some minor installation works (separate manual available). However, we recommend the installation to be carried out in the factory.

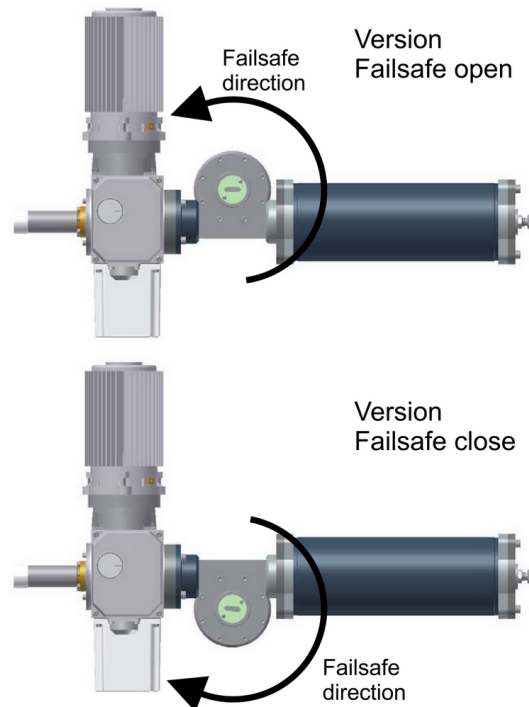

Figure 3: Rotating direction

3 General

3.1 Safety Instructions

During electrical operation certain parts inevitably carry lethal voltages. Work on the electrical system or equipment must only be carried out by a skilled electrician himself or by specially instructed personnel under the control and supervision of such an electrician and in accordance with the applicable electrical engineering rules.



When working in potentially explosive areas, observe the European Standards EN 60079-14 "Electrical Installations in Hazardous Areas" and EN 60079-17 "Inspection and Maintenance of Electrical Installations in Hazardous Areas".



For work carried out in hazardous areas, special regulations (European Standard EN 60079-17) must be observed.

For work carried out in hazardous areas, special regulations (European Standard EN 60079-17) must be observed..



3.2 Serial Number

Refer to manual for actuators.

3.3 Degrees of protection provided by enclosures

Refer to manual for actuators.

3.4 Installation Position

Refer to manual for actuators and see section 6.1.3, page 8.

3.5 Rotating Direction

The standard rotating direction is:

- Clockwise rotation = Actuator moving contrary to failsafe direction
- Counter-clockwise rotation = Actuator moving in failsafe direction



Which rotating direction causes opening or closing the valve depends on:

- Failsafe direction of the actuator
- Closing direction of the valve



All data in this manual refers to the standard rotating direction.

3.6 Protective Gear

Refer to manual for actuators.

3.7 Ambient Temperature

Refer to manual for actuators.

3.8 State of Actuators upon Delivery

Refer to manual for actuators.

3.9 Indications (Tags)

Refer to manual for actuators.

4 Transportation and Storage

CAUTION: The actuator must only be lifted at the eyebolts and by soft belts on spring-unit - see Figure 4

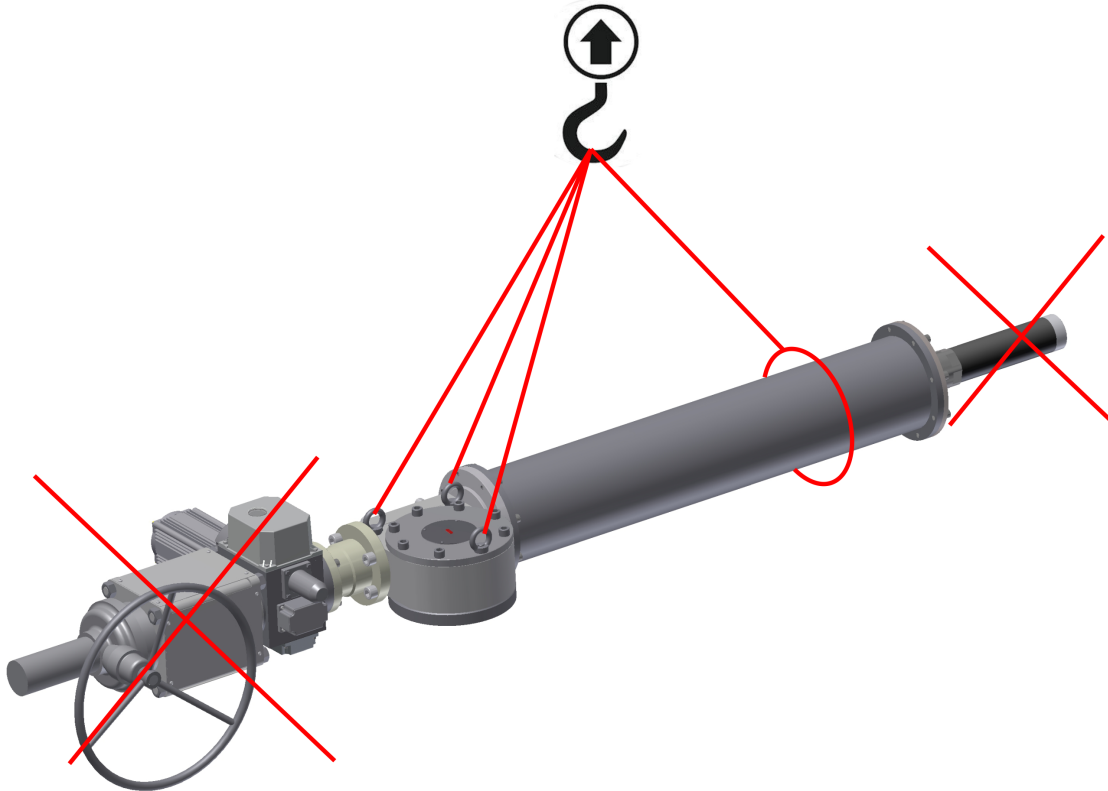

Figure 4

For more information see the manual for actuators.

5 Installation Instructions

Any installation work on the actuator may only be carried out by specially trained personnel.

5.1 Mechanical Connection

Make sure

- that the fitting flanges and the actuator flanges match!
- that the bore hole matches the shaft!
- that the mounting shaft engages properly into the drive hole!
- **Make sure the valve is in the same state as the actuator:**
 - For a failsafe open actuator the valve has to be open.
 - For a failsafe close actuator the valve has to be closed.
- Clean all exposed parts which have been coated with anti-corrosive.
- Thoroughly clean the bolting surfaces of the fittings.



- Grease the shaft of the valve.
- Place the actuator on the fittings.
- Ensure centered position and full contact surface of the flanges.
- Fix Actuator using suitable screws:

Minimum strength category 8.8 or A2-70.

Ensure sufficient thread engagement (min. (1xD)).

Screws that are too long can queue up at the thread root which is a risk that the actuator is moved radially in respect to the armature. This can result in shearing of the bolts.

Beware: unsuitable bolts may cause the actuator to fall!



- Tighten the fastening screws crosswise with the correct torque.

Screw Thread	Torque [Nm] for Screws with Strength Category	
	8.8	A2-70 / A4-70
M6	11	8
M8	25	18
M10	51	36
M12	87	61
M16	214	150
M20	431	294
M30	1489	564

5.2 Electrical Connection

Refer to manual for actuators.

6 Start Up

It is assumed that the actuator has been correctly assembled and electrically connected. (refer to section 5, page 4)

CAUTION: Remove silica gel from the indicator lid.

6.1 Manual Operation

This actuator design has the possibility of manual operation.

The handwheel is possible to move the valve from the failsafe while to fix in this position. This is the fail-safe function automatically disabled!



CAUTION: The manual mode can be used only in the energized state of the actuator! Before using the manual mode, you must ensure that the power supply of the operating current brake is not activated. Otherwise, the actuator may be damaged!



CAUTION! During manual operation must be excluded on the system side of motor start!



6.1.1 Manual operation up to AB40FSQT...

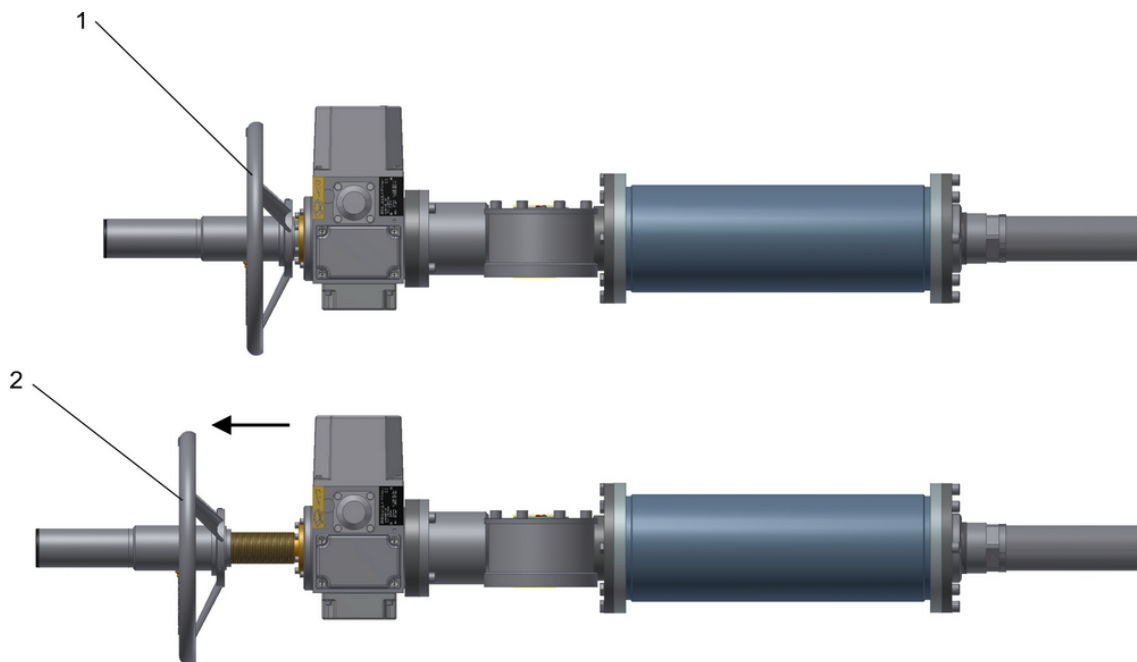

Figure 5: 1... Handwheel in position (standing at the drive housing on), 2... Handwheel in position manual mode (away from the drive housing)

Use the manual mode:

- brake power supply
- motor starting system side
- handwheel with a slight jerk by turning (counterclockwise) from the Position reached.
- left turn the handwheel causes adjustment of the valve against the Failsaferichtung
- The position is fixed automatically and can only be changed by turning the handwheel.
- To exit the manual mode and the drive re-release for automatic operation the hand wheel must be rotated by turning towards failsafe until it again reached at the housing. There has to be fixed by a little jerk again.
- The brake power supply can be restored
- The drive can be enabled for motorized operation



6.1.2 Manual operation larger than AB40FSQT...

From size AB40FSQT the manual mode is via an additional gearbox.

The manual operation is only intended to drive the actuator from the "failsafe position" into the "Not failsafe position". If the actuator is not in the failsafe position, it must be driven electrically or by disconnecting the power supply to the failsafe position before using the manual operation!



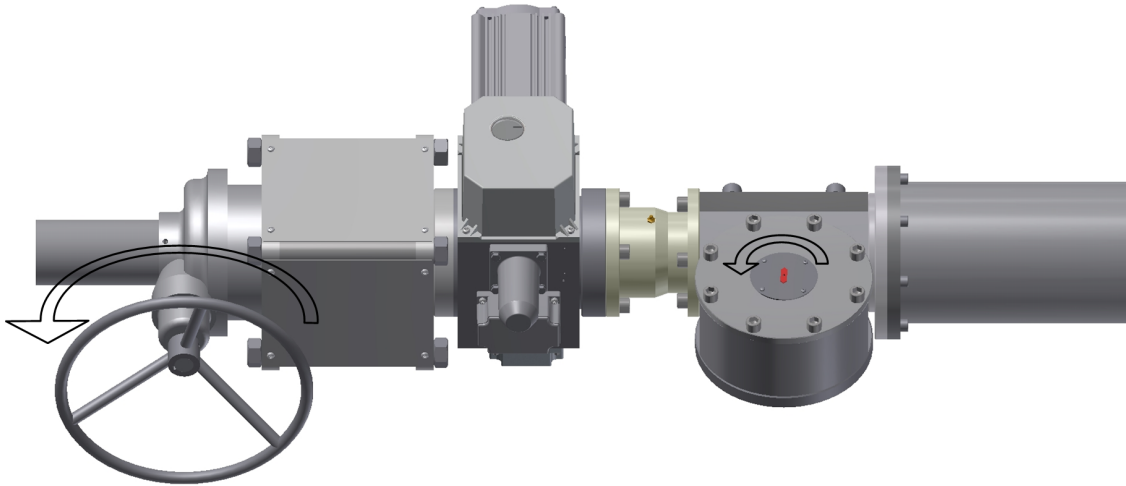



Figure 6

Use the manual mode:

- counterclockwise rotation on the handwheel causes movement of the valve against the failsafe direction
- After a few turns at the handwheel, a switch is triggered, the reports of the control manual mode, and automatically inhibits the electrical operation.
The display shows the message "Manual Override" can be read.
- The position is fixed automatically and can only be changed by turning the handwheel.
- Attention: To exit the manual operation and enable the actuator again for the automatic mode the handwheel must be turned clockwise toward the failsafe position until clear resistance can be felt. And is to be fixed by a little jerk again. 
- The control unit gives the engine operating free again, the message "Manual Override" disappears.
- **Note: If the actuator is not in the failsafe position and you start to turn the handwheel, the drive will start running by spring force in the close position. In this case, interrupt the manual operation immediately and wait until the actuator comes to a standstill! Otherwise, serious damage to the actuator and injury are the result!** 

6.1.3 Hydraulic hand lever

Assembling position

The hydraulic hand lever only works in specific positions of installation. These positions have to be considered during the mounting of the actuator to the valve.

valid positions of installation:

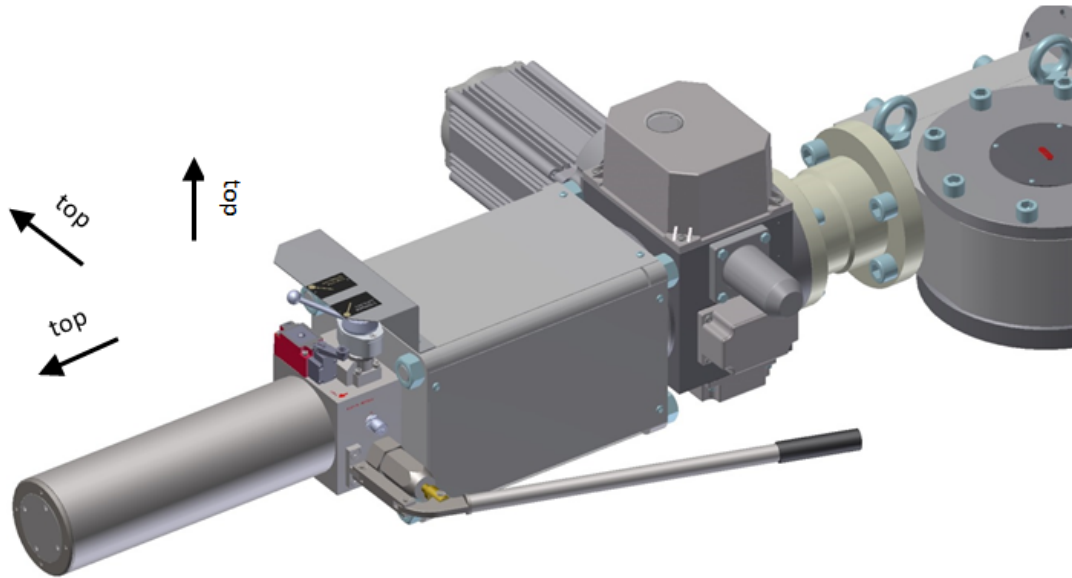

Figure 7

Hydraulic bleeding

Caution: After assembling the hydraulic component have to be bled, otherwise the sealing of the pump could be destroyed!



Caution: The Hydraulic bleeding have to be executed before the first use and in pressureless position!

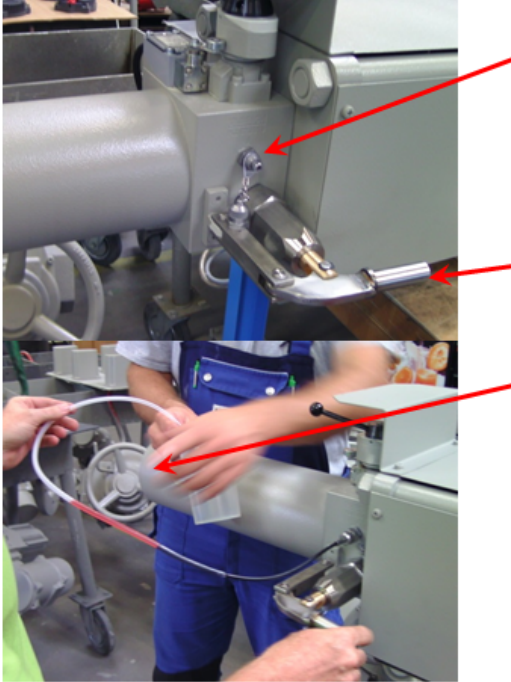

1. twist off the Minimesse closing cap
2. screw the vent line on the Minimesse engagement
3. swivel the switch lever to „MANUELL“ Position
4. start to pump
5. look at the oil in the vent line
6. there must not rise air bubbles in the vent line
7. twist off the vent line
8. screw the closing cap back to the Minimesse engagement

Figure 8: Hydraulic bleeding manual

Usage of the manual mode:

The manual mode is only designed for bringing the the actuator from the „Failsafe position“ in the „not Failsafe position“. Is the Actuator in the „ not Failsafe position“, the position have to be changed to the „Failsafe position“ by electric movement or cutting the power supply, to use the manual mode.



- To except uncontrolled movement after ending the manual mode, the control unit have to be set in the „OFF“-Mode.
- Swivel the switch lever to the „MANUELL“ Position until he snap into place. The display of the control unit switch to „manual mode“ and the electrical movement is not possible anymore.



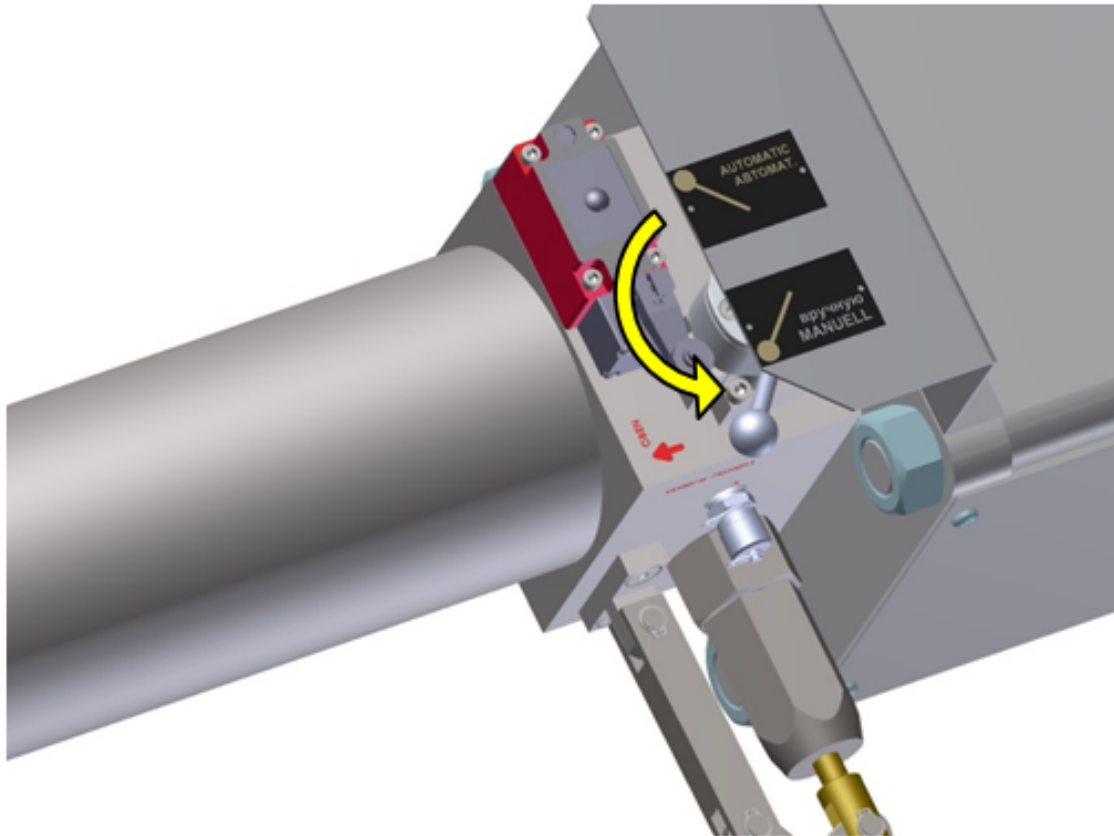

Figure 9

- Through pumping on the hydraulic pump the desired position could be set. Please note: If there are high forces needed to pump, the actuator could be blocked. In this case the problem which blocks the actuator should be solved to avoid damage.
- Finalize the manual mode: check, that the control unit is set in the „OFF“-Mode. Swivel the switch lever back in the „AUTOMATIC“-Position.

CAUTION: The actuator will be move in the „Failsafe“-Position. This could be stopped by moving back the switch lever. When the actuator reached the „Failsafe“-Endposition, the switch lever must be set in the „AUTOMATIC“-Position. Now the electrical operations are available.



6.2 Monitoring the Rotating Direction

The actuator has to be in the Failsafe-position.

Apply the electrical command "move contrary failsafe direction" to the actuator for a short period of time.

Make sure: The drive shaft has to be rotating contrary to the failsafe direction (away from Failsafe-end-position).

In case of incorrect rotating direction:

- With three-phase power-supply, interchange L1 and L2.
- With one-phase power-supply, interchange R and L.



Beware:

The travel and torque switches do not operate if rotating direction is incorrect. The result is the destruction of actuator and/or fittings!



6.3 Setting the Mechanical End Stop

A 90-degree Actusafe actuator comes with one adjustable mechanical endstop. It is located on the end of the housing of the spring arrangement.

Depending on the size of the actuator it may be combined with a hydraulic attenuator.

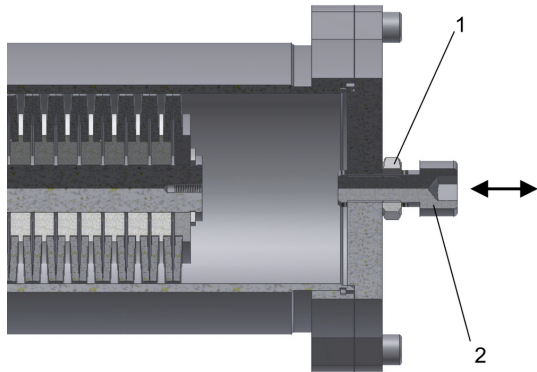

Figure 10: AB5FSQT05, AB5FSQT10, AB5FSQT20, AB5FSQT30
 (1... Check Nut, 2... End Stop)

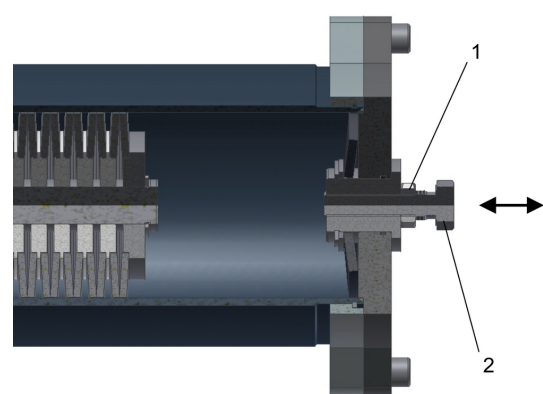

Figure 11: AB8FSQT50
 (1... Check Nut, 2... End Stop)

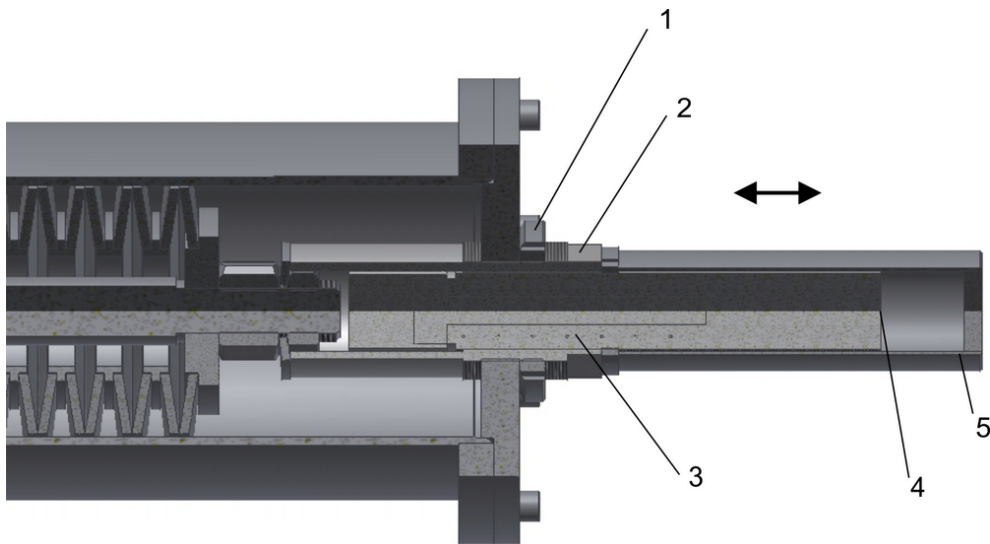

Figure 12: AB8FSQT80, AB8FSQT100, AB8FSQT200, AB18FSQT450, AB40FSQT600, AB40FSQT900
 (1... Check Nut, 2... End Stop(hexagonal AF70mm), 3... Hydraulic Attenuator, 4... Attenuator Adjustment Screw, 5... Cover)

To change the end stop, firstly release the check nut.

To achieve a longer stroke, screw the end stop out of the top flange.

Note: Upon delivery, the end stop is set to maximum stroke. Screwing the end stop out of the top flange any further does not have any effect on the length of the stroke, but renders the end stop ineffective. It is imperative to avoid this!



Check:

- Run the actuator against the stop, while in Failsafe-mode.
- Despite the check nut being loosened, it has to be impossible to move the end stop into the top flange any further.

Beware: If you intend to change the end stop position to shorten the stroke, make sure that the actuator is not in the Failsafe-position! It is necessary to move the actuator away from the end position by 10 percent prior to changing the adjustment!



After removing the check nut the end stop has to be screwed into the top flange and the adjustment of the end stop has to be checked through triggering a Failsafe-stroke.

Beware: Make sure that the mechanical end stop is not reached during regular operation on the fitting. After changing the adjustment of the mechanical end stop the adjustment of the limit switch has to be checked and may have to be readjusted.



When all adjustments were made, fasten the check nut once again!

6.4 Setting the Hydraulic Attenuator (only for AB8FSQT80-900)

Using a hydraulic attenuator allows for the adjustment of speeds during Failsafe-operation within certain limits. Upon delivery, the attenuator has been pre-adjusted. We advise you **not** to change this adjustment. If the attenuator is too weak, this may lead to force peaks upon contact with the end stop. If the attenuator is too strong, this may cause failure during the electrical operation of the actuator. However if changes are made, we advise you to carry them out step by step in combination with repeated test runs.



Procedure:

- Remove attenuator cover.
- On the front end of the attenuator, you will find a scale disc and an adjustment screw.
- Changing the adjustment to lower numbers causes weaker attenuation and higher speed and vice versa.
- Readjust the screw only by the value of one-half and then make a test run.
- After readjustment, replace the cover over the front end of the attenuator. During the readjustment procedure, take special care not to change the position of the attenuator relative to the actuator body!

6.5 Setting the End Positions

Refer to manual for actuators.

7 Maintenance

Any maintenance work may only be carried out while the disc spring arrangement is free from tension. To meet this requirement, the actuator has to be in the Failsafe-position!

(According to the ÖVE E5 standard, it has to be impossible to power on the device during maintenance.) The actuators are ready to use after commissioning has taken place. Upon delivery, our actuators are filled with grease (Upon request, oil is also possible).



Regular Maintenance Inspections:

- Listen for increased noise. Run actuator at least every three months.
- Checking on the Failsafe-function (Run-time and uniformity of the run). Increased run-times can be due to higher torque requirements after long periods of non-operation.

BEWARE! Actuator contains disc springs under tension!

Inappropriate dismantling may cause heavy damage to device and health!

If maintenance operations require the dismantling of the actuator, we advise you to

contact SCHIEBEL Antriebstechnik GesmbH for detailed instructions concerning special tools and



proper tension release!

As there is no specific restriction on the installation position (see Section 3.4, page 3), there is no oil gauge and no oil drain plug in the main casing.

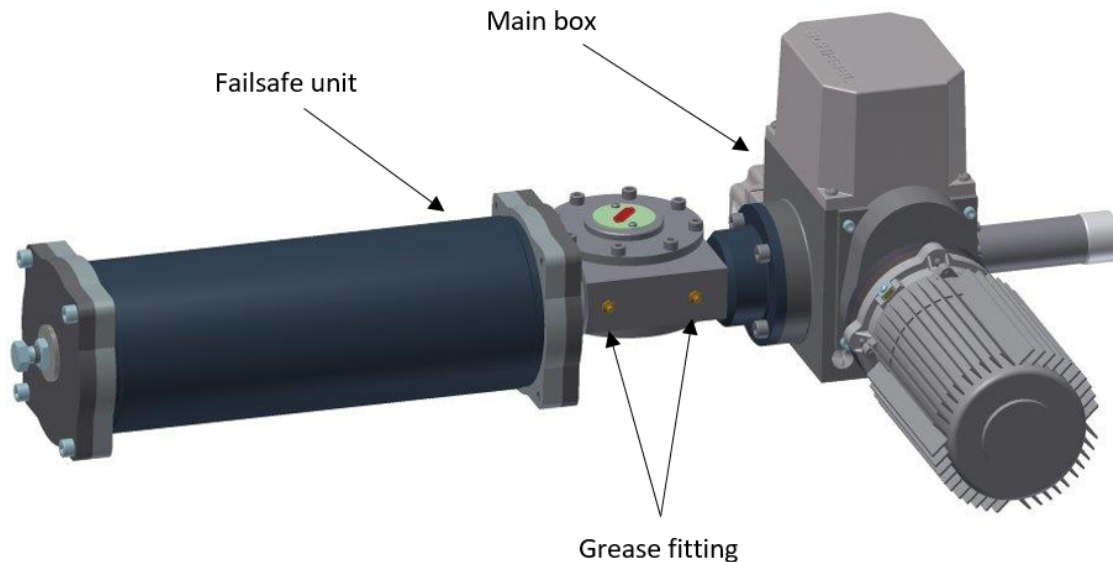

Figure 13: AB-FSQT-Grease-location

Depending on operational demand

- change grease (oil)-Main box,
- relubricate the Failsafe unit at the Grease fittings
- renew seals,
- check on all roller bearings and worm-wheel gear and replace them if necessary,

at every 10 000 to 20 000 hours of operation (around every 5 years - refer to section 9.2, page 14).
See the Table of Lubricants (Section 9, page 14) for the types of oil and grease to be used.

After the maintaining work the actuator have to pass through the whole lifting repeatedly. If there occur some problems it is necessary to replace the Grease fittings, hence surplus grease can pass out which could block the movement of the actuator.

Check the cable glands at regular intervals (annually) for tightness of the cables and retighten if necessary.

If the visual inspection (eg. dust or water penetration) indicates that the effectiveness of the Sealing elements of the cable entry has suffered damage or aging, such elements have to be replaced preferably by using the original spare parts from the manufacturer of the equipment or through cable entries of comparable quality as well as the same ex- or IP protection class.

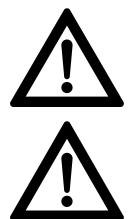

8 Replacement Parts

Refer to manual for actuators.

9 Recommended Lubricants (for all manufacturers)

9.1 Main Casing

Refer to manual for actuators.

9.2 Basic Lubricant Service Intervall

Refer to manual for actuators.

10 Lubricant Requirements

Refer to manual for actuators.

11 Training

Refer to manual for actuators.